

Application Issues for Spray-Applied Liquid UV Coatings

By David Hagood

Introduction

UV coatings offer many benefits to the user when compared to conventional solvent-based or water-based materials. Some of the more substantial benefits include faster process times, less work in process, less energy usage, less space needed for processing parts, potential reduction in volatile organic compounds (VOCs), lower capital costs for new systems and lower operating costs.

Until recently, most UV applications consisted of either flat or simple part configurations due to the ease of curing these types of products. Developments in UV coatings, UV-lamp technology and cure methodology have opened up the UV coat and cure market to more complex part profiles. This article will focus on the application issues for three-dimensional (3-D) coating spray processes.

UV-Coating Cost

One of the biggest misconceptions about finishing with UV materials is that UV coatings are more expensive to use than conventional coatings. Although the coating cost per gallon can be sometimes two, three or four times the cost per gallon of a conventional coating, one must consider the solids content of the coating to make a true comparison.

For example, if you were using a 25% low solids coating today, you would need to apply 4 wet mils of coating to get 1 dry mil. If you used a 100% solids UV formulation, only 1 wet mil would need to be applied to achieve the same end result of 1 dry mil. In this example, considering only the coating mileage cost, the amount of UV coating needed to apply the same dry film is four times less than the conventional coating as shown in Figure 1. The UV material out of the bucket could be four times more expensive per gallon, but it would cost the same to coat your parts as if you were using a 25% solids coating.

Transfer Efficiency Factor

If the overall cost of the UV coating is more than with conventional coatings even after factoring in the difference in percent solids, one should consider maximizing spray transfer efficiency to offset the difference in coating cost. The following is an example taken from a comparative analysis for a customer who was applying a low solids solvent-based coating with a non-electrostatic air spray gun system. The applied cost of coating using the conventional system was compared to a 100% solids coating applied to the same parts with a highly efficient rotary atomizer system in Figure 2. You will notice that even though the UV coating is four times more expensive per gallon than the conventional coating, applying the same film build to the same parts actually costs less for the 100% solids UV coating when a higher efficiency spray system is incorporated into the equation.

To Reclaim or Not to Reclaim

For a user whose process is already very efficient or for situations where investing in new spray equipment may not be as economically attractive, it may be beneficial to reclaim and reuse the over-sprayed coating material. One

Figure 1: Coating solids comparison

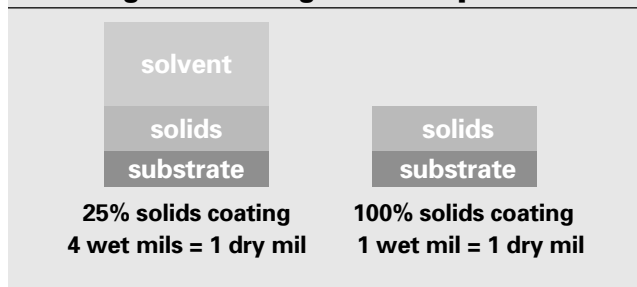

Figure 2: Coating cost comparison example

	Coventional Application	Rotary Atomizer UV Application
Coating Volume Solids	40%	100%
Measured Spray Transfer Efficiency	45%	85%
Cost per Gallon of Coating	\$24	\$95
Coating Sprayed/Hour @ 1 Mil Dry	8.3 gallons	1.76 gallons
Coating Dollars Spent/8-Hour Shift	\$1,594	\$1,338
Annual Coating Dollars Spent	\$382,560	\$321,128

of the many benefits of UV coatings is that they will not dry until they are exposed to high-intensity UV light, so a reclaim type spray booth is ideal for those applications where first pass transfer efficiency is lower than desired. However, the amount of reclaimable material must be considered before you invest in a reclaim booth.

In the previous example, the conventional system would generate approximately 4.5 gallons of over spray per hour, which is certainly enough material to justify a reclaim system. The rotary atomizer system would only generate one-quarter of a gallon-per-hour. That would not be enough to justify reclamation. However, there are some limitations to reclaim spray booths. For instance, although color changes are achievable in some reclaim booths, time needed to perform a color change is greater than a standard booth. It is important to note that no matter what type of spray booth is used, construction should be of corrosive resistant components, preferably stainless steel.

Other Payback Benefits

If you have done the economic analysis using the factors listed above and still need more justification, there are a few more major factors that should be considered. For example, investment of a UV-cure system is typically less than a gas-fired convection oven. A UV oven will often only consume only about one-tenth the floor space compared to a convection oven. Factor in your cost per square-foot of space per annum into the justification. An extra benefit to less space is that the UV lamps will also typically cost less to operate. It's difficult to quantify the numbers because each application will have different requirements, but it is safe to say that the bigger the convection oven needed, the more substantial the savings will be with a UV-cure system. This is true for not only the initial investment but also for operating costs. Recent developments in UV-lamp cure methodology can make the investment even lower when reciprocating lamps are used in place of fixed lamps. Reciprocating lamps operate on the same principle as reciprocating spray guns; both cover more part area with fewer devices. A project that may require 10 or 12 fixed lamps per side can be done with two or four lamps mounted on a reciprocator (Figure 3) as long

as the proper UV exposure time is accomplished.

Reduction of work-in-process, higher throughput capability and lower cycle times are also important factors. Many times a finisher doesn't know he is producing rejects until after the finishing process is complete. With a

conventional line, this may mean there are hundreds or even thousands of parts on the line. With UV, because of the nearly instantaneous cure and the shorter line needed, the amount of parts on the line can be minimized, thus avoiding costly rejects. Lamps are also designed to turn on and off quickly, so if the line stops, the cure stops until the line starts back up again. With a convection system, if the line stops, the parts in the oven will be overbaked. This can cause film faults such as discoloration and film brittleness.

One of the more tangible benefits of using a UV coating is the ability to lower your VOC output. Today, there are many formulations available that are considered 100% solids, meaning they contain no volatile solvents. UV coatings can be an alternative to costly abatement equipment or the need to switch to powder coating. The benefit is even greater if you are already spraying your product with liquid coating materials, because the initial invest-

Figure 3: Reciprocating UV lamps

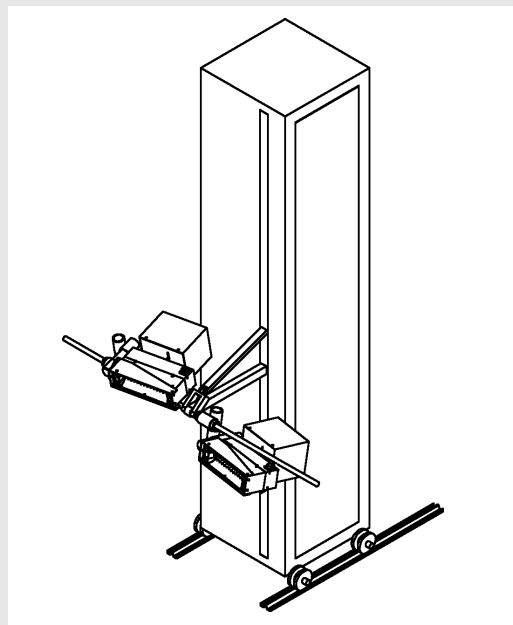

ment is considerably lower than putting in all new processing equipment. Most existing equipment such as spray booths, conveyors, etc. can be used.

What About Fluid Handling Equipment?

Most UV materials will require stainless steel wetted parts to avoid corrosion issues. In addition, many UV materials are shear sensitive, which eliminates the use of standard piston style pumps. Pressure vessels will work well with UV materials as long as the viscosity doesn't cause a concern. In the case where heat is used to artificially lower the viscosity of the coating, diaphragm pumps work best because you can set up a closed loop circulating system to supply multiple spray devices if necessary.

Can I Use My Existing Spray Guns?

Many UV formulations are easily sprayable out of air spray, HVLP, airless and air assisted airless guns. Sometimes heat will help to lower viscosity of these materials. In cases where the coating is too viscous for these types of spray devices to efficiently use them, it's best to use a high-speed rotational atomizer. The rotational atomizer can provide more atomization consistency and better control over particle size. Moreover, rotary atomizers are more dependent upon electrostatic attraction to the product being coated, which will increase your overall transfer efficiency, thus helping with the economic justification.

Conclusion

There are many benefits to using UV-liquid coatings. This article has touched on a few issues one should consider when comparing UV coatings to other conventional application choices. This article is not meant to be all-inclusive as there are many more factors to consider. Each project has its own unique set of circumstances, which can create a sliding scale of importance to each issue. It is important to carefully compare each factor in any process comparison and rate them in your final decision. ■

—David Hagood is a liquid systems specialist at Nordson Corporation, Amherst, Ohio.



Winter Member Meeting

The *last* member meeting before
RadTech 2002
Conference and Trade Show will
be at the Tampa Airport Marriott.

January 28, 2002

Focus Groups 12-6pm (evening reception)

January 29, 2002

General Session & Committees 8am-2pm
(free luncheon)

Register for the meeting online at
www.radtech.org.

To make a hotel reservation, please call
Marriott Reservations 1-800-228-9290 or
407-812-6040. You must mention that
you are attending the RadTech Winter
Meeting at the Tampa Airport Marriott.

Room rate of \$159 per room is available
through 1/7/02
...so reserve **EARLY**.

Contact RadTech for more information
(301) 664-8408.

RADTECH
INTERNATIONAL
NORTH AMERICA