

ValveMate™ 7060RA Controller

Operating Manual

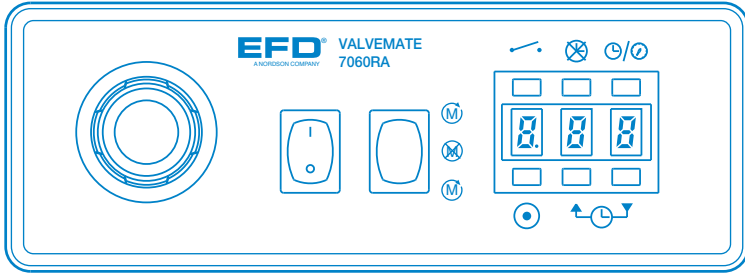

For order purpose, please refer to this # 7014235

IMPORTANT!
Save this Sheet.

Forward to
Maintenance or
Tool Crib Supervisors

Electronic pdf files of EFD manuals are also available at www.nordsonefd.com



Introduction

The ValveMate 7060RA provides nozzle air and drive motor on/off control for Nordson EFD Radial Spinner and Radial Spray Valve Series. The controller incorporates unique microprocessor circuitry to provide exact time control and interact with the host computer. A built-in air-pressure regulator provides LVLP (low volume low pressure) nozzle air to ensure high transfer efficiency without overspray. The ValveMate 7060RA is simple to use and will operate many millions of cycles without maintenance.

The EFD Pledge

Thank You!

You have just purchased the world's finest dispensing equipment.

I want you to know that all of us at EFD value your business and will do everything in our power to make you a satisfied customer.

If at any time you are not fully satisfied with our equipment or the support provided by your EFD Product Application Specialist, please contact me personally at 800.556.3484 (US), 401.431.7000 (outside US), or jeffrey.pembroke@nordsonefd.com.

I guarantee that we will resolve any problems to your satisfaction.

Thanks again for choosing EFD.

Jeff Pembroke

Jeffrey Pembroke, President

Contents

Introduction	2
Specifications	3
Operating Features	5
Controller Setup	6-8
Connecting More than One 7060RA Controller	9
Input / Output Connections	10-11
Troubleshooting Guide	12
Schematic and Replacement Parts List	13
Warranty	14
Notes	15

Specifications

Size: 19 x 14 x 7 cm (7.5" W x 5.6" D x 2.7" H)

Weight: 1.63 kg (2.99 lb)

Cabinet: Aluminum

Input AC (to power supply): 100-240 VAC(+/-10%) ~, 50/60Hz, 0.8A

Output voltage (from power supply): 30VDC -1.2 Amp maximum

Output circuit fuses: 5 x 20 mm cartridge fuses 315mA

Feedback Circuits: 5 to 24 VDC NC solid-state switch 250mA maximum

Initiate Circuit: 5 to 24 VDC momentary or dry contact closure

Air Input: 70 psi (4.8 bar)

Cycle Rate: Exceeds 400 per minute

Time Range: .001 to 99.9 seconds

Ambient Operating Conditions: Temperature: 5°C to 45°C (41°F to 113°F)

Humidity: 85% RH at 30°C non-condensing

Height above sea level: 2000 meters max (6,562 feet)

This equipment is for indoor use only.

Product Classification:

Installation Category II

Pollution Degree 2

Note: Specifications and technical details are subject to engineering changes without prior notification.

RoHS标准相关声明 (China RoHS Hazardous Material Declaration)

产品名称 Part Name	有害物质及元素 Toxic or Hazardous Substances and Elements					
	铅 Lead (Pb)	汞 Mercury (Hg)	镉 Cadmium (Cd)	六价铬 Hexavalent Chromium (Cr6)	多溴联苯 Polybrominated Biphenyls (PBB)	多溴联苯醚 Polybrominated Diphenyl Ethers (PBDE)
金属转接头 All Brass Fittings	X	0	0	0	0	0
<p>0: 表示该产品所含有的危险成分或有害物质含量依照EIP-A, EIP-B, EIP-C的标准低于SJ/T11363-2006 限定要求。 Indicates that this toxic or hazardous substance contained in all the homogeneous materials for this part, according to EIP-A, EIP-B, EIP-C is below the limit requirement in SJ/T11363-2006.</p> <p>X: 表示该产品所含有的危险成分或有害物质含量依照EIP-A, EIP-B, EIP-C的标准高于SJ/T11363-2006 限定要求。 Indicates that this toxic or hazardous substance contained in all the homogeneous materials for this part, according to EIP-A, EIP-B, EIP-C is above the limit requirement in SJ/T11363-2006.</p>						

Operating Features

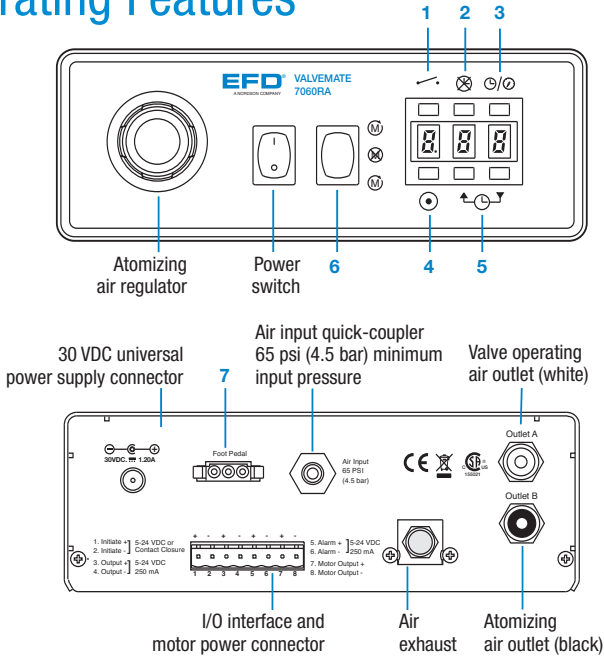

1. Cycle / Test

Press to initiate one complete dispense cycle. Press again to interrupt a timed cycle. Press and hold while in the time override mode for continuous cycle. Release to stop.

2. Time override

Press to override timed deposit mode. Display will show (---). While in this mode, dispensing is manual using the cycle button, voltage initiate source or foot pedal (optional, #7016714)).

3. Time/Pressure and PSI/BAR toggle

Press to change digital display from valve open-time to atomizing air pressure. Press and hold for three seconds to toggle between psi and bar.

4. Program

Press to clear display to zeros. Display flashes bright/dim while in program mode. Press cycle

button and hold until proper amount is sprayed. Total spray time will be displayed. Press program button again to lock in spray time.

5. Time set

Press to change time setting up or down. Press and release to single step.

6. Motor control mode switch

Switch from OFF (X) to continuous ON (M) for most applications or to intermittent ON (M) for low cycle use.

7. Foot pedal connector

If using the optional foot pedal, press the pedal momentarily to initiate the controller. To interrupt a timed dispense cycle, press the pedal again.

Controller Setup Schematic

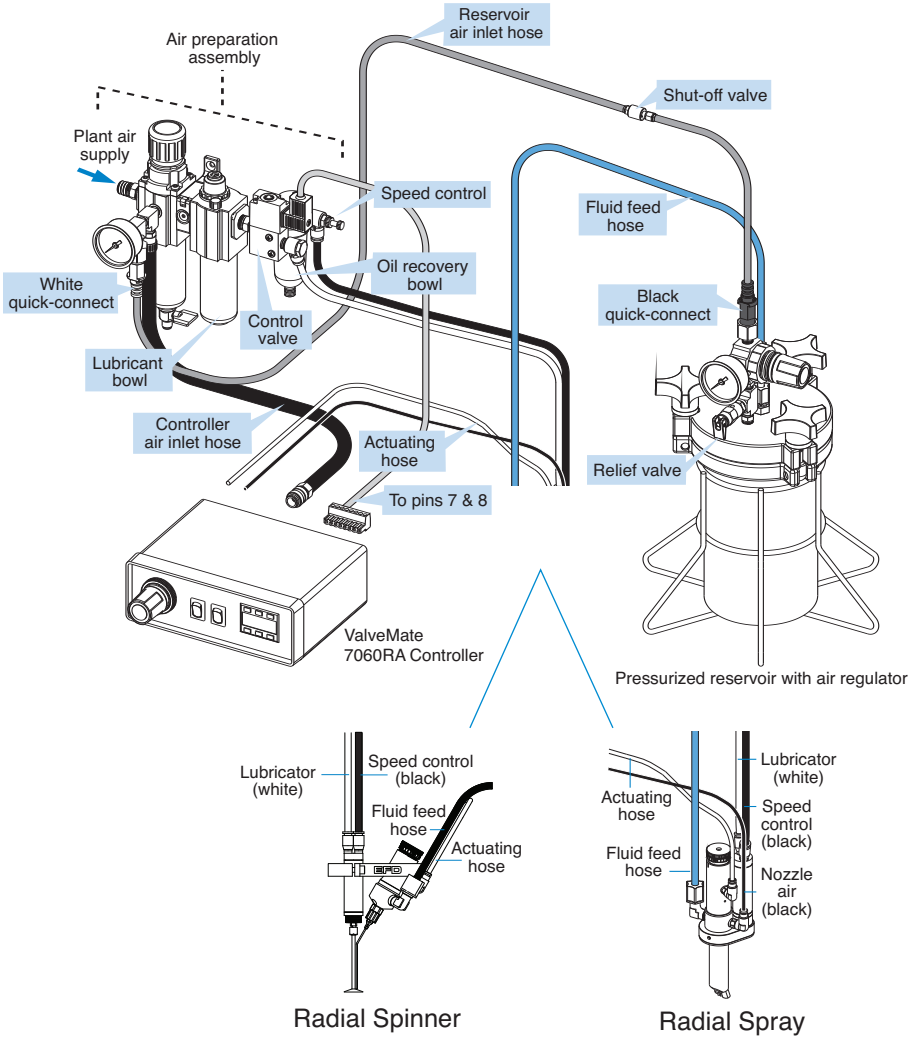

Note: For specific Radial Spray / Radial Spinner installation instructions, refer to Setup / Installation Guidelines that are included with respective Radial Spray / Radial Spinner device.

Controller Setup

Note: The 7060RA can operate two Radial Spray or Radial Spinner valves. A manifold kit (7021650: dual valve adapter kit) is available to connect a second valve to the controller, air preparation assembly and fluid reservoir.

Mounting

Use the universal mounting bracket (included) to mount the controller either over or under the cabinet. The bracket allows the controller to pivot 30° from a horizontal position. For panel mounting, a panel mount bracket kit is available (#7020501).

Input Power

A universal 30 VDC remote power supply is included with each ValveMate 7060RA. Select a convenient location and connect to appropriate input voltage.

Initiate Connection

The 7060RA can be operated by applying a 5 to 24 VDC pulse to terminal pins 1 and 2, or providing contact closure across pins 5 and 7. Alternatively, a foot pedal may be ordered (#7016714) and plugged into the connector located on the rear panel.

Air preparation assembly

Please follow the diagram on page 6 to set up the air supply circuit.

1. Mount the air preparation assembly and connect it to the plant air supply.
2. Connect the controller's black air-inlet hose to the 7060RA air inlet quick coupler.
3. Connect the control valve cable to the 7060RA. Firmly push the connector into the receptacle.

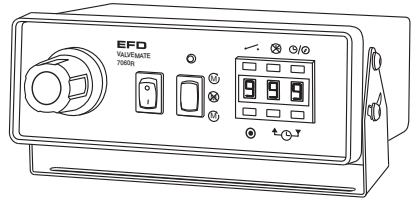

4. Remove the lubricator bowl by pushing up and turning counterclockwise. Fill bowl 2/3 full with the air lubricant supplied (Amflo 1220-4 air tool oil, EFD #7021820). Reinstall by pushing up and turning clockwise. The lubricator is pre-set to deliver the proper amount of oil.
5. The motor lubricant is captured in the oil recovery bowl and should be emptied periodically. Do not reuse.
6. The motor speed control is factory set to provide a rotor speed of approximately 2500 RPM. This setting can be changed if the rotor appears to start slow, runs slow or if the optional dual valve kit is installed. Avoid excessive speed that can cause distortion of the spray pattern. Rotor speed has no effect on the total amount sprayed or spun onto cylinder wall ID.
7. Set the air pressure regulator to a minimum of 70 psi (4.8 bar).

Continued on page 8.

Controller Setup (cont'd)

Power

1. Turn the power switch on.
2. Press the time override button to place the controller in manual mode (--).

Radial Spray / Radial Spinner Installation

1. Set the atomizing air pressure on the controller to 25 psi (1.7 bar). This is a starting point and may require adjustment to provide the desired coverage.
2. Atomizing air is programmed to continue for .250 seconds after the valve closes and is acceptable for most applications. To adjust this time, press the time override button while turning the power switch ON. SEL will appear on the display. Use the time set button to alter the delay time. Press the time override button to store the new setting.

Radial Spinner

1. Atomizing air pressure is not required for the Radial Spinner system. Set atomizing air pressure to 0.
2. Set spinner cycle delay time. Delay time is factory set to continue for .250 seconds after the dispense valve closes. This is acceptable for most spinner applications. To adjust this time, press the time override button while turning the power switch ON. SEL will appear on the display. Use the time set button to alter the delay time. Press the time override button to store the new setting.

Connecting more than one 7060RA Controller

1. Voltage Initiate Circuit

To start the dispense cycle for multiple 7060RA controllers at the same time, connect the voltage initiate circuit in parallel as illustrated.

Note: The amperage consumption for the voltage initiate circuit will increase with each controller that is connected. The initiate power supply should be sized accordingly.

1. Parallel circuit diagram for **Voltage Initiate**.

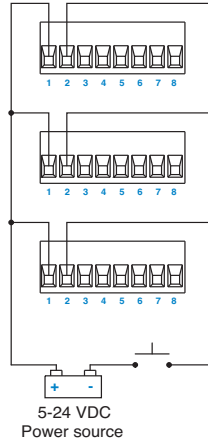

2. End-of-Cycle Feedback Circuit

This circuit will ensure that the end-of-cycle signal will come from the last 7060RA to complete a dispense cycle. Connect in series as illustrated.

Note: There will be a maximum voltage drop of 2.0 VDC through the feedback circuit with each 7060RA that is added to the series. The input power should be adjusted for this drop to ensure that the required voltage is available to operate the load. Maximum input voltage to terminals 3 and 4 must not exceed 30.0 VDC.

2. Series circuit for **End-of-Cycle Feedback** feature. A relay is illustrated as one example for utilizing the feedback circuit.

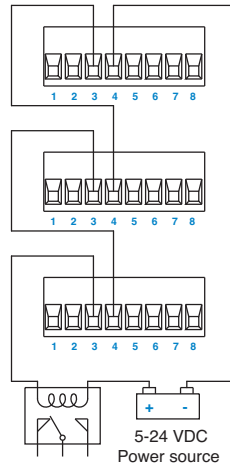

Input/Output Connections

1. Voltage Initiate Circuit

The controller may be initiated with a 5 to 24 VDC signal or contact closure across pins 1 and 2. The signal can be momentary (no less than 0.02 seconds) or maintained. A new cycle will begin once power is removed and then applied again or contacts are opened and closed again.

2. End-of-Cycle Feedback Circuit

Upon completion of a dispense cycle, an open collector circuit closes and remains closed until the next dispense cycle. This circuit can be utilized to signal back to a host computer, start another device in sequence or other operations that need to be tied into completion of the dispense cycle.

Upon closure, power from an external 5 to 24 VDC source is allowed to pass through the circuit to operate a load. The load illustrated is a relay, but this could be any device that will operate within the 5 to 24 volt range. Power consumption of the load must not exceed 250mA.

3. Alarm

The controller monitors the motor's current draw. If an overload or no load condition is detected, the controller will shut-off motor power. An open collector circuit will close and remain closed until the motor control mode switch is turned-off. This circuit is used to signal the host computer that a motor or wiring failure has occurred..

Note: For applications using more than one 7060RA, see page 9 for connection instructions.

I/O Connection

The 8 pin D connector and internal circuitry provide external initiate and end-of-cycle feedback signal. The pin connections are shown below.

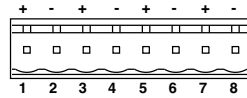

Pin	Function
1.	Initiate +
2.	Initiate -
3.	Output +
4.	Output -
5.	Alarm +
6.	Alarm -
7.	Control valve +
8.	Control valve -

Input/Output Connections

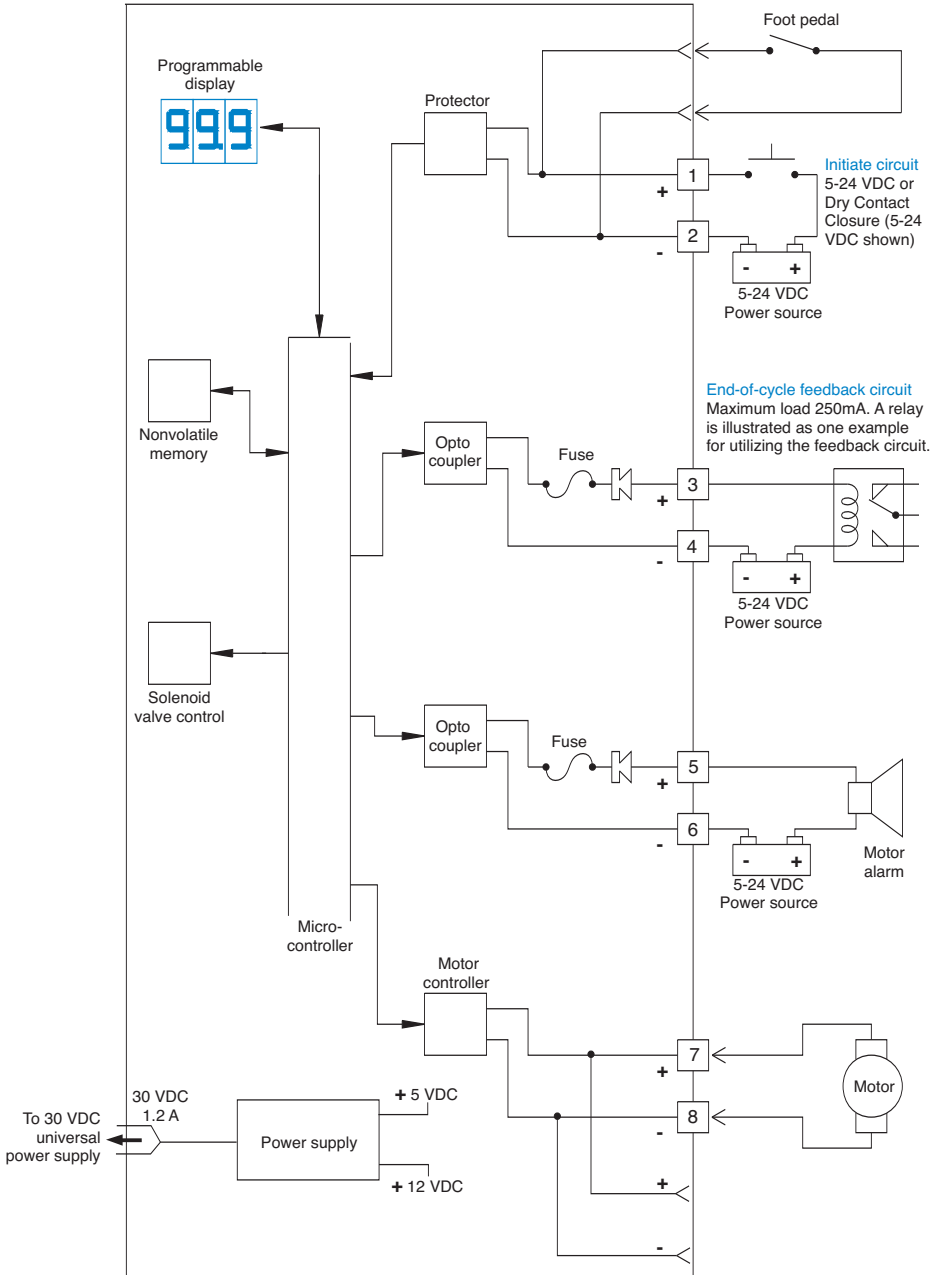

Troubleshooting Guide

Trouble	Possible cause and correction
No power	Be sure that there is power at the wall receptacle.
End-of-cycle feedback circuit is not functioning	Ensure that the external voltage to the circuit is between 5 and 24 VDC and that the load does not exceed 250mA. If the circuit has been overloaded, the fuse may have blown. Replace fuse, if necessary.
Valve does not spray below 0.15 second time setting	Response delay in pneumatic circuit does not allow the valve to open when time is at or below 0.015 seconds. Increase time.
Inconsistent deposits	<p>Low valve operating pressure can cause inconsistent output. Make sure pressure is set at 70 psi (4.8 bar).</p> <p>Check controller and reservoir air pressure readings to be sure air pressure is not varying.</p> <p>Air bubbles in the material can cause inconsistency. For best results, remove all air bubbles.</p> <p>Ensure that the controller is not in time override mode.</p>
Timer seems inoperative	Check to be sure time override mode is off.

If trouble cannot be corrected, or if you need further assistance, **please contact us.**

Schematic and Replacement Parts List

- | | | | |
|------------|--------------------------------------------------|-------------|----------------------------------------------|
| 1. 7016405 | Regulator assembly 0 to 30 psi,
0 to 2.07 bar | 10. 7016831 | 1/8 NPT x 1/4 barb - low profile |
| 2. 7016434 | Control solenoid assembly | 11. 7016832 | 1/8 NPT x 1/4 barb 90° - brass |
| 3. 7016435 | Atomizing solenoid assembly | 12. 7014281 | DC power supply - 7060RA |
| 4. 7016454 | Display PCB assembly | 13. 7020769 | Exhaust muffler |
| 5. 7016471 | Foot pedal receptacle assembly | 14. 7020770 | Power switch |
| 6. 7016934 | Push-in fitting,
1/8 NPT x 1/4 OD tube | 15. 7016508 | Motor mode switch assembly |
| 7. 7021816 | Bulkhead fitting,
1/8 NPT x 5/32 OD tube | 16. 7020833 | Fuse – output protection (2) |
| 8. 7016751 | 1/4" OD x .160" ID tubing | 17. 7012985 | 30 VDC universal power supply
(not shown) |
| 9. 7016822 | Air input quick-connect | | |

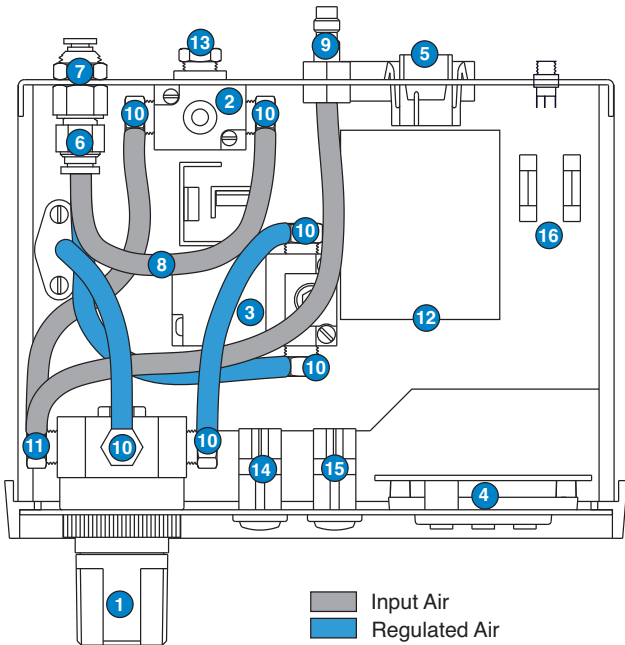

Nordson EFD ONE YEAR LIMITED WARRANTY

All components of Nordson EFD spray valves and ValveMate controllers are warranted for one year from date of purchase to be free from defects in material and workmanship (but not against damage caused by misuse, abrasion, corrosion, negligence, accident, faulty installation or by dispensing material incompatible with equipment) when the equipment is installed and operated in accordance with factory recommendations and instructions. Nordson EFD will repair or replace free of charge any part of the equipment thus found to be defective, on authorized return of the part prepaid to our factory during the warranty period. For the spray valve, the only exceptions are those parts which normally wear and must be replaced routinely such as, but not limited to, needles, needle packings and nozzles.

In no event shall any liability or obligation of Nordson EFD arising from this warranty exceed the purchase price of the equipment. This warranty is valid only when oil-free, clean, dry, filtered air is used.

Nordson EFD makes no warranty of merchantability or fitness for a particular purpose. In no event shall Nordson EFD be liable for incidental or consequential damages.

Notes

For Nordson EFD LLC sales and service in over 30 countries, contact Nordson EFD or go to www.nordsonefd.com

East Providence, RI USA
USA & Canada: 800.556.3484;
+1.401.431.7000
info@nordsonefd.com

Dunstable, Bedfordshire, UK
0800 585733; +44 (0) 1582 666334
Ireland 00800 8272 9444
europe@nordsonefd.com

China: +86 (21) 3866 9006
china@nordsonefd.com

Singapore: +65 6796 9522
sin-mal@nordsonefd.com

The Wave Design is a trademark of Nordson Corporation
©2011 Nordson Corporation 7060RA-MAN-01 (7014236) v042711-Rev.2



This equipment is regulated by the European Union under WEEE Directive (2002/96/EC). See www.nordsonefd.com for information about how to properly dispose of this equipment.

The logo for Nordson EFD, featuring a blue curved line above the word "Nordson" in a bold, blue, sans-serif font, with "EFD" in a smaller, bold, black, sans-serif font below it.