

MicroCoat[®] Flow Guard Operating Manual

MC480M Series

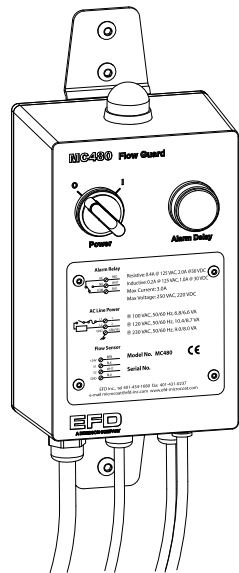
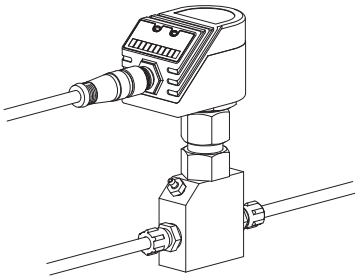
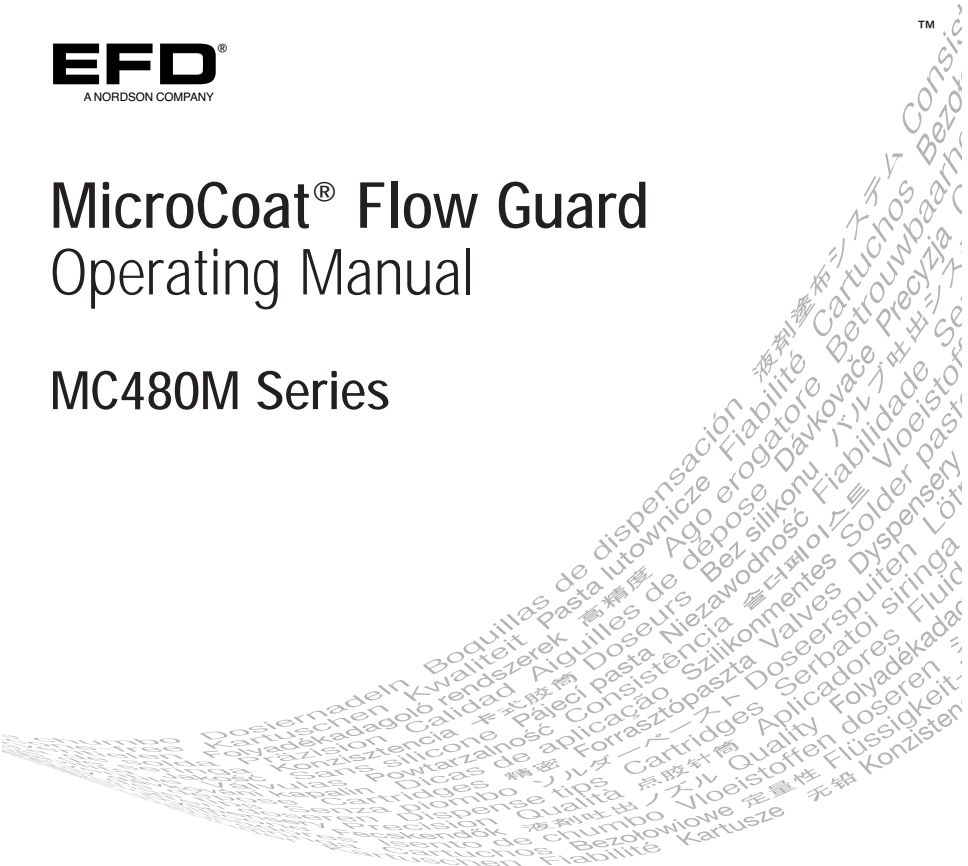

Contents

Introduction	3
Specifications	4
Features	5
MC800 System Assembly	6-7
Priming the System	7
System Diagram	8-9
MC4000 System Assembly	10
MC2000 System Assembly	10
System Operation	11-13
Programming the Sensor	11
Making Flow Adjustment	12
Setting the Switch Points	13
Preventive Maintenance	14
Troubleshooting Guide	14
Replacement Part Numbers	15
Warranty	Back Cover

Introduction

The purpose of the Flow Guard system is to signal a high or low flow condition. The MC480M operates on the calorimetric principle. As lubricant flows over the tip of the sensor, it removes thermal energy from the sensor. The amount of power required to maintain the temperature of the sensor is proportional to fluid flow. Coupled with the sensor is a controller that provides a logic interface between the sensor output and the stamping/forming press. The MC480M system provides an alarm signal when lubricant flow varies enough to cross either the low flow or high flow set points. The signal is typically connected to an E-Stop circuit to shut the press down when an alarm condition is present. The set points are determined empirically and are based on an acceptable range of flow determined by the user.

The MC480M Flow Guard system is designed to work together with the MicroCoat lubrication system. Control pressure used to operate the MicroCoat System also provides press status input to the MC480M.

Upon initiation of control air:

1. The MicroCoat system valves open and lubricant begins to flow.
2. The MC480M alarm system becomes active and a 30-second delay period commences while the sensor completes a start-up sequence.
3. The sensor's green LED settles between the upper and lower control switch points indicating the flow is recognized and being monitored.

When flow exceeds an alarm set point:

1. The MC480M stops press operation through the press E-Stop circuit.
2. The system "control air" is turned off.
3. The alarm indicator illuminates.

Once the error condition is corrected, the press is restarted resuming "control pressure" and flow monitoring.

Specifications

MC480 Controller

Size:	11.9 W x 19.1 H x 8.9 D cm (4.7" x 7.5" x 3.5")
Weight:	1.45 kg (3.20 lb)
Input voltage:	MC480M-120: 120 VAC, 50/60 Hz, 10.4/8.7 VA MC480M-220: 220 VAC, 50/60 Hz, 9.0/8.0 VA
Resistive:	0.4A @ 125 VAC, 2.0A @ 30 VDC
Inductive:	0.2A @ 125 VAC, 1.0A @ 30 VDC
Maximum current:	3.0A
Maximum voltage:	250 VAC, 220 VDC
Minimum air pressure:	40 psi (2.76 bar)
Protection:	IP67

Note: Specifications and technical details are subject to engineering changes without prior notification.

MC480-FS Flow Sensor

Size:	4.1 W x 10.9 H x 7.1 D cm (1.6" x 4.3" x 2.8")
Weight:	0.47 kg (1.03 lb)
Operating voltage:	20-36 VDC
Current rating:	2 x 125mA, short-circuit protection Reverse polarity protection/overload protection
Temperature range:	-25°C to 80°C (-13°F to 176°F)
Protection:	IP67
Sensor material:	Type 316 stainless steel

Meets CE standards

RoHS标准相关声明 (China RoHS Hazardous Material Declaration)

产品名称 Part Name	有害物质及元素 Toxic or Hazardous Substances and Elements					
	铅 Lead (Pb)	汞 Mercury (Hg)	镉 Cadmium (Cd)	六价铬 Hexavalent Chromium (Cr6)	多溴联苯 Polybrominated Biphenyls (PBB)	多溴联苯醚 Polybrominated Diphenyl Ethers (PBDE)
金属接头 All Brass Fittings	X	0	0	0	0	0
<p>0: 表示该产品所含有的危险成分或有害物质含量依照EIP-A, EIP-B, EIP-C的标准低于SJ/T11363-2006 限定要求。 Indicates that this toxic or hazardous substance contained in all the homogeneous materials for this part, according to EIP-A, EIP-B, EIP-C is below the limit requirement in SJ/T11363-2006.</p> <p>X: 表示该产品所含有的危险成分或有害物质含量依照EIP-A, EIP-B, EIP-C的标准高于SJ/T11363-2006 限定要求。 Indicates that this toxic or hazardous substance contained in all the homogeneous materials for this part, according to EIP-A, EIP-B, EIP-C is above the limit requirement in SJ/T11363-2006.</p>						

Features

1. **Power Switch**
Turns the system on and off.
2. **Alarm Delay Switch**
Starts a 3-minute delay that prevents press shutdown when setting new oil flow rate.
Push and hold for 3 seconds to cancel alarm.
3. **Alarm Indicator**
Illuminates when improper flow is detected—blinks in override mode.
4. **AC Power**
5. **E-Stop Circuit Connection**
6. **Control Air Input**
Activates the system when control air is supplied.
Minimum 40 psi (2.76 bar) required.
7. **Flow Sensor Connector**
8. **Fuse**
9. **Mode/Enter Switch**
Selection of menu items and acknowledgement.
10. **Learn/Set Switch**
11. **Function Display**
Green LEDs indicate flow in 10% increments within the display range (Low . . .High).
Red LED indicates alarm set point.

Controller

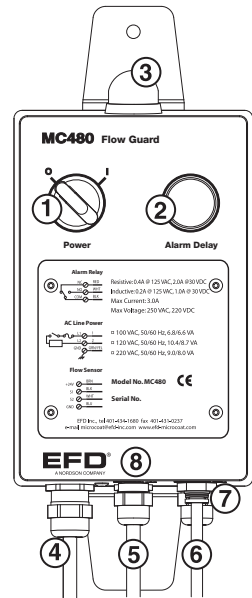

Flow Sensor

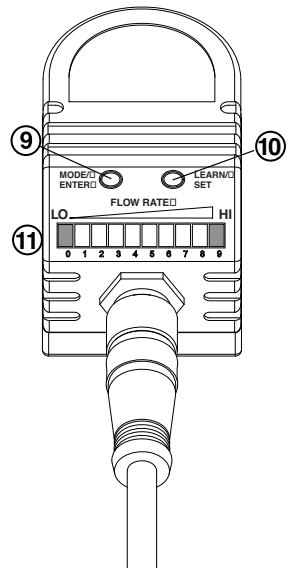



System Assembly

MC800

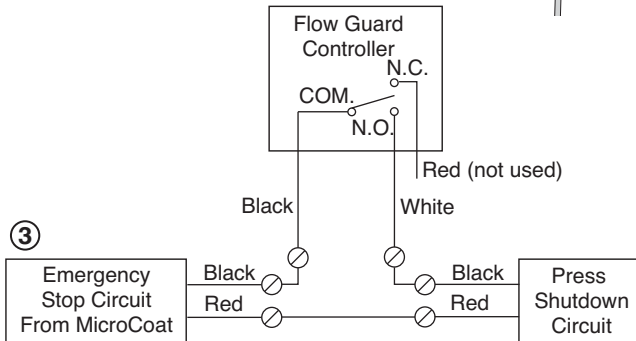
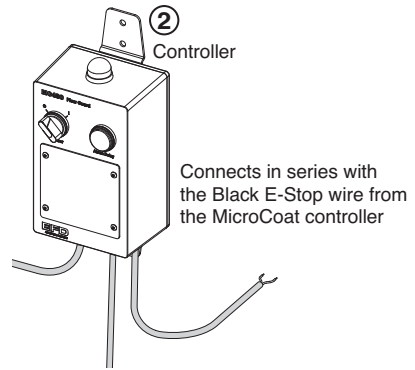
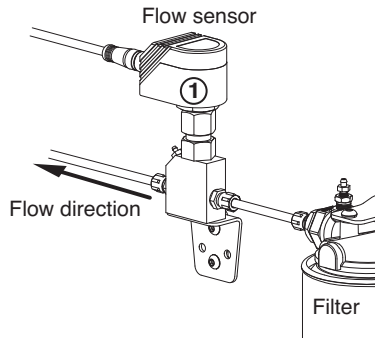
1. Install the flow sensor with adapter at the MCFILTER outlet using the supplied fittings. The bar graph side of the unit should face the downstream flow direction.
2. Find a suitable location where ambient temperature is fairly constant, then securely mount the controller and flow sensor. The MicroCoat stand is an ideal location if used.
3. Connect the MC480M E-Stop circuit wire to the MicroCoat E-Stop circuit.
4. Refer to the schematic and connect the controller power cord to an appropriate source.



④ **Caution!**
 Risk of electric shock

Warning!
 Disconnect power before removing cover

AC Line Power

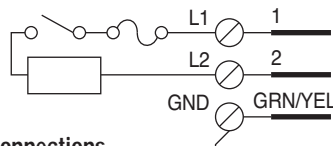

IMPORTANT: Electrical connections must be made by a licensed electrician.

5. Install the supplied tee fitting onto the MicroCoat control air coupling, and connect the grey hose from the air tee on the controller to the input on the Flow Guard controller.
6. Secure the connecting cable to the flow sensor.

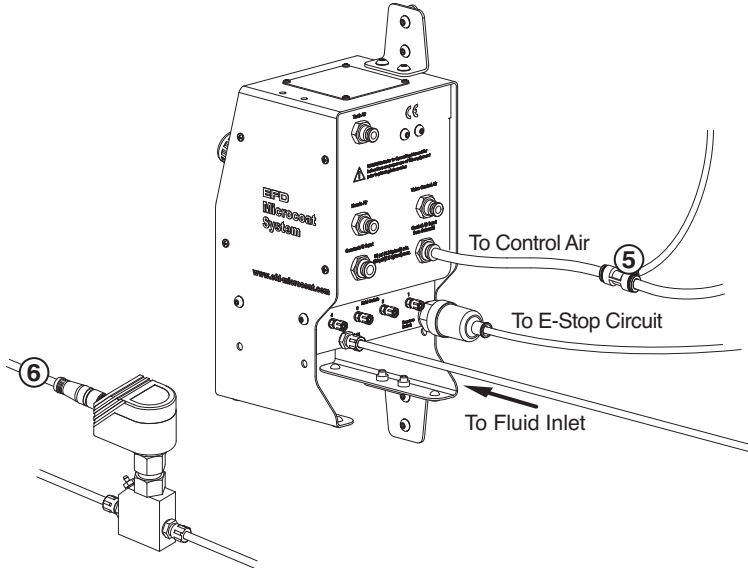





Priming the System

IMPORTANT: The system must be primed free of air for proper performance.

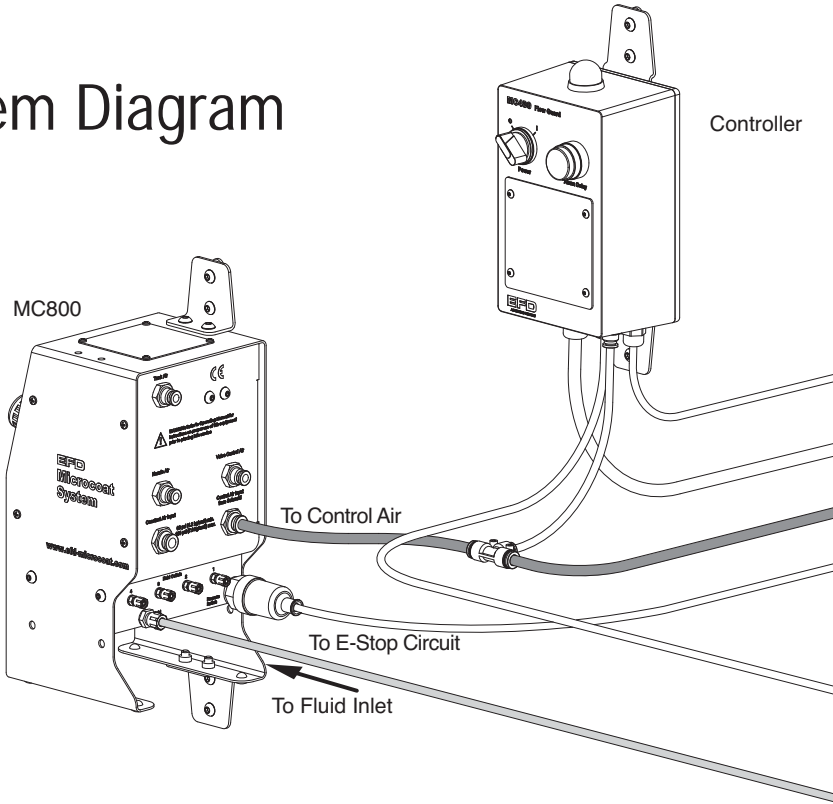
Refer to the System Setup instructions in the MC800 MicroCoat System manual for detailed explanation on priming the system.

System Diagram



-  Connects in series with the Black E-Stop wire from the MicroCoat controller
-  To AC Line Power
-  From Control Air Solenoid
-  To E-stop Circuit

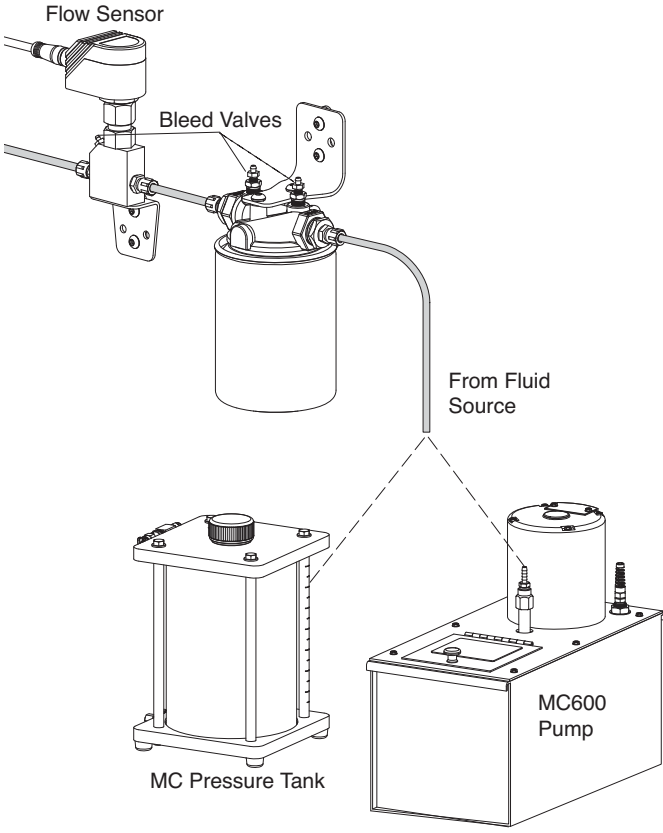

System Assembly

MC4000

- A. Refer to the figure to the right for installation assistance. Follow steps 1 through 4 on MC800 System assembly instructions (page 6).
- B. Install the supplied tee fitting onto the MicroCoat control air coupling ① and connect the grey hose from the air tee on the controller to the input on the Flow Guard controller.
- C. Secure the connecting cable to the flow sensor.

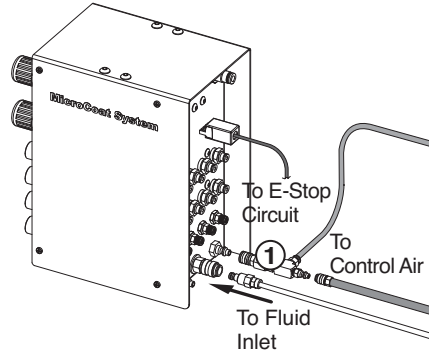

System Assembly

MC2000

- A. Refer to the figure to the right and remove the pipe plugs from ports ① and ②.
- B. Install the flow sensor with adapter into the rear hole ② of the MC2000. The bar graph side of the sensor should face towards the front of the MC2000.
- C. Install the special fitting with O-ring into the side port ① of the MC2000 and tighten.
- D. Using the fittings and tubing supplied, connect the side port ① to the inlet of the flow sensor as shown.

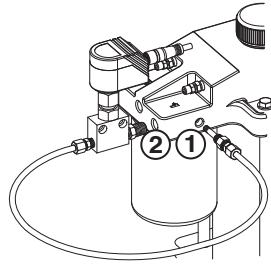

Note: Complete the MC2000 assembly using steps 4 through 6 on pages 6 and 7.

System Assembly

Programming the Sensor

①

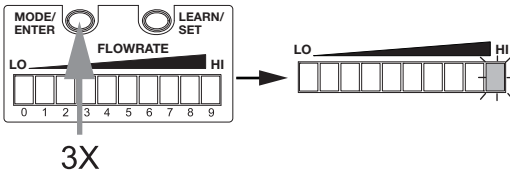

1. Set the desired flow and keep it constant. On the sensor, push the Mode/Enter button three times to enter the programming mode.

②

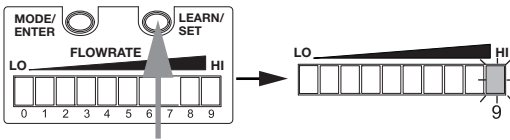

2. Push and hold the Learn/Set button until LED #9 begins to FLASH, then release the button.

③

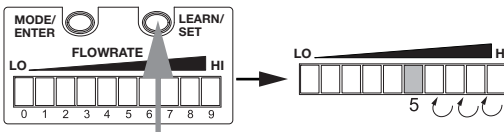

3. Push the Learn/Set button sequentially until the LED is at #5 position, centered between the upper and lower limits.

④

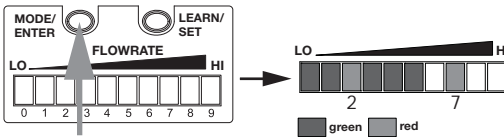

4. Push the Mode/Enter button once to save this setting.

The system is now set to monitor flow and trigger the E-Stop circuit if the minimum switch point (factory set at #2) or the maximum (factory set at #7) is exceeded.

Note: If no button is pushed for 20 seconds during the setting procedures, the unit returns to the operating mode with parameters unchanged.

Making Flow Adjustment

Making an adjustment to the flow volume may cause the flow sensor to cross the preset alarm set points. To avoid triggering the E-Stop circuit, the MC480M is equipped with an alarm delay. Initiating this delay provides three minutes to reset the flow and reprogram the sensor.

1. Push the Alarm Delay switch on the controller to initiate the 3-minute delay. The alarm indicator will begin to flash.

Note: If more time is required, pushing the switch again will restart the 3-minute delay.

2. Establish the new flow setting for the MicroCoat System.
3. Program the sensor as instructed on page 11.
4. Push and hold the Alarm Delay switch for 3 seconds to cancel the delay or just allow the time to run out. The alarm indicator will stop flashing.

Note: Switch points are factory set to LEDs #2 and #7. These settings should be right for most applications. If you require more or less sensitivity, follow the procedure on page 13 to change the switch points.

Setting the Switch Points

①

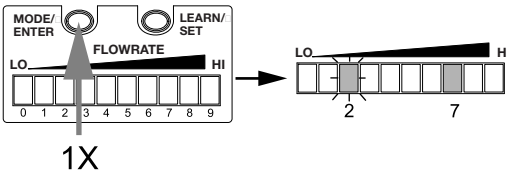

Low switch point

1. Push the Mode/Enter button once to enter the programming mode for the low switch point.
2. Push the Learn/Set button and hold. After 5 seconds, the flashing LED begins to move from left to right. Flashing LEDs move sequentially in 1% steps, and steady LEDs move sequentially in 10% steps. When the

flashing LED reaches the right side of the display, it jumps to the left side, and the steady LED moves one position.

For example: When flashing LED is at #4 and steady LED is at #6, the switch point is 64. Once the desired switch point has been reached, push the Mode/Enter button once to save the setting.

②

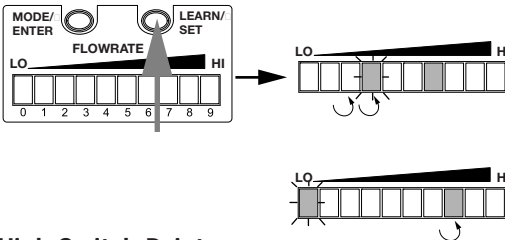

High Switch Point

1. Push the Mode/Enter button twice to enter the programming mode for the high switch point.
2. Follow step 2 above to set the high switch point.

Note: The low switch point must be lower than the high switch point.

Preventive Maintenance

The MC480M is designed for long life with minimal maintenance.

CAUTION: Before performing any maintenance, set the system pressure to the OFF position and disconnect power.

Check the sensor tip after the first month of operation to establish an appropriate cleaning schedule. Clean the sensor probe periodically.

Troubleshooting Guide

Unstable oil flow causes unit to switch off.

Unstable oil flow can be caused by air pressure fluctuations. Make sure the MicroCoat system pressure is stable.

The lubricant system may have entrapped air. This air, when it reaches a flow control, can cause a flow surge from the valve.

System trips off and indicates an underflow condition even though there is no air pressure fluctuation or air in the lubricant system.

Reset the minimum flow level by turning the MicroCoat system off, then push the Learn/Set button and hold until LEDs light step by step from left to right, then step by step from right to left. The low switch point will now be 20% above zero flow.

The low switch is slow to respond to an underflow condition.

The low switch point can be moved closer to the center of the bar graph. The low switch point is factory set at #2. Changing the setting to #3 will provide a faster response time. Refer to page 13 for this procedure.

Sensor is very unstable. Sometimes switching off low and at other times high.

Check the sensor probe for contamination and clean if necessary.

Check the sensor location. The bar graph display must face downstream.

Check to make sure the sensor is installed fully into the adapter.

The sensor must be located in an area that is away from air currents that can cause temperature changes. If necessary, wrap the sensor adapter with an insulating blanket.

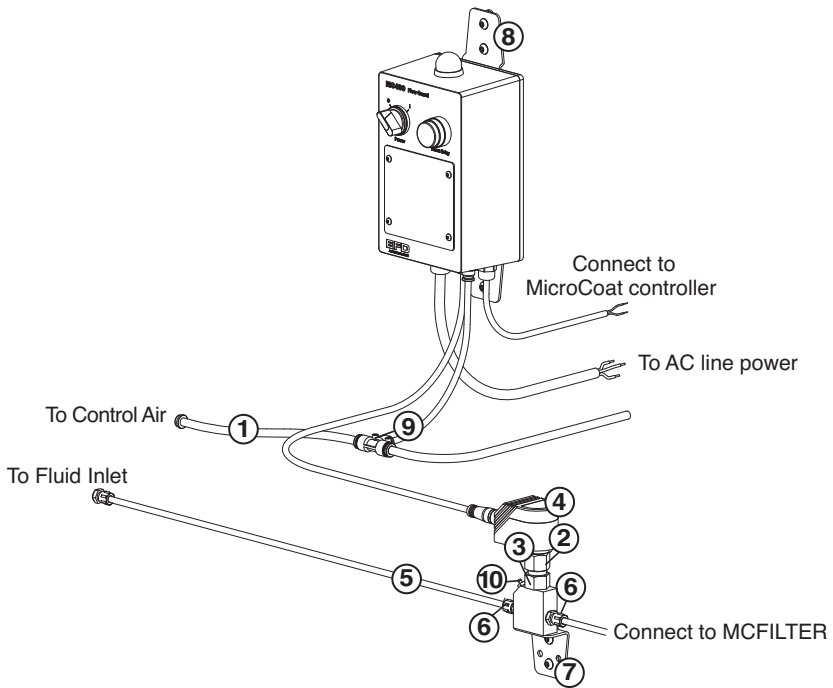

Replacement Part Numbers

- | | | |
|-----|----------|-----------------------------------|
| 1. | 8126-W | Tubing - 6 mm OD, urethane, white |
| 2. | 4070 | Sensor to adapter coupler |
| 3. | 4069 | Low flow adapter |
| 4. | 480FS | Flow sensor assembly |
| 5. | 2024-6mm | Tubing - 6 mm OD, urethane, blue |
| 6. | 8131 | Fitting - 1/8 BSPP x 6 mm OD barb |
| 7. | MC7302 | Sensor bracket |
| 8. | MC7301 | MicroCoat controller brackets |
| 9. | 8155 | Fitting - 8 mm x 6 mm push-in tee |
| 10. | 8150 | Bleed valve |
| 11. | 4084 | MC2000 sensor adapter (not shown) |

EFD TWO YEAR LIMITED WARRANTY

Seller warrants the MicroCoat MC480M Flow Guard system and components ("Product") to be free from defects in materials and workmanship for two years from date of purchase, provided Product is installed and operated in accordance with factory recommendations and instructions.

Seller will repair or replace free of charge any part of the equipment thus found defective, on authorized return of the part or product prepaid to our factory during the warranty period.

Repaired or replaced parts will be warranted for the remainder of the original two-year warranty.

This warranty specifically excludes damages or wear to Product caused by misuse, abrasion, corrosion, negligence, accidents, faulty installation or by the use of any contaminated or incompatible dispensing material with the Product.

The sole liability of Seller and the exclusive remedy of Buyer arising out of the supply or use of Product, whether arising under contract, tort (including negligence), strict liability or otherwise shall be the modification, adjustment, repair or replacement of the Product, or refund limited to the Product price.

SELLER AND BUYER AGREE THAT, IN CONSIDERATION OF THE ABOVE EXPRESS WARRANTY, ALL OTHER WARRANTIES AND GUARANTEES, OTHER THAN TITLE, EITHER EXPRESSED OR IMPLIED, INCLUDING WARRANTIES OF MERCHANTABILITY AND FITNESS FOR A PARTICULAR PURPOSE ARE EXCLUDED.



For EFD sales and service in over 30 countries,
contact EFD or go to www.efd-inc.com

EFD, Inc.

East Providence, RI USA

USA & Canada: 800-556-3484; +1-401-434-1680

info@efd-inc.com

www.efd-inc.com

EFD International Inc.

Dunstable, Bedfordshire, UK

0800 585733 or +44 (0) 1582 666334

Ireland 00800 8272 9444

europe@efd-inc.com

www.efd-inc.com

EFD, Inc., Asia

China: +86 (21) 3866 9166

china@efd-inc.com

www.efd-inc.com/cn

Singapore: +65 6796 9630

sin-mal@efd-inc.com

The Wave Design is a trademark of Nordson Corporation

©2008 Nordson Corporation MC480M-MAN-01 7023835 v022208



This equipment is regulated by the European Union under WEEE Directive (2002/96/EC). See www.efd-inc.com for information about how to properly dispose of this equipment.