

787MS-SS valve system produces spray patterns as small as 3.3 mm (0.130")

activators
coatings
inks
liquid fluxes
oils
silicones
solvents

EFD[®]
A NORDSON COMPANY

The 787MS-SS Series is a precision spray valve that uses low volume low pressure (LVLP) technology to produce uniform spray patterns between 3.3 mm and 19 mm (0.130 and 0.75") in diameter.

Innovative design uses a small gauge 0.3 mm – 0.1 mm (0.013" – 0.004" ID) disposable dispensing tip in place of a standard spray nozzle. This concentrates the LVLP air used to atomize the coating into uniform spray patterns over 30% smaller than EFD's standard spray valve configuration. Between shots the valve needle seats in the hub of the dispensing tip, virtually eliminating dead fluid volume.



Features

- High transfer efficiency
- No overspray or mist
- Medium- to low-viscosity fluids
- Consistent spray patterns
- Cycle rate exceeds 400/minute
- Low maintenance design



Electronic pdf files of EFD manuals are also available at www.efd-inc.com

www.efd-inc.com info@efd-inc.com USA & Canada 800-556-3484 Europe +44 (0) 1582 666334 Asia +86 (21) 3866 9166

Sales and service of EFD[®] dispensing systems are available worldwide.

Spray valve systems

The complete system includes the 787MS-SS dispense valve, ValveMate 8040 controller, and the fluid reservoir.

Expert technical assistance and high quality standards ensure productive, trouble-free performance. EFD offers a full line of reliable dispensing systems to meet your specific application requirements.

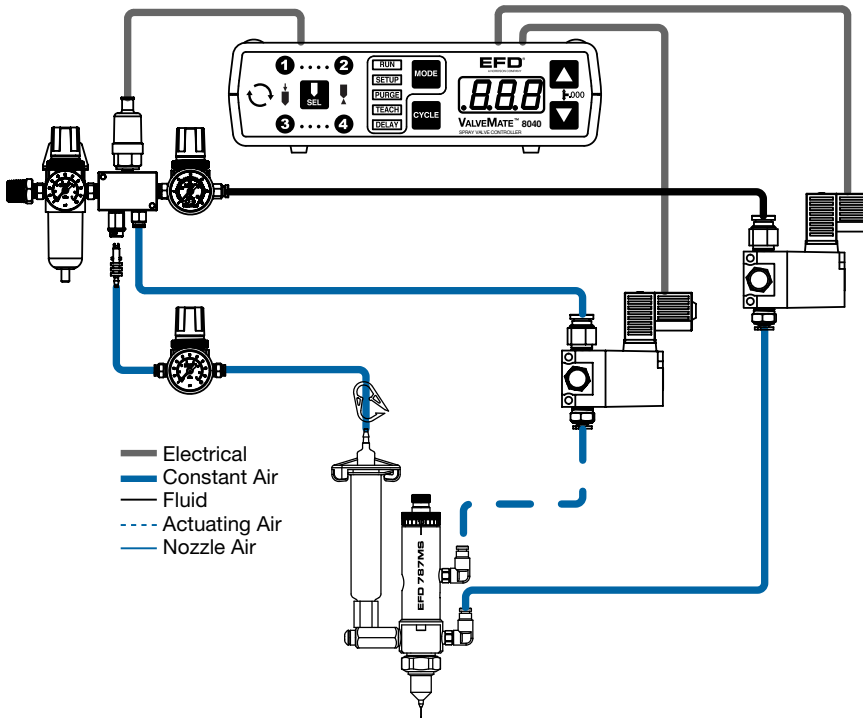

787MS-SS Valve

The 787MS-SS is a precision low volume low pressure (LVLP) spray valve that uses 23-33 gauge (0.013"-0.004" ID) dispensing tips to produce uniform spray patterns as small as 3.3 mm (0.130") wide.

Specifications:

Size: 131.6 mm length x 26.9 mm diameter (5.18" x 1.06")

Weight: 336 grams (11.8 oz)

Fluid body: Type 303 stainless steel

Air cylinder body: Type 303 stainless steel

Piston: Type 303 stainless steel

Needle: Type 303 stainless steel

Fluid inlet thread: 1/8 NPT female

Air cap: Type 303 stainless steel

Free flow orifice: 33 ga (.004, 0.10mm) to 23 ga (.013, 0.33 mm)

Needle packagings: PTFE

Mounting: ¼-28 UNF tapped hole

Maximum fluid pressure: 100 psi

Maximum operating temperature: 102°C (215°F)

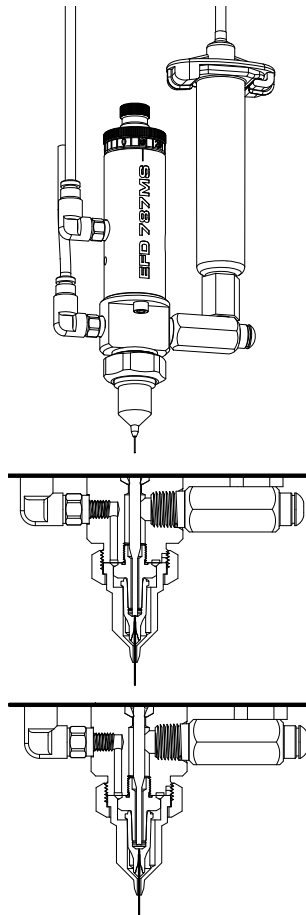

ValveMate 8040 Controller

The ValveMate controls valve open time and nozzle pressure. Its compact size allows the controller to be mounted near the valve for easy setup and spray adjustment.

- Multi-valve control- up to (2) spray valves
- Partner to Programmable Logic Controller (PLC)
- Easy control for consistent coverage
- Precise control of nozzle air pressure
- End-of-cycle air delay prevents valve from clogging
- End user convenience
- Maximum machine efficiency

Optional: XYZ Dispensing System

EFD's TT dispensing robot incorporates all functions of the ValveMate. Compact 3- or 4-axis tabletop system offers consistent coverage repeatability.

Work area: 325 x 325 x 100 mm or 525 x 525 x 100 mm.

Fluid Reservoirs

EFD reservoirs are supplied with precision, constant-bleed regulators to ensure consistent fluid pressure to the valve. Tank reservoirs are available in 1.0, 5.0 and 19.0 liter capacities. Cartridge sizes range from 2.5 to 32 ounces (75 cc to 950 cc).



For EFD sales and service in over 30 countries, contact EFD or go to www.efd-inc.com

EFD, Inc.

East Providence, RI USA

USA & Canada: 800-556-3484; +1-401-434-1680

info@efd-inc.com

www.efd-inc.com

EFD International Inc.

Dunstable, Bedfordshire, UK

0800 585733 or +44 (0) 1582 666334

Ireland 00800 8272 9444

europa@efd-inc.com

www.efd-inc.com

EFD, Inc., Asia

China: +86 (21) 3866 9166

china@efd-inc.com

www.efd-inc.com

Singapore: +65 6796 9630

sin-mal@efd-inc.com