



SECS/GEM Interface Option
(Version 4.8.3 and Higher)

for

Fluidmove for Windows[®]
(FmNT Version 4.8.3 and Higher)
(FmXP[®] Version 5.0 and Higher)

User Manual

P/N 7207036, Rev. A

NOTICE

This is an Asymtek publication which is protected by copyright. Original copyright date 2005. No part of this document may be photocopied, reproduced, or translated to another language without the prior written consent of Asymtek. The information contained in this publication is subject to change without notice.

Manuals on the Internet

For the convenience of Asymtek customers and field service representatives, copies of this manual can be downloaded from <http://www.asymtek.com/support/manuals.htm>.

Contact Us

Asymtek welcomes requests for information, comments, and inquiries about its products. General information about Asymtek can be found on the Internet at www.asymtek.com.

	
Headquarters	2762 Loker Avenue West Carlsbad, CA 92010-6603 USA
Toll Free:	1-800-ASYMTEK (1-800-279-6835)
Tel:	+1-760-431-1919
Fax:	+1-760-431-2678
E-mail:	info@asymtek.com
Website:	www.asymtek.com
Technical Support	
USA:	1-800-ASYMTEK (1-800-279-6835)
Other regions:	www.asymtek.com Tech Support

Trade Marks

Asymtek[®] and Fluidmove[®], are registered trademarks of Asymtek.
Microsoft[®], Windows[®], Windows NT[®], and Windows XP[®] are registered trademarks of Microsoft Corporation.

© Asymtek, 2005

TABLE OF CONTENTS

1	INTRODUCTION	1-1
1.1	Overview.....	1-1
1.2	Terminology.....	1-2
1.3	SECS/GEM – Fluidmove Compatibility	1-4
1.4	SECS Standard	1-4
1.4.1	SECS-I Clarifications	1-4
1.4.2	Physical Connection	1-5
1.4.3	SECS-I Blocks Transmitted	1-5
1.4.4	Interleaved Blocks	1-6
1.4.5	Simultaneous Transactions	1-6
1.5	SECS-II Clarifications	1-7
1.5.1	Data Format Types	1-7
1.5.2	Data Item Length Bytes	1-7
1.5.3	ASCII Data.....	1-7
1.5.4	Multi-Block Messages	1-7
1.5.5	Function Zero	1-7
1.6	GEM Standard.....	1-8
1.7	GEM Compliance	1-8
1.8	SEMI E10 Standard.....	1-10
1.9	SECS I / SECS II Parameters	1-11
1.9.1	SECS-I Parameters	1-11
1.9.2	SECS-II Parameters	1-11
1.9.3	GEM Configuration	1-12
1.10	State Diagrams.....	1-14
1.11	Machine Operation and the GEM Interface	1-15
1.11.1	Connecting to the Host.....	1-15
1.11.2	Device Identification	1-15
1.11.3	Clock.....	1-15
1.11.4	Loss of Communications Link: Spooling	1-16
1.11.5	Communications Error Messages	1-16
1.11.6	Normal Communications	1-16
1.11.7	SECS/GEM Setup Dialog Box in Fluidmove	1-19
1.11.8	Fluidmove Run Window Interface	1-23

2	MESSAGE SUMMARY	2-1
2.1	Host-to-Equipment Messages	2-1
2.2	Equipment-to-Host Messages	2-3
3	OPERATING CHARACTERISTICS	3-1
3.1	Communications States.....	3-1
3.1.1	Communications Finite State Description	3-2
3.1.2	Power Up.....	3-5
3.1.3	Related Variables	3-5
3.1.4	Compatibility	3-5
3.2	Control States.....	3-6
3.2.1	Control Finite State Description.....	3-7
3.2.2	Power Up.....	3-11
3.2.3	Related Variables	3-11
3.2.4	Related Events	3-12
3.3	Process States	3-12
3.3.1	E10 State.....	3-13
3.3.2	Equipment Process States	3-16
3.3.3	Related Variables	3-18
3.3.4	Related Collection Events	3-18
3.4	Data Collection	3-19
3.4.1	Variables.....	3-19
3.4.2	Are You There	3-19
3.4.3	Host Requests Status.....	3-19
3.4.4	Setting Equipment Constants.....	3-19
3.4.5	Event Reports.....	3-19
3.4.6	Time Driven Trace.....	3-20
3.4.7	Limits Monitoring	3-21
3.4.8	Limits State Transitions	3-23
3.4.9	Disk Files	3-24
3.4.10	Related Variables	3-24
3.4.11	Related Events	3-24
3.5	Alarm Management	3-24
3.5.1	Alarm States	3-24
3.5.2	Reporting	3-25
3.5.3	Enable/Disable	3-25
3.5.4	Host Requests Alarm Status	3-25
3.5.5	Compatibility	3-25

3.5.6	Related Variables	3-26
3.5.7	Related Collection Events	3-26
3.6	Process Program Management.....	3-27
3.6.1	Equipment Management of Process Programs	3-27
3.6.2	Host Management of Process Programs	3-27
3.6.3	Related Variables	3-28
3.6.4	Related Events	3-28
3.7	Remote Commands.....	3-29
3.7.1	S2F41 Commands.....	3-30
3.7.2	Related Variables	3-32
3.7.3	Related Events	3-32
3.8	Material Movement	3-33
3.8.1	Related Variables	3-33
3.8.2	Related Collection Events	3-33
3.9	Equipment Terminal Services.....	3-34
3.10	Error Messages	3-35
3.11	Clock.....	3-35
3.11.1	Related Variables	3-35
3.12	Spooling.....	3-36
3.12.1	A Word of Caution	3-36
3.12.2	Spooling Sequence	3-37
3.12.3	Spool States	3-41
3.12.4	Related Variables	3-42
3.12.5	Related Events	3-42
4	SECS MESSAGE DETAIL	4-1
4.1	SML Notation.....	4-1
4.1.1	Data Item Format.....	4-1
4.1.2	Message Format.....	4-3
4.2	SECS Messages	4-4
4.2.1	S1F1 - Are You There	4-4
4.2.2	S1F2 - On Line Data (Equipment to Host)	4-4
4.2.3	S1F2 - On Line Data (Host to Equipment)	4-4
4.2.4	S1F3 - Selected Status Request.....	4-5
4.2.5	S1F4 - Selected Status Data.....	4-5
4.2.6	S1F11 - Status Variable Namelist Request.....	4-6
4.2.7	S1F12 - Status Variable Namelist Reply	4-6
4.2.8	S1F13 - Connect Request.....	4-7

4.2.9	S1F14 - Connect Request Acknowledge	4-7
4.2.10	S1F15 - Request Off-Line	4-8
4.2.11	S1F16 - Off-Line Acknowledge	4-8
4.2.12	S1F17 - Request On-Line	4-8
4.2.13	S1F18 - On-Line Acknowledge	4-8
4.2.14	S1F65 - Connect Request.....	4-9
4.2.15	S1F66 - Connect Request Acknowledge	4-10
4.2.16	S2F13 - Equipment Constant Request	4-11
4.2.17	S2F14 - Equipment Constant Data	4-11
4.2.18	S2F15 - New Equipment Constant Send	4-12
4.2.19	S2F16 - Equipment Constant Send Acknowledge	4-12
4.2.20	S2F17 - Date and Time Request.....	4-13
4.2.21	S2F18 - Date and Time Data	4-13
4.2.22	S2F23 - Trace Initialize Send	4-14
4.2.23	S2F24 - Trace Initialize Acknowledge	4-15
4.2.24	S2F25 - Diagnostic Loopback Request.....	4-16
4.2.25	S2F26 - Diagnostic Loopback Data	4-16
4.2.26	S2F27 - Initiate Process Request.....	4-16
4.2.27	S2F28 - Initiate Process Acknowledge	4-17
4.2.28	S2F29 - Equipment Constant Namelist Request	4-17
4.2.29	S2F30 - Equipment Constant Namelist Reply.....	4-18
4.2.30	S2F31 - Date and Time Send.....	4-18
4.2.31	S2F32 - Date and Time Acknowledge	4-18
4.2.32	S2F33 - Define Report	4-19
4.2.33	S2F34 - Define Report Acknowledge	4-20
4.2.34	S2F35 - Link Event Report	4-21
4.2.35	S2F36 - Link Event Report Acknowledge	4-22
4.2.36	S2F37 - Enable/Disable Event Report	4-23
4.2.37	S2F38 - Enable/Disable Event Report Acknowledge.....	4-23
4.2.38	S2F39 - Multi-Block Inquire	4-24
4.2.39	S2F40 - Multi-Block Grant	4-24
4.2.40	S2F41 - Remote Command with Parameters	4-25
4.2.41	S2F42 - Remote Command Acknowledge.....	4-26
4.2.42	S2F43 - Reset Spooling Streams and Functions	4-28
4.2.43	S2F44 - Reset Spooling Acknowledge.....	4-29
4.2.44	S2F45 - Define Variable Limits Attributes	4-30
4.2.45	S2F46 - Variable Limit Attribute Acknowledge.....	4-32
4.2.46	S2F47 - Variable Limit Attribute Request.....	4-34

4.2.47	S2F48 - Variable Limit Attributes Send	4-35
4.2.48	S5F1 - Alarm Report.....	4-36
4.2.49	S5F2 - Alarm Acknowledge	4-37
4.2.50	S5F3 - Enable/Disable Alarm Send.....	4-37
4.2.51	S5F4 - Enable/Disable Alarm Acknowledge	4-38
4.2.52	S5F5 - List Alarms Request	4-38
4.2.53	S5F6 - List Alarm Data	4-38
4.2.54	S5F7 - List Enabled Alarms Request	4-39
4.2.55	S5F8 - List Enabled Alarm Data	4-39
4.2.56	S5F71 - Alarm Report Block Send	4-40
4.2.57	S5F72 - Alarm Report Block Acknowledge	4-41
4.2.58	S5F73 - Alarm Report Block Acknowledge	4-41
4.2.59	S5F74 - Alarm Notification Acknowledge	4-41
4.2.60	S6F1 - Trace Data Send	4-42
4.2.61	S6F2 - Trace Data Acknowledge	4-42
4.2.62	S6F3 - Annotated Event Report	4-43
4.2.63	S6F4 - Annotated Event Report Acknowledge.....	4-44
4.2.64	S6F5 - Multi-Block Data Send Inquire	4-44
4.2.65	S6F6 - Multi-Block Grant	4-44
4.2.66	S6F9 - Event Report.....	4-45
4.2.67	S6F10 - Event Report Acknowledge	4-46
4.2.68	S6F11 - Event Report Send	4-46
4.2.69	S6F12 - Event Report Acknowledge	4-47
4.2.70	S6F13 - Annotated Event Report Send.....	4-47
4.2.71	S6F14 - Annotated Event Report Acknowledge.....	4-48
4.2.72	S6F15 - Event Report Request	4-48
4.2.73	S6F16 - Event Report Data	4-49
4.2.74	S6F17 - Annotated Event Report Request.....	4-50
4.2.75	S6F18 - Annotated Event Report Data.....	4-50
4.2.76	S6F19 - Request Report Request.....	4-51
4.2.77	S6F20 - Request Report Data	4-51
4.2.78	S6F21 - Request Annotated Report Request	4-51
4.2.79	S6F22 - Request Annotated Report Data	4-52
4.2.80	S6F23 - Request Spooled Data	4-52
4.2.81	S6F24 - Request Spooled Data Acknowledge.....	4-53
4.2.82	S7F1 - Process Program Load Inquire.....	4-53
4.2.83	S7F2 - Process Program Load Grant.....	4-54
4.2.84	S7F3 - Process Program Send	4-55

4.2.85	S7F4 - Process Program Acknowledge	4-55
4.2.86	S7F5 - Process Program Request	4-56
4.2.87	S7F6 - Process Program Data	4-56
4.2.88	S7F17 - Process Program Delete	4-57
4.2.89	S7F18 - Process Program Delete Acknowledge.....	4-57
4.2.90	S7F19 - Process Program Directory Request.....	4-58
4.2.91	S7F20 - Process Program Directory	4-58
4.2.92	S9F1 - Unrecognized Device ID.....	4-58
4.2.93	S9F3 - Unrecognized Stream.....	4-58
4.2.94	S9F5 - Unrecognized Function.....	4-58
4.2.95	S9F7 Invalid Data	4-59
4.2.96	S9F9 Transaction Timer Timeout.....	4-59
4.2.97	S9F11 - Data Too Long.....	4-59
4.2.98	S10F1 - Terminal Request	4-59
4.2.99	S10F2 - Terminal Request Acknowledge.....	4-60
4.2.100	S10F3 - Terminal Display, Single.....	4-60
4.2.101	S10F4 - Terminal Display Single Acknowledge	4-61
4.2.102	S10F5 - Terminal Display, Multiblock.....	4-61
4.2.103	S10F6 - Terminal Display Multiblock Acknowledge	4-62
4.2.104	S10F9 - Broadcast.....	4-62
4.2.105	S10F10 - Broadcast Acknowledge.....	4-62

5 SECS SCENARIOS..... 5-1

5.1	Equipment Communications.....	5-1
5.1.1	Equipment Establishes Communications.....	5-1
5.1.2	Host Establishes Communications.....	5-2
5.1.3	Simultaneous Establish Communications	5-2
5.1.4	Losing Connection, Re-Connecting	5-3
5.1.5	Heartbeat.....	5-3
5.2	Data Collection	5-4
5.2.1	Host Initializes Event Reporting	5-4
5.2.2	Equipment Reports Event	5-5
5.2.3	Equipment Reports Annotated Event.....	5-5
5.2.4	Host Initiates Trace.....	5-6
5.2.5	Host Terminates Trace.....	5-6
5.2.6	Host Requests Status.....	5-7
5.2.7	Host Defines Limits.....	5-7
5.2.8	Host Queries Defined Limits.....	5-7
5.2.9	Host Requests Report by CEID.....	5-7

5.2.10	Host Requests Annotated Report by CEID	5-8
5.2.11	Host Requests Report by RPTID	5-8
5.2.12	Host Requests Annotated Report by RPTID	5-8
5.2.13	Are You There	5-9
5.2.14	Host Reads Equipment Constants	5-9
5.2.15	Host Sets Equipment Constants	5-9
5.3	Alarms	5-10
5.3.1	Equipment Reports Alarm	5-10
5.3.2	Host Enables/Disables Alarms	5-10
5.3.3	Host Requests Alarms.....	5-10
5.3.4	Alarm Report (GEM, Ver 3.1 Compatibility)	5-11
5.3.5	Alarm Report (GEM, Ver 1.7 Compatibility)	5-12
5.4	Control State.....	5-13
5.4.1	Host Sends On-Line Command	5-13
5.4.2	Host Sends Off-Line Command	5-13
5.4.3	Host Sends Remote Command.....	5-14
5.4.4	Equipment Rejects Host Command	5-14
5.4.5	Go Remote, Operator-Initiated	5-14
5.4.6	Go Local, Operator-Initiated	5-15
5.4.7	Go Local, Host-Initiated	5-15
5.4.8	Operator Command, Successful	5-15
5.5	Process Program Management.....	5-16
5.5.1	Unformatted, Host-Initiated Download	5-16
5.5.2	Unformatted, Host-Initiated Upload	5-16
5.5.3	Unformatted, Equipment-Initiated Download	5-17
5.5.4	Unformatted, Equipment-Initiated Upload	5-17
5.5.5	Host Deletes Process Program	5-18
5.5.6	Host Requests Directory	5-18
5.5.7	Operator Changes Process Program Library.....	5-18
5.6	Equipment Terminal Communications.....	5-19
5.6.1	Host to Equipment, Single Line	5-19
5.6.2	Host to Equipment, Multi-Line	5-19
5.6.3	Equipment Sends Text to Host.....	5-20
5.7	SECS Error Messages	5-20
5.7.1	Unrecognized Device ID.....	5-20
5.7.2	Unrecognized Stream.....	5-20
5.7.3	Unrecognized Function	5-21

5.7.4	Illegal Data Format	5-21
5.7.5	Data Too Long.....	5-21
5.8	Clock.....	5-22
5.8.1	Host Sets Date and Time	5-22
5.8.2	Host Requests Date and Time	5-22
5.8.3	Equipment Requests Date and Time	5-22
5.9	Spooling.....	5-23
5.9.1	Host Enables Spooling of Messages	5-23
5.9.2	Messages Spooled and Transmitted.....	5-24
5.9.3	Host Purges Spool.....	5-25
6	MACHINE VARIABLE DEFINITIONS	6-1
6.1	Status Variables	6-1
6.2	Data Variables.....	6-4
6.3	Equipment Constants	6-8
7	HOST-TO-EQUIPMENT MESSAGES	7-1
8	EQUIPMENT-TO-HOST MESSAGES	8-1
	APPENDIX A – DATA DICTIONARY VARIABLES.....	A-1
	APPENDIX B – COLLECTION EVENTS.....	B-1
	APPENDIX C – ALARMS	C-1
	GLOSSARY	G-1

Table of Figures

Figure 1-1	Terminal Message Notification (FmXP shown)	1-18
Figure 1-2	SECS/GEM Setup Dialog Box – Control Tab (FmXP shown)	1-19
Figure 1-3	SECS/GEM Setup Dialog Box – Terminal Tab (FmXP shown).....	1-20
Figure 1-4	SECS/GEM Setup Dialog Box – Setup Tab (FmXP shown).....	1-21
Figure 1-5	SECS/GEM Setup Dialog Box – Communication Tab (FmXP shown)	1-22
Figure 1-6	SECS/GEM Setup Dialog Box – Version Tab (FmXP shown).....	1-22
Figure 1-7	Run Window – SECS/GEM Tab (FmXP shown)	1-23
Figure 3-1	Communication Finite State Diagram.....	3-2
Figure 3-2	Equipment Control State Diagram.....	3-7
Figure 3-3	E10 State Diagram	3-13
Figure 3-4	Equipment Process States	3-16
Figure 3-5	Limits Events Signaling	3-21
Figure 3-6	Limits State Diagram	3-22
Figure 3-7	Spooling State Diagram.....	3-37

Table of Tables

Table 1-1	Definition of Terms.....	1-2
Table 1-2	RS-232 Pins.....	1-5
Table 1-3	GEM Compliance Statement	1-9
Table 1-4	SECS Installation Parameters	1-11
Table 1-5	GemRPTYPE	1-12
Table 1-6	Compatibility Settings	1-13
Table 1-7	Remote Run Commands	1-17
Table 2-1	SECS Messages – Host-to-Equipment.....	2-1
Table 2-2	Control State Values.....	2-2
Table 2-3	SECS Messages – Equipment-to-Host.....	2-3
Table 3-1	State Transitions.....	3-3
Table 3-2	Communication State Values	3-4
Table 3-3	Related Variables	3-5
Table 3-4	Control States	3-6
Table 3-5	Control State Transitions	3-8
Table 3-6	Control State Values.....	3-10

Table 3-7	Control State Variables	3-11
Table 3-8	Control State CEIDS	3-12
Table 3-9	E10 State Transitions	3-14
Table 3-10	E10 State Values	3-15
Table 3-11	Process State Transitions	3-17
Table 3-12	Equipment Process State Values	3-18
Table 3-13	Equipment Processing Variables	3-18
Table 3-14	Limits State Transitions	3-23
Table 3-15	Limits States	3-23
Table 3-16	Data Collection / Setup Variables	3-24
Table 3-17	Data Collection CEIDS	3-24
Table 3-18	Alarm Management Variables	3-26
Table 3-19	Process Program Management Variables	3-28
Table 3-20	Process Program Management CEIDS	3-28
Table 3-21	Remote Control Variable	3-32
Table 3-22	Remote Control CEIDS	3-32
Table 3-23	Clock Variables	3-35
Table 3-24	Spooling State Transitions	3-38
Table 3-25	Spooling Activity	3-39
Table 3-26	Power On Spool Substates	3-41
Table 3-27	Spooling Variables	3-42
Table 3-28	Spooling CEIDS	3-42
Table 4-1	Components of a SML Data Item	4-1
Table 4-2	Components SML Notation	4-3
Table 4-3	On-Line Acknowledge	4-8
Table 4-4	EAC Values	4-12
Table 4-5	Trace Initialize Acknowledge	4-15
Table 4-6	CMDA Values	4-17
Table 4-7	TIACK	4-18
Table 4-8	DRACK Values	4-20
Table 4-9	LRACK Values	4-22
Table 4-10	ERACK Values	4-23
Table 4-11	ERACK Values	4-25
Table 4-12	HACK Values	4-26
Table 4-13	CPACK Values	4-27

Table 4-14	RSPACK Values	4-29
Table 4-15	STRACK Values	4-30
Table 4-16	VLAACK Values.....	4-32
Table 4-17	LVACK Values	4-33
Table 4-18	VLACK Values	4-33
Table 4-19	ALED Values	4-37
Table 4-20	ACKC5 Values.....	4-38
Table 4-21	Multi-Block Event Values	4-44
Table 4-22	RSDC.....	4-52
Table 4-23	RSDA Values.....	4-53
Table 4-24	S7F2 PPGNT Values.....	4-54
Table 4-25	S7F2 PPGNT Interpretations.....	4-54
Table 4-26	S7F4 ACKC7 Values	4-55
Table 4-27	S7F4 ACKC7 Interpretations	4-56
Table 4-28	S7F18 ACKC7 Values	4-57
Table 4-29	S10F1 TID Values	4-59
Table 4-30	S10F2 ACKC10 Values	4-60
Table 4-31	S10F3 TID Values	4-60
Table 4-32	S10F4 ACKC10 Values	4-61
Table 4-33	S10F5 TID Values	4-61
Table 4-34	S10F6 ACKC10 Values	4-62
Table 4-35	S10F10 ACKC10 Values	4-62
Table 5-1	SECS Messages Equipment Establishes Communications	5-1
Table 5-2	SECS Messages Host Establishes Communications	5-2
Table 5-3	SECS Messages Simultaneous Establish Communications	5-2
Table 5-4	SECS Messages Losing Connection, Re-Connecting.....	5-3
Table 5-5	SECS Messages Heartbeat.....	5-3
Table 5-6	SECS Messages Host Initializes Event Reporting.....	5-4
Table 5-7	SECS Messages Equipment Reports Event.....	5-5
Table 5-8	SECS Messages Equipment Reports Annotated Event	5-5
Table 5-9	SECS Messages Host Initiates Trace.....	5-6
Table 5-10	SECS Messages Host Terminates Trace	5-6
Table 5-11	SECS Messages Host Requests Status.....	5-7
Table 5-12	SECS Messages Host Defines Limits.....	5-7
Table 5-13	SECS Messages Host Queries Defined Limits.....	5-7

Table 5-14	SECS Messages Host Requests Report by CEID	5-7
Table 5-15	SECS Messages Host Requests Annotated Report by CEID.....	5-8
Table 5-16	SECS Messages Host Requests Report by RPTID.....	5-8
Table 5-17	SECS Messages Host Requests Annotated Report by RPTID	5-8
Table 5-18	SECS Messages Are You There	5-9
Table 5-19	SECS Messages Host Reads Equipment Constants	5-9
Table 5-20	SECS Messages Host Sets Equipment Constants.....	5-9
Table 5-21	SECS Messages Equipment Reports Alarm	5-10
Table 5-22	SECS Messages Host Enables/Disables Alarms	5-10
Table 5-23	SECS Messages Host Requests Alarms.....	5-10
Table 5-24	SECS Messages Alarm Report (GEM, Ver 3.1 Compatibility).....	5-11
Table 5-25	SECS Messages Alarm Report (GEM, Ver 1.7 Compatibility).....	5-12
Table 5-26	SECS Messages Host Sends On-Line Command.....	5-13
Table 5-27	SECS Messages Host Sends Off-Line Command.....	5-13
Table 5-28	SECS Messages Host Sends Remote Command.....	5-14
Table 5-29	SECS Messages Equipment Rejects Host Command.....	5-14
Table 5-30	SECS Messages Go Remote, Operator-Initiated	5-14
Table 5-31	SECS Messages Go Local, Operator-Initiated	5-15
Table 5-32	SECS Messages Go Local, Host-Initiated	5-15
Table 5-33	SECS Messages Operator Command, Successful	5-15
Table 5-34	SECS Messages Unformatted, Host-Initiated Download.....	5-16
Table 5-35	SECS Messages Unformatted, Host-Initiated Upload	5-16
Table 5-36	SECS Messages Unformatted, Equipment-Initiated Download	5-17
Table 5-37	SECS Messages Unformatted, Equipment-Initiated Upload	5-17
Table 5-38	SECS Messages Host Deletes Process Program	5-18
Table 5-39	SECS Messages Host Requests Directory.....	5-18
Table 5-40	SECS Messages Operator Changes Process Program Library	5-18
Table 5-41	SECS Messages Host to Equipment, Single Line	5-19
Table 5-42	SECS Messages Host to Equipment, Multi-Line	5-19
Table 5-43	SECS Messages Equipment Sends Text to Host.....	5-20
Table 5-44	SECS Messages Unrecognized Device ID.....	5-20
Table 5-45	SECS Messages Unrecognized Stream.....	5-20
Table 5-46	SECS Messages Unrecognized Function.....	5-21
Table 5-47	SECS Messages Illegal Data Format	5-21
Table 5-48	SECS Messages Data Too Long.....	5-21
Table 5-49	SECS Messages Host Sets Date and Time	5-22

Table 5-50	SECS Messages Host Requests Date and Time	5-22
Table 5-51	SECS Messages Equipment Requests Date and Time.....	5-22
Table 5-52	SECS Messages Host Enables Spooling of Messages.....	5-23
Table 5-53	SECS Messages Spooled and Transmitted	5-24
Table 5-54	SECS Messages Host Purges Spool.....	5-25
Table 6-1	Status Variables.....	6-1
Table 6-2	Data Variables	6-4
Table 6-3	Equipment Constants	6-8
Table 7-1	Host-to-Equipment Messages	7-1
Table 8-1	Equipment-to-Host Messages	8-1
Table A-1	Data Dictionary Variables.....	A-1
Table B-1	CEID.....	B-1
Table C-1	Alarms	C-1

1 Introduction

1.1 Overview

This manual describes the SECS/GEM interface (version 4.8.3 or higher) used with Fluidmove for Windows NT (FmNT) version 4.8.3 or higher, or Fluidmove for Windows XP (FmXP) version 5.0 or higher. The term “Fluidmove” as used in this manual refers to the applicable software (FmNT or FmXP) used on the Equipment.

This document is a modification of the GW Associates GES-1993 SECS/GEM Interface document and has been especially prepared to support Fluidmove. The content and structure of this document follows the original GES-1993 document. User information and GEM interface with Fluidmove were added.

Fluidmove supports the GW Associates GEM subset of the SECS communication standard. Future references to the SECS/GEM interface will use only the GEM identification to acknowledge the specific approach used by Fluidmove.

The interface between Fluidmove and a Host computer is explained in detail. The interface conforms to the GEM standard. The GEM standard defines a standard implementation of the SECS-II communication interface for all semiconductor manufacturing equipment.

GW Associates (Software Model GEM-NT-100) is used to implement approximately 90% of SECS and GEM features, with Fluidmove implementing the remaining equipment-specific features.

1.2 Terminology

Abbreviations and terms used in this manual are defined in Table 1-1.

Table 1-1 Definition of Terms

Term	Definition
Alarm	An alarm is related to any abnormal situation on the Equipment. GEM allows the Host to be notified when alarm conditions are detected and cleared.
ALID	Equipment Alarm ID. The identifier for a specific alarm condition.
CEID	Collection Event ID. The identifier for a specific collection event.
Collection Event	A collection event is a detectable occurrence significant to the Equipment that is considered to be significant to the Host. GEM allows the Host to be notified when a collection event occurs. This allows the Host to track the Equipment's activity.
Data Variable (DV)	Data variables may only be valid upon the occurrence of a particular collection event. The Host may gather data variable values from the GEM Equipment.
Equipment	An intelligent system which communicates with a Host and complies with the GEM standard. In this manual it refers to the dispensing system.
Equipment Constant (EC)	Equipment Constants are settable by the Host. The Host may gather Equipment constant values from the GEM Equipment. The Host may also set Equipment constant values on the GEM Equipment to control the Equipment's behavior.
Fluidmove	The Fluidmove [®] for Windows NT [®] (FmNT) or Fluidmove [®] for Windows [®] XP (FmXP) software application which controls GEM.
GCD	GWGEM Configuration Data (an ASCII file compiled for GWGEM).
GEM	Generic Equipment Model. The GEM (E30) standard defines the generic behavior of semiconductor Equipment as viewed through a communications link in terms of SECS-II messages communicated over that link. The GEM standard impacts Equipment control and Equipment-to-Host communications.
High-Speed SECS Message Services (HSMS)	<p>HSMS (E37) is a high-speed replacement and an alternative to SECS-I for applications where higher speed communication is needed or where simple point-to-point technology is insufficient.</p> <p>HSMS defines a communication interface via TCP/IP suitable for the exchange of (SECS-II) messages between computers in a semiconductor factory.</p>
Host	The computer which is connected to, and communicates with, the Equipment via the SECS interface. The GEM standard defines a set of messages the Host must use when interacting with the Equipment. The Equipment communicates with one Host, but the Host may communicate with multiple Equipment units.
HSMS-GS	High Speed Message Service-General Session. This standard defines TCP/IP network communication used by GEM for Host/Equipment communication. It is intended to be applied for complex systems containing multiple independently accessible subsystems and uses an extended state machine.

Table 1-1 Definition of Terms (continued)

Term	Definition
HSMS-SS	High Speed Message Service-Single Session. This standard defines TCP/IP network communication used by GEM for Host/Equipment communication. It replaces the SECS-I standard.
ID	Identifier or Identification.
Operator	The person who physically has access to the Equipment's material port(s) and control panel. This is the person who is operating the dispensing system.
PP	Process Program
Recipe	A file containing a set of instructions for the Equipment.
Report	A set of variables predefined by the Equipment or defined by the Host. The Host uses reports to gather status variable, data variable, and Equipment constant values. The Host may request a report explicitly or attach a set of reports to a collection event.
SECS	<p>SEMI Equipment Communications Standard.</p> <p>SECS I (E4): SEMI Equipment Communications Standard 1 Message Transfer. Defines RS-232 serial communication used by GEM for Host/Equipment communication.</p> <p>SECS II (E5): SEMI Equipment Communications Standard 2 Message Content. A standard for communications between intelligent Equipment and a Host. The standard defines the communication protocol interface (SECS-I) and the messages exchanged (SECS-II).</p>
Message	All GEM Equipment and Host communication is accomplished using SECS-II messages. Each unique SECS-II message is identified by its stream number (S) and function number (F). The SECS-II standard defines a large set of SECS-II messages determining each one's purpose, content, and usage. The GEM standard defines how to use a subset of these SECS-II messages yet allows other SECS-II messages to be used in addition to this subset.
SEMI	Semiconductor Equipment and Materials International (SEMI) is a global trade association that represents the semiconductor and flat panel display equipment and materials industries. SEMI maintains and publishes standards that relate to Equipment automation and software.
Status Variable (SV)	Status Variable. Status variables may include any parameters that can be sampled in time such as temperature or quantity of a consumable. The Host may gather status variable values from the GEM Equipment.
UFPP	Unformatted Process Program
VID	Variable Identifier. A unique string representing the name of a variable.

1.3 SECS/GEM – Fluidmove Compatibility

Compatibility between Fluidmove and SECS/GEM version is as follows:

- FmNT 4.8 and earlier is compatible only with Fluidmove SECS/GEM, version 4.1.
- FmNT 4.8.2 and later, and FmXP 5.0 and later requires Fluidmove SECS/GEM, 4.8.1 or later.

1.4 SECS Standard

The SEMI Equipment Communication Standard (SECS) is published by Semiconductor Equipment and Materials International (SEMI). It defines a computer to computer communications interface between a unit of factory Equipment and a Host Computer.

This Equipment complies to the complete SECS-I standard (excluding the physical RS-232 hardware connection) and to the generic portions of the SECS-II standard. The Equipment implements an appropriate subset of the SECS-II standard messages and complies with the following versions of standards:

- E4-1991 (SECS-I)
- E5-1993 (SECS-II)



NOTES There were no changes to the SEMI E4 standard for 1993.

GWGEM Software is used to meet the SECS standard.

SECS default parameters will be used wherever possible; differences will be noted.

1.4.1 SECS-I Clarifications

The Equipment was designed to avoid using any of the unusual features of the SECS standard, so as to simplify the job of implementing Equipment support on the Host. This section clarifies the Equipment/Host SECS interface.

Fluidmove supports only Ethernet High Speed SECS Message Services (HSMS) in conjunction with communication drivers supplied by GW Associates.

Fluidmove does not support RS-232 interfaces.

1.4.2 Physical Connection

The GEM hardware interface must be a TCP/IP network card connection through a Ten-Base-T connector or BNC jack (SECS-II interface).

 **NOTE** The following information is provided only as a reference for RS-232 connections (SECS-I interface) and is currently not implemented by Fluidmove:

- The RS-232 connector on the Equipment deviates from the standard SECS-I DB25F connector.
- The Equipment provides a male 25-pin RS-232 “DB25M” connector on its back panel as the SECS port. Table 1-2 lists the pins used on the RS-232 connector.

Table 1-2 RS-232 Pins

Pin No.	Description
1	Shield.
2	TX Data (Equipment-to-Host).
3	RX Data (Host-to-Equipment).
4	Request to send (RTS). The Equipment raises this output signal when activating SECS. Not required by SECS standard, but you may find it useful for modem control.
7	Signal Ground.
20	Data Terminal Ready (DTR). The Equipment raises this output signal when activating SECS. This is not required by the SECS standard, but you may find it useful for modem control.

Note: Optional SECS power pins 18 and 25 are not provided.

1.4.3 SECS-I Blocks Transmitted

The Equipment uses the following SECS-I conventions in the blocks it sends:

- The Device ID is present in every block, with the R-bit always set to “1”.
- The Block Number is always one (0x0001) for the first block of a message.
- For Primary messages, the System Bytes are generated unique for each message. For Secondary messages, the System Bytes are replicated from the received Primary message.
- SECS-I Blocks Received

Blocks received by the Equipment should be formatted as described above (except with the R-bit set to “0”), although the rules are more relaxed:

If a message consists of a single block, the Block Number may be zero (0x0000) or one (0x0001).

The Equipment is indifferent to the R-bit setting.

1.4.4 Interleaved Blocks

The Equipment never sends interleaved blocks to the Host. That is, the Equipment always sends all blocks of one message before sending the first block of the next message. This simplifies the job of the Host.

However, the Equipment allows the Host to send interleaved blocks, if it so chooses.

1.4.5 Simultaneous Transactions

The Equipment may initiate several simultaneous outstanding SECS transactions. That is, the Equipment may send a secondary primary message before the Host has sent the Reply to a previous primary message. Mainly, this occurs when the Equipment reports Alarms and Events. The Host can reduce the number of outstanding transactions initiated by the Equipment by setting equipment constants appropriately so that the Equipment sends no W-Bit for Stream 5 (Alarm), Stream 6 (Event), and Stream 10 (Free Text) messages.

The Equipment allows the Host to initiate at least two (2) simultaneous outstanding transactions.

1.5 SECS-II Clarifications

The Equipment uses the following SECS-II conventions:

1.5.1 Data Format Types

Where the Standards permit a choice of data item types, the choice has been made as described in [Section 4 SECS Message Detail](#).

For outgoing messages, the Equipment always sends Data Items of the exact format shown. For some incoming messages, the Equipment “forgives” minor Host errors. For example, the Equipment may accept a U1 Data Item where a U2 format was expected. We recommend the Host attempt to use the formats shown.

1.5.2 Data Item Length Bytes

For messages sent by the Equipment, the number of length bytes in Data Items is always the minimum required to contain the Data Item length.

For messages received from the Host, the number of length bytes in Data Items can be 1, 2, or 3, provided that the length parameter can accurately be specified.

1.5.3 ASCII Data

Unless otherwise specified, all ASCII data items must contain printable ASCII data—that is, characters in the range 0x20 to 0x7E.

1.5.4 Multi-Block Messages

Wherever the Host is supposed to send a single-block message, this Equipment will also accept multi-block format.

The maximum size for a single SECS message is approximately 1000 blocks (256,000 bytes).

1.5.5 Function Zero

The Equipment sends a Reply message using Function zero (F0) according to the requirements of the GEM Control State.

Wherever this Equipment expects a Reply message from the Host, the Host can send F0. The Equipment will instantly abort the outstanding transaction. The Equipment will not take any additional action.

1.6 GEM Standard

The SEMI Generic Equipment Model for Effective Factory Automation (GEM) is another document published by SEMI. The GEM standard defines some useful conventions for designing the communications interface on a unit of factory Equipment to improve operations with a Host Computer. The Equipment complies with SEMI E30-1993.

1.7 GEM Compliance

The following items and Table 1-3 clarify which GEM functions are implemented in this Equipment:

- The Equipment never sends S2F25 (Loopback Diagnostic) to the Host. It will send the appropriate S2F26 in response to an S2F25 from the Host.
- The Equipment never sends S9F13 (Conversation Timeout) to the Host. The Equipment can be defined as having an “infinite timeout” for conversations.
- The Equipment never sends S10F7 (Multi-Block Not Allowed) to the Host. It will accept incoming messages consisting of printable characters and a maximum size of 320 characters.
- The Equipment will accept, but does not require, the Inquire/Grant transaction (S2F39/S2F40, S6F5/S6F6, S7F1/S7F2) for incoming primary multi-block messages.
- GWGEM Software Model GEM-NT-100 is used by Fluidmove to meet the SECS standard.

Table 1-3 GEM Compliance Statement

FUNDAMENTAL GEM REQUIREMENTS	IMPLEMENTED	COMPLIANT
State Models	<input checked="" type="checkbox"/> Yes <input type="checkbox"/> No	<input checked="" type="checkbox"/> Yes <input type="checkbox"/> No
Equipment Processing States	<input checked="" type="checkbox"/> Yes <input type="checkbox"/> No	<input checked="" type="checkbox"/> Yes <input type="checkbox"/> No
S1F13/S1F14 Auto Connection Scenario	<input checked="" type="checkbox"/> Yes <input type="checkbox"/> No	<input checked="" type="checkbox"/> Yes <input type="checkbox"/> No
Event Notification	<input checked="" type="checkbox"/> Yes <input type="checkbox"/> No	<input checked="" type="checkbox"/> Yes <input type="checkbox"/> No
On-line Identification	<input checked="" type="checkbox"/> Yes <input type="checkbox"/> No	<input checked="" type="checkbox"/> Yes <input type="checkbox"/> No
Error Messages	<input checked="" type="checkbox"/> Yes <input type="checkbox"/> No	<input checked="" type="checkbox"/> Yes <input type="checkbox"/> No
Control (Operator Initiated)	<input checked="" type="checkbox"/> Yes <input type="checkbox"/> No	<input checked="" type="checkbox"/> Yes <input type="checkbox"/> No
Documentation	<input checked="" type="checkbox"/> Yes <input type="checkbox"/> No	<input checked="" type="checkbox"/> Yes <input type="checkbox"/> No
ADDITIONAL CAPABILITIES	IMPLEMENTED	COMPLIANT
Establish Communications	<input checked="" type="checkbox"/> Yes <input type="checkbox"/> No	<input checked="" type="checkbox"/> Yes <input type="checkbox"/> No
Dynamic Event Report Configuration	<input checked="" type="checkbox"/> Yes <input type="checkbox"/> No	<input checked="" type="checkbox"/> Yes <input type="checkbox"/> No
Variable Data Collection	<input checked="" type="checkbox"/> Yes <input type="checkbox"/> No	<input checked="" type="checkbox"/> Yes <input type="checkbox"/> No
Trace Data Collection	<input checked="" type="checkbox"/> Yes <input type="checkbox"/> No	<input checked="" type="checkbox"/> Yes <input type="checkbox"/> No
Status Data Collection	<input checked="" type="checkbox"/> Yes <input type="checkbox"/> No	<input checked="" type="checkbox"/> Yes <input type="checkbox"/> No
Alarm Management	<input checked="" type="checkbox"/> Yes <input type="checkbox"/> No	<input checked="" type="checkbox"/> Yes <input type="checkbox"/> No
Remote Control	<input checked="" type="checkbox"/> Yes <input type="checkbox"/> No	<input checked="" type="checkbox"/> Yes <input type="checkbox"/> No
Equipment Constants	<input checked="" type="checkbox"/> Yes <input type="checkbox"/> No	<input checked="" type="checkbox"/> Yes <input type="checkbox"/> No
Process Program Management	<input checked="" type="checkbox"/> Yes <input type="checkbox"/> No	<input checked="" type="checkbox"/> Yes <input type="checkbox"/> No
Material Movement	<input checked="" type="checkbox"/> Yes <input type="checkbox"/> No	<input checked="" type="checkbox"/> Yes <input type="checkbox"/> No
Equipment Terminal Services	<input checked="" type="checkbox"/> Yes <input type="checkbox"/> No	<input checked="" type="checkbox"/> Yes <input type="checkbox"/> No
Clock	<input checked="" type="checkbox"/> Yes <input type="checkbox"/> No	<input checked="" type="checkbox"/> Yes <input type="checkbox"/> No
Limits Monitoring	<input checked="" type="checkbox"/> Yes <input type="checkbox"/> No	<input checked="" type="checkbox"/> Yes <input type="checkbox"/> No
Spooling	<input checked="" type="checkbox"/> Yes <input type="checkbox"/> No	<input checked="" type="checkbox"/> Yes <input type="checkbox"/> No
Control (Host Initiated)	<input checked="" type="checkbox"/> Yes <input type="checkbox"/> No	<input checked="" type="checkbox"/> Yes <input type="checkbox"/> No

1.8 SEMI E10 Standard



NOTE Fluidmove does not upload the E10 states through the SECS/GEM interface.

SEMI E10 provides a guideline for the definition and measurement of Equipment reliability, availability, and maintainability (RAM). This document defines six basic Equipment States which define how Equipment time is categorized.

A status bar on the Equipment reflects the current E10 state. These Equipment states are as defined in SEMI E10-1992 (Section 3, 'Equipment States').

1.9 SECS I / SECS II Parameters

1.9.1 SECS-I Parameters

This section provides hardware settings that apply only to the RS-232 hardware interface.



NOTE Fluidmove currently does not support this interface.

Table 1-4 SECS Installation Parameters

Parameter	Default	Description
Device ID	1	Specified as a value from 0 to 32767 (15 bits).
Baud Rate	9600	Allowable speeds are 110, 150, 300, 600, 1200, 2400, 4800, 9600, and 19200 Baud.
T1	0.5 Sec	Inter-character Timeout. Range allowed is 0.1 to 10.0 seconds, at increments of 0.1 seconds.
T2	10.0 Sec	Protocol Timeout. Range allowed is 0.2 to 25.0 seconds, at increments of 0.1 seconds.
T3	45 Sec	Transaction Timeout. Range allowed is 1 to 120 seconds, at increments of 1 second.
T4	45 Sec	Inter-Block Timeout. Range allowed is 1 to 120 seconds, at increments of 1.
RTY	3	Transmit Failure Retry Limit. Range allowed is 0 to 31, at increments of 1.
DUPLIC	Off	Duplicate Block Detect. May be Enabled (On) or Disabled (Off).

1.9.2 SECS-II Parameters

This section applies only to the Ethernet hardware interface defined in the SECS II standard.

There are no Operator adjustable parameters involved in configuring the SECS II interface.



The operating system of the Equipment computer must be made aware of the network connection or the SECS/GEM feature will not operate.

1.9.3 GEM Configuration

This Equipment is configurable for operation with most older Host computers which do not support the GEM message set, or support an older version of GEM.

1. Equipment constant “CONFIGALARMS” (VID 1) selects the message the Equipment will send for Alarm Reports. “ConfigAlarms” may be 0, 1, or 2, selection S5F1, S5F71, or S5F73, respectively.
2. Equipment constant “CONFIGCONNECT” (VID 2) selects the message the Equipment will send for Connect Request. “ConfigConnect” may be 0, 1, or 2, selecting S1F1, S1F65, or S1F13, respectively.
3. Equipment constant “CONFIGEVENTS” (VID 3) selects which message the Equipment will send for Event Reports. If “ConfigEvents” is 0, the Equipment will send S6F9 for normal (unannotated) Event Reports or S6F3 for annotated Event Reports. If “ConfigEvents” is 1, the Equipment will send S6F11 for normal Event Reports or S6F13 for annotated Event Reports.
4. Equipment constant “RPTYPE” (VID 17) selects whether the Equipment will send “normal” Event Reports (S6F9 or S6F11) or annotated Event Reports (S6F3 or S6F13).

RpType = “False”. Equipment will send “normal” Event Reports.

RpType = “True”. Equipment will send annotated Event Reports.

Table 1-5 GemRPTYPE

	GemConfigEvents = 0	GemConfigEvents = 1
GemRPTYPE = FALSE	S6F9	S6F11
GemRPTYPE = TRUE	S6F3	S6F13

5. For a non-GEM Host, build appropriate Report Definitions, Links, and Enables (S2F33, S2F35, S2F37) so that S6F9 or S6F3 Event Reports contain the desired data.
6. Equipment constant “WBITS5” (VID 19) selects whether Stream 5 primary message (S5F1, S5F71, and S5F73) sent by the Equipment will have the W-bit set to “0” or “1”.
7. Equipment constant “WBITS6” (VID 20) selects whether Stream 6 primary messages (S6F1, S6F3, S6F9, S6F11, and S6F13) sent by the Equipment will have the W-bit set to “0” or “1”.
8. Equipment constant “WBITS10” (VID 18) selects whether Stream 10 primary message S10F1 sent by the Equipment will have the W-bit set to “0” or “1”.
9. Equipment constant “CONFIGSPOOL” (VID 63) configures whether the Equipment will transition to “Spool Active” state when a RTY error occurs.

Table 1-6 shows the recommended settings for compatibility with various types of Hosts. Factory (Default) settings are shown in bold.

Table 1-6 Compatibility Settings

Equipment Constant	E30-93	GEM 3.1	GEM 3.0	GEM 2.0	GEM 1.7	Non-GEM
CONFIGALARMS	0	2	2	2	1	0
CONFIGCONNECT	2	2	2	1	1	0
CONFIGEVENTS	1	1	1	1	1	0
RPTYPE	False	False	False	False	False	False or True
WBITS5	1	1 or 0	1 or 0	1 or 0	1 or 0	1 or 0
WBITS6	1	1	1	1	1	1 or 0
WBITS10	1	1 or 0	1 or 0	1 or 0	1 or 0	0
CONFIGSPOOL	1	0	0	0	0	0

1.10 State Diagrams

This document uses several Finite State Machine diagrams to describe the current condition of the Equipment's SECS link, material handling mechanisms, and process cycle. Each Finite State Machine diagram includes a State Diagram and a complete description of the states and state transitions.

All Finite State Diagrams have been prepared in the format specified in the GEM standard. This notation is required as a fundamental part of GEM compliance and must be included in the Equipment SECS Interface Documentation. This notation is the "Statechart" notation developed by David Harel.

The following are the major characteristics of this notation as it is used in this document:

1. Each state is represented by a rectangle with rounded corners.
2. A collection of sub-states may be grouped into a super-state.
3. The entity described by the diagrams will be in one and only one of the sub-states at all times.
4. Variables representing the current state of an entity do not contain values for super-states, only the lowest sub-state is represented.
5. State transitions are represented by single-headed arrows.
6. Each state transition is a Collection Event, and it has a unique Collection Event ID (CEID).
7. An arrow directly from a super-state to another state describes a Collection Event that can occur while the entity is in any one of the sub-states contained in the super-state.
8. An arrow directly into a super-state to the H* (history) symbol describes a transition to the lowest sub-state which described the entity just before the transition out of the super-state.
9. An arrow directly into a super-state to the C (conditional) symbol describes a transition to a particular sub-state based on some other relevant data. The conditional data is not represented in the diagram but is described in the associated text.

1.11 Machine Operation and the GEM Interface

1.11.1 Connecting to the Host

Fluidmove loads the GEM communications driver immediately upon startup. Once connection to the driver is established, the device enters its default communication state as set by the Operator. This default state can be set via the SECS/GEM Setup dialog box in Fluidmove. The recommended selection is “Enabled”. If enabled, the Communications State Machine in the GEM driver sends the Establish Communications Request message (S1F13) every ESTABLISHCOMMUNICATIONSTIMER seconds until a reply is received from the Host. The Communication State changes to reflect this response.

Unlike other state machines, transitions in this state machine do not produce events or message reports to the Host.

In the Main Window of Fluidmove, the GEM Status control can be seen in the lower part of the screen in a status bar display format. The COMM section displays the GEM communication state of the program. The CTRL section displays the control state of the program. The SPOOL section displays the spooling state of the program. General GEM controls are available to the user by clicking on the SECS/GEM button from the main window.

The initial (default) control state is set through Fluidmove’s SECS/GEM Setup dialog box. “ONLINE/REMOTE” is recommended for this setting. This way, the Host has control of the machine once the application has started and communication has been established. Refer to [1.11.7 SECS/GEM Setup Dialog Box in Fluidmove](#) for further details.

Normally, communications are established without fault, and going to the GEM setup dialog would only be used by the Operator to manually go off line for maintenance reasons.

1.11.2 Device Identification

The Host periodically sends the Are You There message (S1F1) to the Equipment. If the communication link is operational the Equipment automatically responds with the acknowledgment message (S1F2) which contains Fluidmove model type (MDLN) and software revision number (SOFTREV). The Host may receive more detailed information by requesting the MachineID variable from the Equipment.

1.11.3 Clock

The Host updates the GEM TIME structure periodically using the Date and Time Send message (S2F31). Fluidmove will update its system clock to reflect the data presented by the Host. Current values of the system time are used extensively in event logging and will be required to synchronize with comparable events logged by the Host.

1.11.4 Loss of Communications Link: Spooling

Communications may be temporarily lost with the Host from time to time. GEM message responses and requests are automatically spooled to disk when this happens. When communications are restored the messages on the SPOOL file are automatically sent to the Host.

Spooling is enabled for Fluidmove. The Host may query the SPOOLSTSATE and CONTROLSTATE variables with the Selected Equipment Status Request message (S1F3) in order to establish the success of REMOTE operations. In addition, the Host will receive spooling update messages from Fluidmove.

The default spool state can be set through the Fluidmove SECS/GEM Setup dialog box.

1.11.5 Communications Error Messages

Occasionally messages are garbled between Fluidmove and the Host. Garbled message device IDs and streams result in Fluidmove replying to the Host with S9F1 and S9F3 messages. Further distortion of the message results in the device ignoring the message which causes the Host to resend the message. See [4.2.92 S9F1 – Unrecognized Device ID](#) and [4.2.93 S9F3 – Unrecognized Stream](#) for details of the message exchange.

1.11.6 Normal Communications

1.11.6.1 Alarm Notification

Alarms are reports of errors (caused by the program or the operator) or events which may result in production or Equipment damage or events which may cause a safety hazard to workers. When an alarm state occurs, Fluidmove initiates an alarm notification (message S5F1) to the Host. The Process State transfers into the Alarm-Paused state and the Equipment stops dispensing and retracts the dispenser apparatus from the board.

The Operator will need to correct the alarm condition and guide the machine through the Paused state to the Idle State.

The Host may poll the Equipment to receive lists of enabled or existing alarms. When the Host sends a List Alarm Data message (S5F6) the Equipment replies with a list of the current active alarms. The Host may receive a list of the currently enabled alarms with the List Enabled Alarms Request (S5F7).

1.11.6.2 Remote Control Operations

Both the Host and the Operator are allowed to request runtime control of Fluidmove from each other. When the control state is Local, only the Operator has the ability to command Fluidmove, and Host run commands are rejected. Conversely, when the Host has control of Fluidmove, the Operator is limited to requesting Fluidmove status displays and Help screens. The Operator can stop, abort, or pause the process from the Run Window. Host will receive an event if the Operator presses any of the buttons from the Run Window. Refer to [Appendix B](#) for the list of these events.

Both the Host and the Operator may request that control be turned over to the requester. Each change in the control state machine generates a notification event to the Host.

Remote run commands are described in Table 1-7.

Table 1-7 Remote Run Commands

Command	Description
START	This command is successful when the Control State is OnLine - REMOTE , the board is in the Dispensing position, the machine is configured for a run, and the process program has been selected. This event begins the continuous processing of substrate trays. Processing can be interrupted by STOP, PAUSE, and ABORT commands. The Operator can also initiate PAUSE and STOP commands from the Run Window.
STOP	This command is successful when the Control State is OnLine - REMOTE, and the Process State is Running. It causes a halt in dispensing following completion of the current substrate cycle. The Process State changes to IDLE when this command is delivered and the process program is terminated. Further processing of the substrate tray is not possible after completing this command.
PAUSE	This command is successful when the Control State is OnLine - REMOTE and the Process State is Running. It causes a halt in dispensing following completion of the current instruction. The board and the process program are retained without change. The Process State changes to PAUSED. Diagnostics and status checks may be performed at this time. The substrate processing may be continued in the Running State by delivering the RESUME command.
RESUME	This command is successful when the Control State is OnLine - REMOTE, and the Process State is PAUSED. Processing of the substrate tray continues exactly from the PAUSED point and the current process program executes from the beginning of the next unprocessed instruction.
LOCAL	This command is successful if the current Control State is OnLine -REMOTE, otherwise it is ignored. The Host may request local operation for an Operator to perform maintenance or inspection of the machine. The Host may request a return to operation under its command by delivering the REMOTE command.
REMOTE	This command is successful if the current Control State is OnLine - LOCAL, the Process State is IDLE and the configuration allows remote operation. Return to the REMOTE state following an ALARM or ABORT command without proper Operator inspection and delivery of a Proceed event may return the machine to the same error state which initially caused the machine to leave the REMOTE state.
ABORT	This command is successful if the current Control State is OnLine - REMOTE, the Process State is Running, and the configuration allows remote operation. This command indicates an error status which prevents further dispensing operation until the error is corrected. Dispensing is immediately stopped and the current process program is terminated. Operator intervention and maintenance is generally required in order to resume operation past this point

1.11.6.3 Material Movement

Fluidmove declares two material movement events. The event notifications to the Host are: Dispensing and DispensingDone.

Movement of the board into the ready position for dispensing invokes the Dispensing event. Transfer of the board out of the ready position after dispensing invokes the DispensingDone event.

1.11.6.4 Terminal Message Notification

After a terminal message has been received from the Host, the GEM status bar at the bottom of the Fluidmove Run Window will start blinking. See Figure 1-1. GEM status bar displays the current communication, control, and spooling state. If the user has selected the beeping option (through the SECS/GEM Setup dialog box) a half-second interval beep is also provided to catch the user's attention.

During run-time, the GEM status bar is displayed. The Run Window's SECS/GEM tab is responsible for displaying the incoming terminal message. See Figure 1-7 for all screen features.

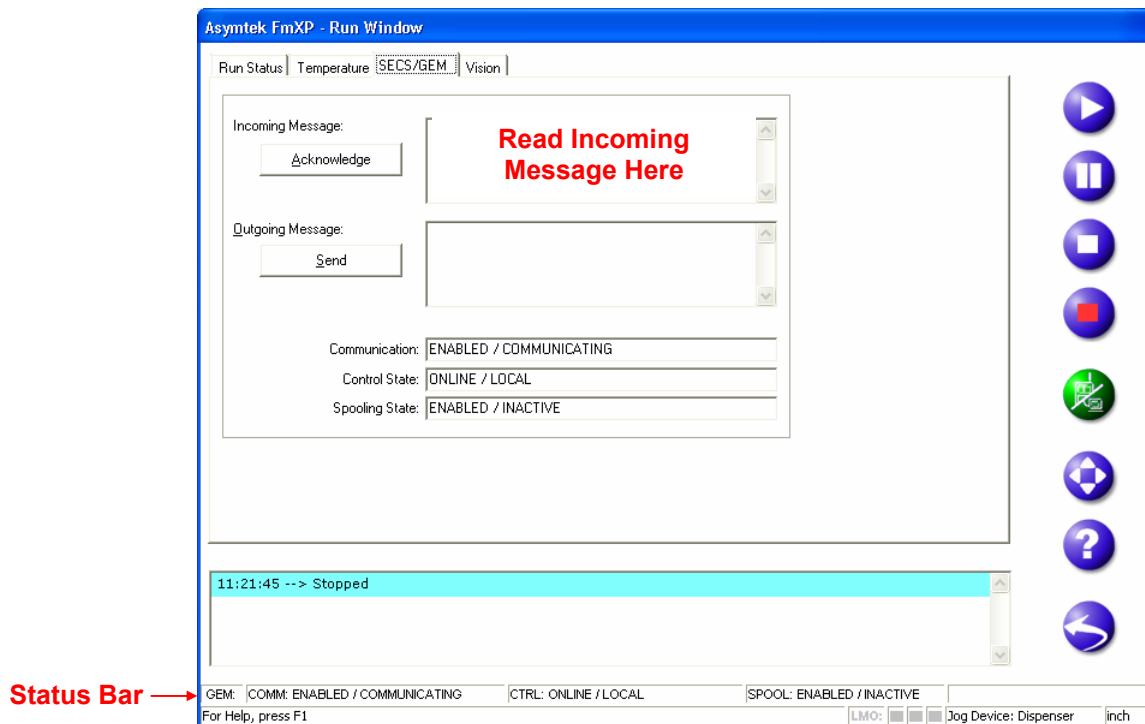
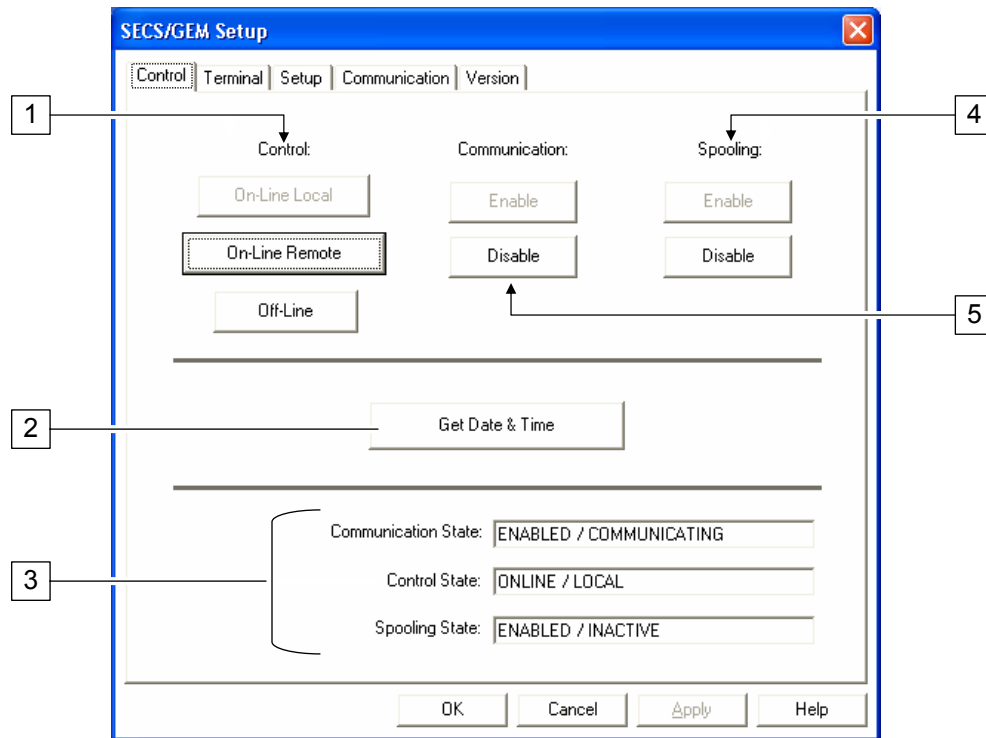

Figure 1-1 Terminal Message Notification (FmXP shown)

1.11.7 SECS/GEM Setup Dialog Box in Fluidmove

The SECS/GEM Setup dialog box can be accessed by pressing the SECS/GEM button in the Fluidmove Main Window. The dialog box contains tabs with buttons and drop-down menus for control and setup of GEM features. These tabs are described in Figure 1-2 through Figure 1-7.



Item	Name	Description
1	Control	<p>On-Line Local: The Operator has control of the system. The system will reject most Host commands. The Host can monitor operations, but cannot control processing. In this state, the system will not accept a REMOTE command from the Host.</p> <p>On-Line Remote: The Host has control of the system. The Operator may issue a Pause, Stop, or Abort command.</p> <p>Off-Line: Puts the system Off-Line.</p>
2	Get Date & Time	Requests current date and time from the Host.
3	Status Box	Displays the current communication state, control state, and spooling state.
4	Spooling	<p>Disable: Neither messages nor commands will be spooled and re-sent if the communications link between the Host and the dispensing system is temporarily disrupted.</p> <p>Enable: Messages and commands will be spooled and re-sent if the communications link between the Host and the dispensing system is temporarily disrupted.</p>
5	Communication	<p>Disable: The SECS/GEM link with the Host is disconnected.</p> <p>Enable: The SECS/GEM link with the Host is established and communication can take place.</p>

Figure 1-2 SECS/GEM Setup Dialog Box – Control Tab (FmXP shown)

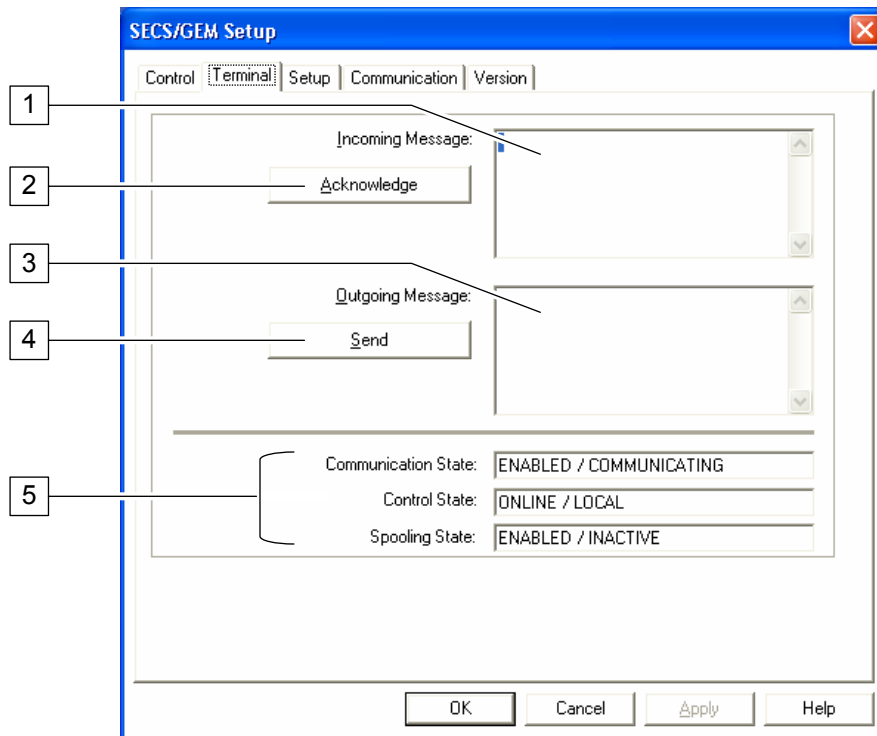

Item	Name	Description
1	Incoming Message	Messages from the Host are displayed in this box.
2	Acknowledge	Press to acknowledge receipt of the incoming message from the Host.
3	Outgoing Message	Enter messages to the Host in this box.
4	Send	Press to send the message in the Outgoing Message box.
5	Status Box	Displays the current communication state, control state, and spooling state.

Figure 1-3 SECS/GEM Setup Dialog Box – Terminal Tab (FmXP shown)

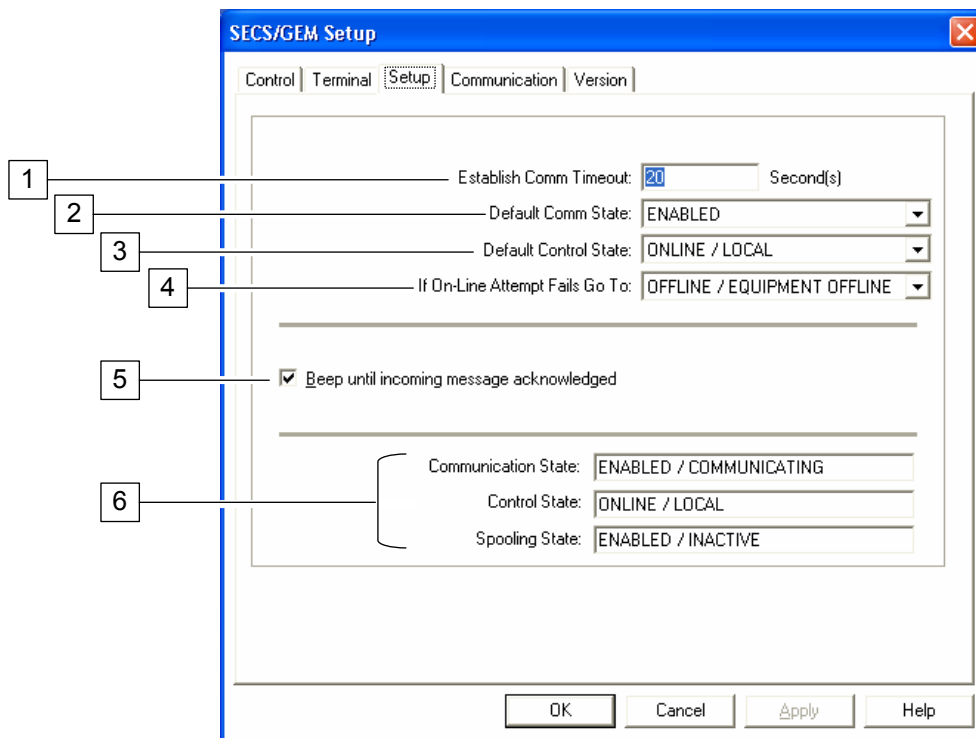

Item	Name	Description
1	Establish Communication Timeout	The user-configurable equipment constant that defines the delay, in seconds, between attempts to send S1F13. This value is used to initialize the CommDelay timer.
2	Default Communication State	Allows the user define the default communication state upon Fluidmove's startup. The valid choices are: <u>ENABLED</u> : Fluidmove will attempt to establish communication link upon start up. <u>DISABLED</u> : Fluidmove will not attempt to establish communication link upon startup. Recommended: ENABLED
3	Default Control State	Allows the user define the default control state upon Fluidmove's startup. The valid choices are: OFFLINE/ATTEMPT ONLINE, OFFLINE/EQUIPMENT OFFLINE, OFFLINE/HOST OFFLINE, ONLINE/LOCAL, ONLINE/REMOTE Refer to 5.4 Control State for descriptions. Recommended: ONLINE/REMOTE
4	If On-line Attempt Fails Go To	Allows the user to select what to do if attempting to go on-line fails for any reason. The valid choices are: OFFLINE/HOST OFFLINE, OFFLINE/EQUIPMENT OFFLINE Refer to 5.4 Control State for descriptions. Recommended: OFFLINE/HOST OFFLINE
5	Beep Until Incoming Message Acknowledged	If selected, Fluidmove will beep twice a second to notify the user of arrival an incoming terminal message from the Host. The GEM status bar blinks at the same rate to catch user's attention regardless of this option being selected or not. The user should then go to the Terminal tab to view and acknowledge the message.
6	Status Box	Displays the current communication state, control state, and spooling state.

Figure 1-4 SECS/GEM Setup Dialog Box – Setup Tab (FmXP shown)

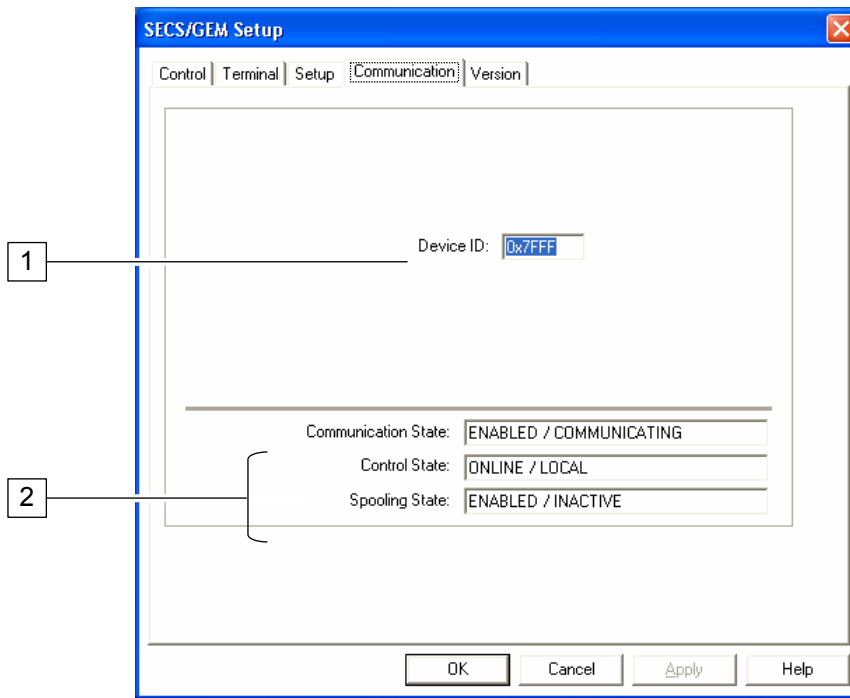

Item	Name	Description
1	Device ID	Displays the unique identifier for the Equipment.
2	Status Box	Displays the current communication state, control state, and spooling state.

Figure 1-5 SECS/GEM Setup Dialog Box – Communication Tab (FmXP shown)

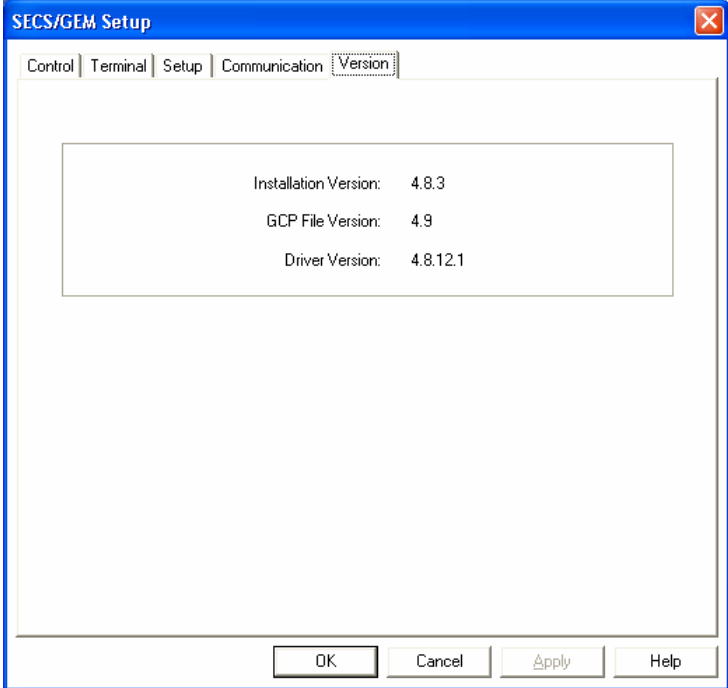
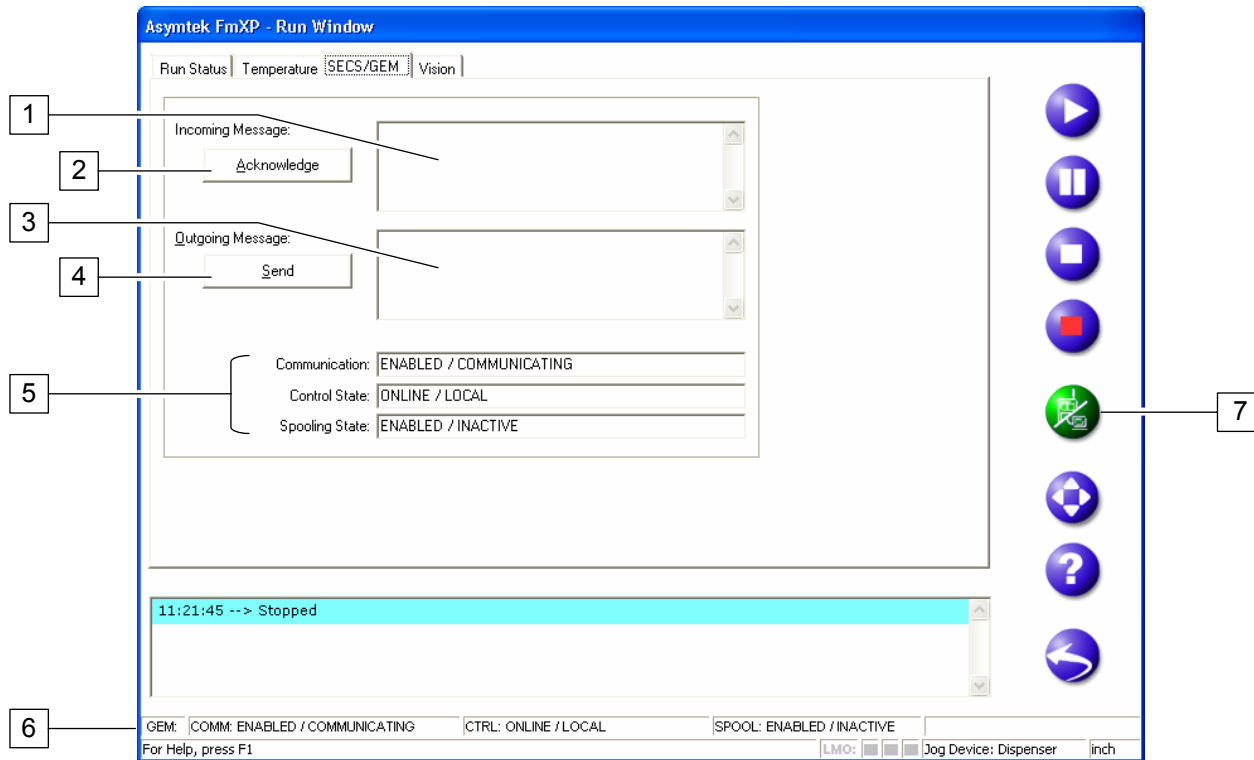

Figure 1-6 SECS/GEM Setup Dialog Box – Version Tab (FmXP shown)

1.11.8 Fluidmove Run Window Interface

The Fluidmove Run Window includes a SECS/GEM tab that shows communication status and allows messages to be sent between the Host and the Operator. This tab is described in Figure 1-7.



Item	Name	Description
1	Incoming Message	Messages from the Host are displayed in this box.
2	Acknowledge	Click to acknowledge receipt of the incoming message from the Host.
3	Outgoing Message	Enter messages to the Host in this box.
4	Send	Click to send the message in the Outgoing Message box to the Host.
5	Status Box	Displays the current communication state, control state, and spooling state.
6	GEM Status Bar	<u>COMM</u> : Displays the GEM communication state of the program. <u>CTRL</u> : Displays the control state of the program. <u>SPOOL</u> : Displays the spooling state of the program.
7	SECS/GEM Communication Indicator	A green button is present when the GEM communication link is established. Otherwise, the button is not displayed.

Figure 1-7 Run Window – SECS/GEM Tab (FmXP shown)

2 Message Summary

This section covers the primary SECS messages sent and received between the Host and the Equipment.

2.1 Host-to-Equipment Messages

Table 2-1 describes primary SECS messages sent by the Host, and the associated reply messages from the Equipment.

The **CState** column indicates the control state the Equipment must be in to accept the message. The current value of the Equipment Control State can be found in variable CONTROLSTATE (VID 4). Possible control state values for this column are listed in [Table 2-2](#).

Unlawful messages sent to the Equipment while Control State is Off-Line (1, 2, or 3) will be replied to with a SnF0 message. Thus, the Host will see only values of 4 or 5 for CONTROLSTATE.

Refer to [Table 7-1](#) for further message detail.

In the **Notes** column, those messages marked with “E” are extensions beyond GEM. Those messages marked with “N” are provided for non-GEM or older GEM compatibility.

Table 2-1 SECS Messages – Host-to-Equipment

Primary	Reply	CState	Description	Notes
S1F1	S1F2	4,5	Are You There	
S1F3	S1F4	4,5	Selected Status	
S1F11	S1F12	4,5	Status Variable Namelist Request	
S1F13	S1F14	All	Connect Request	
S1F15	S1F16	4,5	Request Off-Line	
S1F17	S1F18	1,2,3	Request On-Line	
S1F65	S1F66	All	Connect Request	N
S2F13	S2F14	4,5	Equipment Constant Request	
S2F15	S2F16	4,5	New Equipment Constant Send	
S2F17	S2F18	4,5	Date and Time Request	
S2F21	S2F22	5	Remote Command	N
S2F23	S2F24	4,5	Trace Initialize	
S2F25	S2F26	4,5	Loopback Diagnostic	E
S2F27	S2F28	5	Initiate Processing Request	N
S2F29	S2F30	4,5	Equipment Constant Namelist Request	E
S2F31	S2F32	4,5	Date and Time Send	
S2F33	S2F34	4,5	Define Report	

Table 2-1 SECS Messages – Host-to-Equipment (continued)

Primary	Reply	CState	Description	Notes
S2F35	S2F36	4,5	Link Event Report	
S2F37	S2F38	4,5	Enable/Disable Event Report	
S2F39	S2F40	4,5	Multi-Block Inquire/Grant	
S2F41	S2F42	5	Remote Command with Parameters	
S2F43	S2F44	4,5	Reset Spooling Streams and Functions	
S2F45	S2F46	4,5	Define Variable Limits Attributes	
S2F47	S2F48	4,5	Variable Limit Attribute Request	
S5F3	S5F4	4,5	Enable/Disable Alarm	
S5F5	S5F6	4,5	List Alarms	
S5F7	S5F8	4,5	List Enabled Alarms	E
S6F15	S6F16	4,5	Request Event Report	
S6F17	S6F18	4,5	Request Annotated Event Report	E
S6F19	S6F20	4,5	Request Report	
S6F21	S6F22	4,5	Request Annotated Report	E
S6F23	S6F24	4,5	Request Spooled Data	
S7F1	S7F2	4,5	Process Program Inquire/Grant	
S7F3	S7F4	4,5	Unformatted Process Program Send	
S7F5	S7F6	4,5	Unformatted Process Program Request	
S7F17	S7F18	4,5	Process Program Delete	
S7F19	S7F20	4,5	Process Program Directory	
S10F3	S10F4	4,5	Terminal Display, Single	
S10F5	S10F6	4,5	Terminal Display, Multiple	
S10F9	S10F10	4,5	Broadcast	E

Table 2-2 Control State Values

Value	State
1	Off-Line/Equipment Off-Line
2	Off-Line/Attempt On-Line
3	Off-Line/Host Off-Line
4	On-Line/Local
5	On-Line/Remote

2.2 Equipment-to-Host Messages

Table 2-3 describes primary SECS messages sent by the Equipment, and the associated reply messages from the Host.

Refer to [Table 8-1](#) for further details.

In the **Notes** column, those messages marked with “N” are provided for non-GEM or older GEM compatibility.

Table 2-3 SECS Messages – Equipment-to-Host

Primary	Reply	Description	Notes
-- (any)	SnF0	Primary rejected while Off-Line	
S1F1	S1F2	Are You There	
S1F13	S1F14	Connect Request	
S1F65	S1F66	Connect Request	N
S2F17	S2F18	Date and Time Request	
S5F1	S5F2	Alarm Report	N
S5F71	S5F72	Alarm Report Block Send	
S5F73	S7F74	Alarm Notification Send	
S6F1	S6F2	Trace Data Send	
S6F3	S6F4	Annotated Event Report Send	N
S6F5	S6F6	Multi-Block Data Send Inquire/Grant	
S6F9	S6F10	Event Report Send	N
S6F11	S6F12	Event Report Send	
S6F13	S6F14	Annotated Event Report Send	N
S7F1	S7F2	Process Program Inquire/Grant	
S7F3	S7F4	Unformatted Process Program Send	
S7F5	S7F6	Unformatted Process Program Request	
S9F1	--	Error, Device ID	
S9F3	--	Error, Stream	
S9F5	--	Error, Function	
S9F7	--	Error, Data	
S9F9	--	Error, Transaction Timeout	
S9F11	--	Error, Data Too Long	
S10F1	S10F2	Terminal Request	

3 Operating Characteristics

This section describes the operating characteristics of the Equipment.

3.1 Communications States

The Equipment represents the current state of its SECS link using a Communication Finite State Machine diagram. The purpose is to make clear how this link is initiated and terminated.

The Communications State is displayed in the GEM status bar and the SECS/GEM tab of the Fluidmove Run Window.

Initially, the INITCOMMSTATE variable is set to place the Equipment into the Disabled state at power-up. Once Fluidmove has completed initialization, Fluidmove will change the Communications State to the default communication state selected by the user. The loss of communications during Running or Pausing will not affect the ability of Fluidmove to complete operations in the Process Program. However, automatic reestablishment of the Process State may require manual intervention if Fluidmove has changed state during the loss of communications period.

3.1.1 Communications Finite State Description

Figure 3-1 illustrates the Communications Finite State Machine that the Equipment maintains.

 **NOTE** Refer to Table 3-1 for definition of numbers used in Figure 3-1.

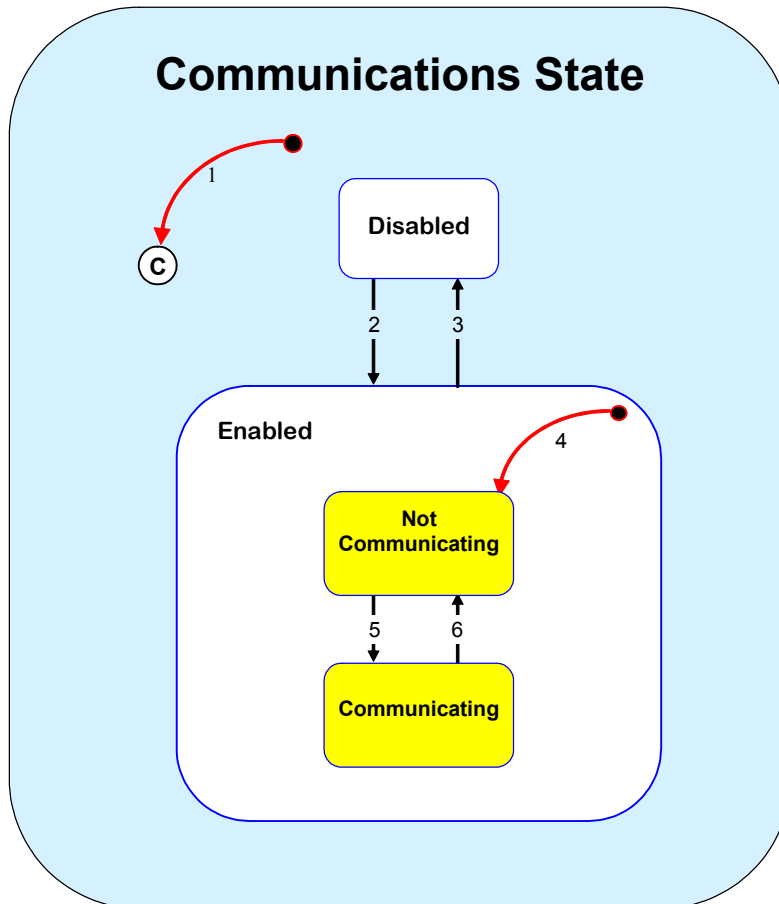

Figure 3-1 Communication Finite State Diagram

3.1.1.1 State Transitions

The following table describes the transitions that can occur. Transitions shown in Figure 3-1 do not cause the Equipment to signal any Collection Event ID (CEID) or to send Event Reports to the Host.

 **NOTE** The numbers in the # column refers to those in Figure 3-1.

Table 3-1 State Transitions

#	From	Trigger	To	Description
1	Unknown	Power-Up	Conditional	Equipment will initialize itself to either the Disabled or Enabled state, depending on the configuration of the EC INITCOMMSTATE (VID 7).
2	Disabled	Operator enables SECS link.	Enabled	Equipment will attempt to establish communications with the Host. The Equipment will periodically send a Connect Request at an interval dictated by the EC ESTABLISHCOMMUNICATIONS-TIMER (VID 44).
3	Enabled	Operator disables the SECS link.	Disabled	Communications are abruptly terminated. Any outstanding messages queued for send are discarded. The Equipment will not respond to a Host-initiated ENQ.
4	Disabled or Power-Up	Request has been made for the Equipment to start communicating.	Not Communicating	Equipment immediately attempts to establish communications with the Host. The Equipment will periodically send a Connect Request message at an interval dictated by the EC ESTABLISHCOMMUNICATIONS-TIMER (VID 44).
5	Not Communicating	Successful completion of Connect Request transaction.	Communicating	The Host / Equipment link is "up". Normal SECS transactions can occur.
6	Communicating	A Communications failure has occurred.	Not Communicating	Equipment immediately attempts to establish communications with the Host. The Equipment will periodically send a Connect Request message at an interval dictated by the EC ESTABLISHCOMMUNICATIONS-TIMER (VID 44).

3.1.1.2 Communications States

The current communication state will be one of the values specified in Table 3-2. There is no variable indicating the communication state. The communication state is presented to the Operator on the main Operator interface screen.

Table 3-2 Communication State Values

Value	Description
DISABLED	The SECS link to the Host is disabled at the Equipment. The Equipment will send no messages to the Host. The Equipment will not respond to a Host-initiated ENQ.
ENABLED	When communications are Enabled, the Equipment's intention is to be in communication with the Host. Whether or not the Equipment is currently communicating with the Host determines which sub-state of the Enabled super-state the Equipment is in.
ENABLED/COMMUNICATING	<p>The SECS link between the Equipment and the Host is operating normally.</p> <p>Periodically, the Equipment will send a "Heartbeat" message S1F1 to ensure that the link is still operating. The heartbeat frequency is controlled by equipment constant "HEARTBEAT". "HEARTBEAT" (VID 26) can range from 0 to 32000, with default value 30.</p> <p>If the Equipment encounters a SECS-I Retry Limit (RTY) error when attempting to send a block to the Host, it discards any messages queued for send and the communication state transits to ENABLED.</p>
ENABLED/NOT COMMUNICATING	<p>The SECS link to the Host is enabled at the Equipment, and the Equipment is attempting to determine if the link is active. The Equipment periodically sends S1F13 (Establish Communications Request). If the connect is not successful for any reason, the Equipment will try again periodically forever. The time between attempts is controlled by the equipment constant "ESTABLISHCOMMUNICATIONSTIMER". This variable (VID 44) can range from 0 to 32000 seconds, with default of 60 seconds.</p> <p>Once the Host has responded with S1F14 (Establish Communications Acknowledge), the Communication State will change to COMMUNICATING.</p> <p>The Host can also attempt to establish communications by sending S1F13. The Equipment will accept the message and respond with S1F14 and the Communication State will change to COMMUNICATING.</p> <p>In ENABLED state, the Equipment will accept messages from the Host, but will ignore any messages except S1F13 and S1F14. The Equipment will respond to the S1F13 while the Communication State is ENABLED or COMMUNICATING, but it will not send S1F13 once communications have been established.</p>

3.1.2 Power Up

At Power Up (or System Start), the equipment constant “INITCOMMSTATE” (VID 7) controls whether the state is initialized to DISABLED or ENABLED. The factory setting is DISABLED.

3.1.3 Related Variables

Table 3-3 lists the variables (SVs, ECs, or DVs) which are relevant to establishing communications. For a more complete description of these variables, refer to [Appendix A](#).

Table 3-3 Related Variables

Variable Name	VID
CONFIGCONNECT	2
INITCOMMSTATE	8
ESTABLISHCOMMUNICATIONSTIMER	6
HEARTBEAT	10
CONFIGSPOOL	63

3.1.4 Compatibility

If the Host intends to use the Control State Off-Line feature, CONFIGCONNECT should always be set to S1F13/14.

3.2 Control States

This section describes the Control characteristics of the Equipment. The Equipment may be in one of the control states in the following table. This value is reflected in status variable CONTROLSTATE (VID 28).

Table 3-4 Control States

Value	State
1	Off-Line/Equipment Off-Line
2	Off-Line/Attempt On-Line
3	Off-Line/Host Off-Line
4	On-Line/Local
5	On-Line/Remote

GWGEM software maintains the GEM Control State finite state machine.

Fluidmove provides the following:

- GUI display of the current State.
- Provide Operator commands for Go Local and Go Remote.
- When ControlState is LOCAL, reject remote commands are appropriately rejected.
- When ControlState is REMOTE, reject local commands are appropriately rejected.

The current Control State is displayed in the GEM status bar in lower portion of all windows. In Remote State configuration, teaching, and tools features are not available to the Operator. This prevents the Operator from interfering with remote operations.

3.2.1 Control Finite State Description

Figure 3-2 and Table 3-5 describe the Equipment Control State. The Equipment behaves differently and will accept different messages depending on its current control state. The purpose of this diagram is to make clear to the Host exactly what is happening at the Equipment. The logic for these states and transitions is the logic specified in the GEM standard.

 **NOTE** Refer to Table 3-5 for definition of numbers used in Figure 3-2.

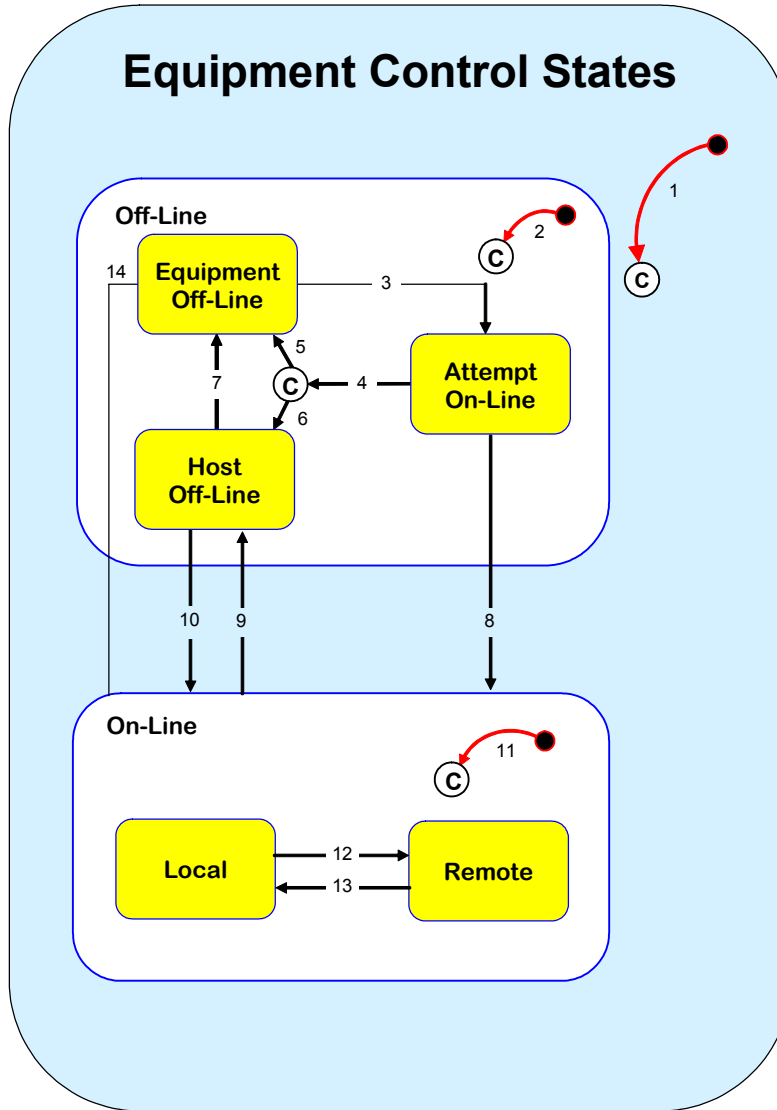

Figure 3-2 Equipment Control State Diagram

3.2.1.1 Control State Transitions

Certain state transitions will cause a collection event to be signaled. If the event is enabled, this event will be sent to the Host along with the appropriate reports if appropriate. Table 3-5 lists the state transitions and notes when events will be sent to the Host.

 **NOTE** The numbers in the # column refer to those in Figure 3-2.

Table 3-5 Control State Transitions

#	From	Trigger	To	Description
1	Unknown	Power-Up	Conditional	This transition is made to either the Off-Line or On-Line state, depending on the EC INITCONTROLSTATE (VID 9).
2	Unknown	Power-Up	Conditional	This conditional transition is governed by the value of the OFFLINESUBSTATE EC (VID 42).
3	Equipment Off-Line	Operator requests to go On-Line.	Attempt On-Line	The Equipment will immediately send an S1F1 to request to go On-Line.
4	Attempt On-Line	Unsuccessful On-Line request	Conditional	This transition occurred because the Host did not reply to an S1F1 with an S1F2 or because the S1F1 was not successfully sent.
5	Conditional	ONLINEFAILED Equipment Constant configured to Equipment Off-Line.	Equipment Off-Line	Equipment will allow the Operator to attempt to go On-Line again.
6	Conditional	ONLINEFAILED Equipment Constant configured to Host Off-Line.	Host Off-Line	The Equipment will accept a Host initiated request to go On-Line by replying to the S1F17 with ONLACK = 0x00.
7	Host Off-Line	Operator requests to go Off-Line.	Equipment Off-Line	A Host request to go On-Line will not be accepted.
8	Attempt On-Line	Successful On-Line request.	On-Line	The Equipment is now On-Line.

Table 3-5 Control State Transitions (continued)

#	From	Trigger	To	Description
9	On-Line	Host puts the Equipment Off-Line by sending S1F15 and receiving the S1F16 with OFLACK = 0x00.	Host Off-Line	EVENT: GemEquipmentOFFLINE (CEID 22). The Equipment will accept a Host initiated request to go On-Line by replying to the S1F17 with ONLACK = 0x00.
10	Host Off-Line	Successful completion of S1F17 / S1F18 transaction, with ONLACK = 0x00.	On-Line	The Equipment is now On-Line.
11	Unknown	Entry into On-Line super-state.	Conditional (Local or Remote)	EVENT: GemControlStateLOCAL (CEID 8) or GemControlStateREMOTE (CEID 9). The Equipment will transition to whichever state is specified in the EC ONLINE- SUBSTATE (VID 44).
12	Local	Operator or Host requests to go Remote.	Remote	EVENT: GemControlStateREMOTE (CEID 9). All documented messages will be accepted in this state, including remote commands.
13	Remote	Operator or Host requests to go Local.	Local	EVENT: GemControlStateLOCAL (CEID 8). Remote commands will be rejected. Except for the REMOTE command.
14	On-Line	Operator requests to go Off-Line.	Equipment Off-Line.	EVENT: GemEquipmentOFFLINE (CEID 3). A Host request to go On-Line will not be accepted.

3.2.1.2 Control States

The variable CONTROLSTATE (VID 28) represents the current control state, and will be one of the values listed in Table 3-6.

Table 3-6 Control State Values

Value	Description
Off-Line/EQUIPMENT OFF-LINE	The Operator has put the Equipment off-line. In this state, only the Operator can put the Equipment on-line. Any Host-initiated primary message (except S1F13 and S1F17) will be replied to with an SnF0 ABORT message by the Equipment. The Equipment will not send any primary messages except for S1F13 when necessary to establish communications, and the S9F1 and S9F9 messages for SECS errors.
Off-Line/HOST OFF-LINE	<p>While in this state, the Equipment will accept either the S1F17 (Go Online), or the S1F13 (Connect Request) message. When in this state, the Operator has allowed the Host to put the Equipment on-line, but the Host has not yet done so, or the Host has just put the Equipment off-line by sending S1F15. The Host may request for the Equipment to come on-line by sending the S1F17 (Go Online) message. The Operator cannot put the Equipment on-line from this state.</p> <p>The S1F13/S1F14 messages are used to maintain the Communications Finite State Machine. All messages (except S1F13 and S1F17) received will be replied to with the SnF0 ABORT message. The Equipment will not send any primary messages except for S1F13 when necessary to establish communications, and the S9F1 and S9F9 messages for SECS errors.</p>
Off-Line/ATTEMPT ON-LINE	The Operator has requested that the Equipment go On-Line, causing the transition to this state. The Equipment sends a single S1F1, indicating its desire to go on-line. When either a transmission failure (T3 or RTY errors) occurs or a successful reply to the S1F1 has been received, a transmission is made out of this state.
On-Line/LOCAL	<p>The local Operator has control of the Equipment. The Host can send S2F41 (Remote Command), but the Equipment will reject it with 0x40 return code. The REMOTE command sent by the Host will not be rejected by the Equipment. See 3.7 Remote Commands or 4.2.41 S2F42 - Remote Command Acknowledge for details.</p> <p>In LOCAL mode, the Equipment continues to send event and alarm reports to the Host. The Host can monitor operations, but cannot control processing. However, the Host can still exert “controls” other than S2F41 which do not directly affect processing. For example, the Host can enable/disable alarms and set the clock.</p>
On-Line/REMOTE	<p>The remote Host Computer has control of the Equipment using S2F41 (Remote Command). For details refer to 3.7 Remote Commands.</p> <p>The Operator may issue the PAUSE, STOP, and ABORT commands while in Remote state. These commands will generate an OperatorCommand event (CEID 4) as well as other messages attached to these activities. Refer to Appendix B for further detail.</p>

3.2.2 Power Up

At power-up, the equipment constant “INITCONTROLSTATE” (VID 9) controls whether ControlState is initialized to ONLINE or OFFLINE. Within the Off-Line super-state, the equipment constant “OFFLINESUBSTATE” (VID 42) controls whether the Control State defaults to:

1. Equipment Off-Line
2. Host Off-Line
3. Attempt On-Line

If INITCONTROLSTATE (VID 9) initializes to On-Line, the variable ONLINESUBSTATE (VID 44) determines whether the default state is:

1. Local
2. Remote

When the Operator changes the default control state through Fluidmove’s SECS/GEM Setup dialog box, INITCONTROLSTATE gets updated. ONLINE/REMOTE is recommended for this value.

3.2.3 Related Variables

Table 3-7 lists the variables (SVs, ECs, or DVs) which are relevant to the Control State. For a more complete description of these variables, refer to [Appendix A](#).

Table 3-7 Control State Variables

Variable Name	VID
INITCONTROLSTATE	9
OFFLINESUBSTATE	42
ONLINEFAILED	43
ONLINESUBSTATE	44
CONTROLSTATE	28
PREVIOUSCONTROLSTATE	35

3.2.4 Related Events

Table 3-8 lists the collection events (CEIDs) which are relevant to the Control State. For a more complete description of these events, refer to [Appendix B](#) or the description in this chapter.

Table 3-8 Control State CEIDS

Collection Event	CEID
GemControlStateLOCAL	8
GemControlStateREMOTE	9
GemEquipmentOFFLINE	22

3.3 Process States

See [Figure 3-4](#) for a description of the Fluidmove processing state model.

The Process State changes in response to either Operator or Host command inputs. Change of control state from local to remote or vice versa is only allowed in the Idle Process State. This prevents loss of command synchronization.

The Host may command Start, Stop, Pause, Resume, Local, Remote, and Abort. The Operator may command Start, Stop, Pause, Resume, Local, Remote, and Abort.

3.3.1 E10 State

Figure 3-3 illustrates the state of the Equipment in relationship to overall factory production. The E10 state diagram is implemented in the Equipment according to the details specified in the SEMI E10 document. The following summarizes the Equipment's implementation of the E10 standard:

The Equipment can transition from any state to any other state except for "Productive". The "Productive" state can only be entered from the "Standby" state. Upon startup, the Equipment is in "Non-Scheduled Time".

E10 states are not available to the host computer via SECS/GEM.

 **NOTE** Refer to Table 3-9 for definition of numbers used in Figure 3-3.

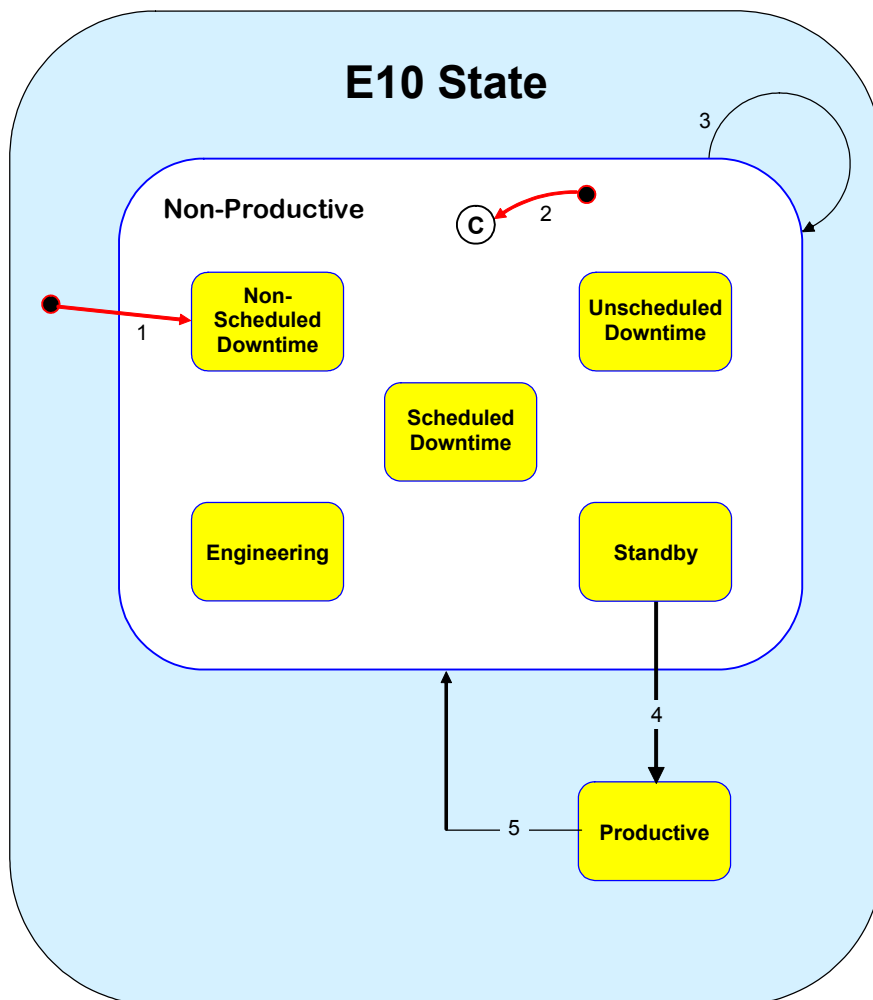

Figure 3-3 E10 State Diagram

3.3.1.1 E10 State Transitions

Certain state transitions will cause a collection event to be signaled. If the event is enabled, this event will be sent to the Host along with the appropriate reports if appropriate. Table 3-9 lists the state transitions and notes when events will be sent to the Host.

 **NOTE** The numbers in the # column refer to those in Figure 3-3.

Table 3-9 E10 State Transitions

#	From	Trigger	To	Description
1	Unknown	Power-Up	Non-Scheduled Time	Upon Power-Up, the Equipment defaults to this state.
2	Unknown	Operator Request	Conditional	The Operator changes states from the previous state to the new state. The conditional depends on the Operator's intentions.
3	Non-Productive	Operator Request	Non-Productive	–
4	Standby	Processing of material begins.	Productive	Equipment is processing material.
5	Productive	Operator Request	Non-Productive	The Operator changes states from Productive to a new Non-Productive state. Transition will be made according to conditional transition #2.

3.3.1.2 E10 STATE Values

The values for E10 states are listed in Table 3-10.

Table 3-10 E10 State Values

Value	Description
Non-Productive/Non-Scheduled Time	The Equipment is not scheduled to be used in production. An Operator can put the Equipment into this state at any time.
Non-Productive/Unscheduled Downtime	The Equipment has been scheduled to be used in production, but is unable to be used because of unforeseen events. Possible reasons for transitions into this state include: 1) maintenance delay 2) repair 3) replacement of a disposable 4) bad input (bad boards, etc.) 5) facility related downtime
Non-Productive/Scheduled Downtime	The Equipment has been scheduled to be out of production so that maintenance can be performed.
Non-Productive/Engineering	The Equipment may be actively running boards, but these are not intended to be used in normal production. This state signifies that Engineering data is being gathered from the Equipment separate from an actual productive run.
Non-Productive/Standby	The Equipment is ready for production, but is awaiting resources. These resources may be in the form of physical material (boards) or in the form of information (process program, and START command).
Productive	The Equipment is actively processing boards for use in production.

3.3.2 Equipment Process States

Figure 3-4 illustrates in greater detail the processing at the Equipment. This diagram depicts the working states of the Equipment.

 **NOTE** Refer to Table 3-11 for definition of numbers used in Figure 3-4.

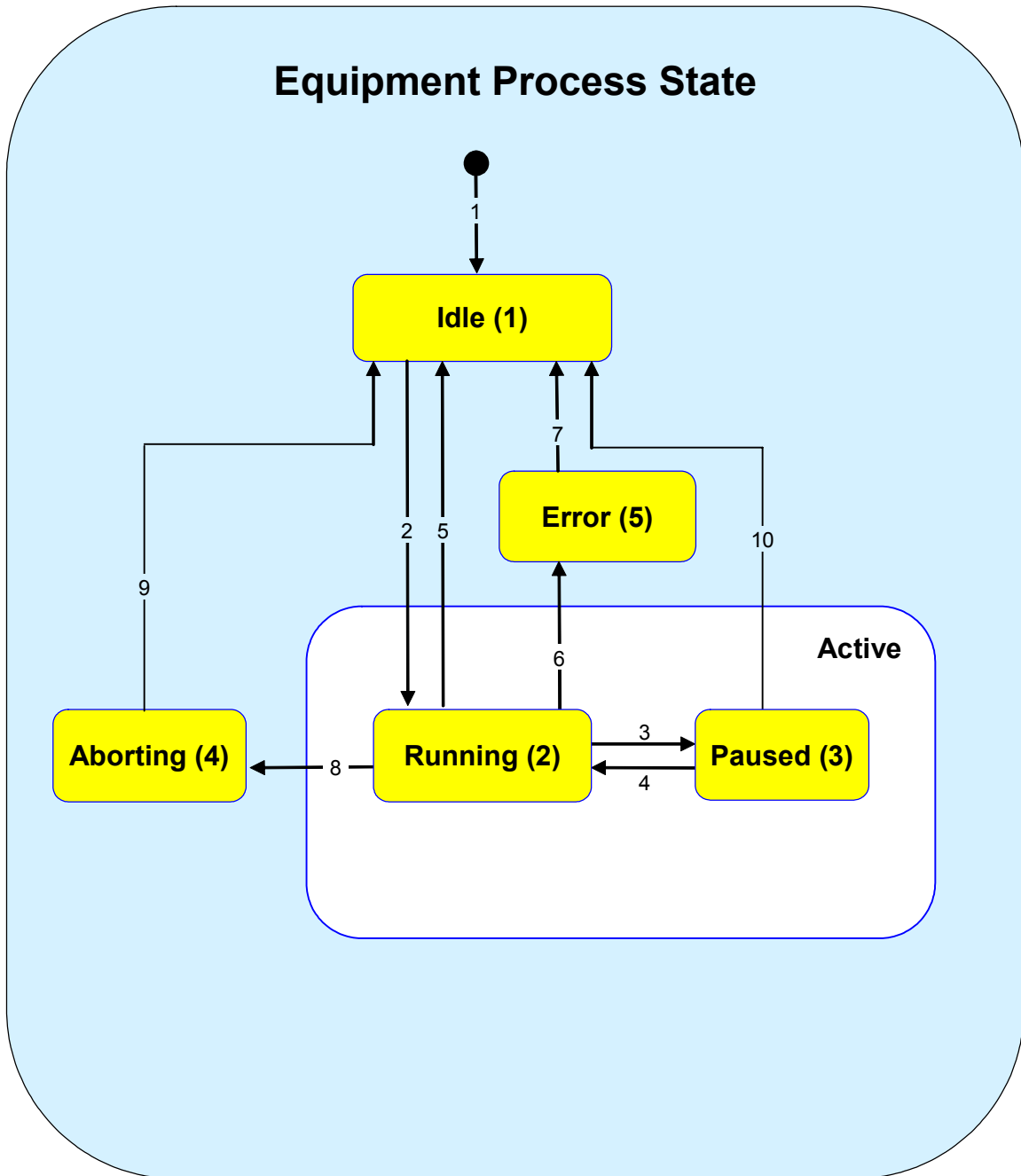

Figure 3-4 Equipment Process States

3.3.2.1 Equipment Process State Transitions

 **NOTE** The numbers in the # column refer to those in Figure 3-4.

Table 3-11 Process State Transitions

#	From	Trigger	To	Description
1	Unknown	Power-Up	Idle	At power-up, the Equipment defaults to the IDLE state.
2	Idle	Run Command	Running	Either the Host or Operator issues a run command. This command can be issued by a remote command from the Host or by local Operator.
3	Running	Pause Command	Paused	Either the Host or Operator issues a pause command. This command can be issued by a remote command from the Host or by local Operator.
4	Paused	Unpause Command	Running	Either the Host or Operator issues an Unpause command. This command can be issued by a remote command from the Host or by local Operator.
5	Running	Stop Command	Idle	Either the Host or Operator issues a Stop command. This command can be issued by a remote command from the Host or by the local Operator. This command will stop processing after the current board has completed.
6	Running	Error Occurrence	Error	An error has occurred on the Equipment.
7	Error	Operator Error Acknowledge	Idle	Once the Operator has acknowledged the error, the Equipment will transition to the Idle state.
8	Running	Abort Command	Aborting	Either the Host or Operator issues an Abort command. This command can be issued by a remote command from the Host or by the local Operator.
9	Aborting	Machine stopped	Idle	Once the machine has halted, the Equipment will transition to the Idle state.
10	Paused	Stop Command	Idle	Either the Host or Operator issues a Stop command. This command can be issued by a remote command from the Host or by the local Operator.

3.3.2.2 Equipment Process State Values

The values for Equipment process states are listed in Table 3-12.

Table 3-12 Equipment Process State Values

Value	Description
Idle	The Equipment is initialized to this state. This state indicates that the Equipment is not dispensing on a board nor is it waiting for a board to arrive at the dispense station.
Active	The Active state includes the following: Running - While in this state, the Equipment is either currently waiting for a board to arrive at the dispense station, processing a board, or unloading a processed board out of the dispense station. Paused - This state indicates that the Equipment is paused during the processing of a board. Processing continues on the current board when the UNPAUSE command is issued. The transition to the Idle state can occur if the stop command is issued.
Aborting	When in the Running state, upon receiving an ABORT command, the Equipment will command the machine to stop all processing immediately. This state indicates that this is currently occurring. Once all processing has been halted, the transition to the Idle state will occur.
Error	An error has occurred while in the Running state. A description of the error will be displayed to the user. Upon acknowledgment of the error, the Equipment will transition to the Idle state.

3.3.3 Related Variables

Table 3-13 lists the variables (SVs, ECs, or DVs) which are relevant to the Equipment processing states. For a more complete description of these variables, refer to [Appendix A](#).

Table 3-13 Equipment Processing Variables

Variable Name	VID
PREVIOUSPROCESSTATE	36
PROCESSTATE	37

3.3.4 Related Collection Events

Many of the Equipment's collection events relate to process state changes. For a complete listing of these, refer to [Appendix B](#).

3.4 Data Collection

Note the three types of variables: Status Variable (SV), Data Variable (DV), and Equipment Constants (EC). The Host sets only ECs. DVs are time stamped by being associated with Collection Events IDs (CEID), and will be reported by Fluidmove in Event Reports.

3.4.1 Variables

The Equipment has a fixed set of Variables which can be read by the Host. Each variable is identified by a unique Variable ID (VID). [Appendix A](#) lists all variables for both Fluidmove and standard GEM operations.

There are three types of variables: Status Variables, Data Variables, and Equipment Constants. The Host can read variables of any type, but can set values only for equipment constants. The Host can read values for Status variables and equipment constants whenever the Equipment is on-line, but values for Data Variables are typically meaningful only immediately after certain Collection Events (CEIDs), and so are typically reported only in Event Reports (S6F11).

3.4.2 Are You There

The Host can send S1F1 at any time to determine if the SECS link is operational. The Equipment responds with S1F2, if the Equipment is in the ONLINE & COMMUNICATING states. This indicates Model Number (MDLN) and Software Revision Number (SOFTREV).

3.4.3 Host Requests Status

The Host can send S1F3 when the Equipment is on-line to read equipment constants.

The Host can send S2F13 when the Equipment is on-line to read equipment constants.

For this Equipment, S1F3 and S2F13 with a list of VIDs are essentially the same. That is, either message can return Variables of any type. However, S1F3 with a zero-length list will return only VIDs of type SV, and S2F13 with a zero-length list will return only VIDs of type EC.

3.4.4 Setting Equipment Constants

The Operator can change the value for equipment constants. Once the Operator has changed an EC value, the Equipment will note the EqConstChange event. The VID for the changed EC will be reported to the Host in the variable ECIDCHANGE.

3.4.5 Event Reports

The Equipment has a fixed set of Events which can occur. Each Event is identified by a unique Collection Event ID (CEID). The CEIDs are listed in [Appendix B](#).

When an event occurs, the Equipment sends the appropriate S6F11 Event Report message to the Host (if that particular event has been enabled). Event Reports are defined by the Host (S2F33) and linked to a specific CEID (S2F35).

The Equipment allows the Host to enable and disable Event Reports using S2F37. If the Host enables a CEID, for which no Event Report is defined, the Equipment will send a “null” (no data) report when the event occurs.

The Host can “force” Event Reports on the Equipment using the following Event Report Request messages:

- S6F15 Host requests an Event Report associated with a CEID.
- S6F17 Host requests an Annotated Event Report associated with a CEID.
- S6F19 Host requests an Event Report associated with a Report ID.
- S6F21 Host requests an Annotated Event Report associated with a Report ID.

3.4.6 Time Driven Trace

The Equipment supports Time Driven Trace initiated from the Host. The Host initializes a trace using S2F23. The Equipment will send the data requested after the specified time interval has expired. The data will be sent using the S6F1 (Trace Data Send) message.

The Equipment can handle several concurrent traces. The number of concurrent traces is determined by the size of the trace data requested. The Equipment can support at least four concurrent traces to a maximum size (i.e. all variables requested).

The Equipment allows Host definition of trace data to exceed the one-block limit when reported. That is, the SEMI E5 standard states that the S6F1 (Trace Data Send) message is limited to a single SECS block; but the Equipment will allow this point to be overlooked at the Host’s request. If the Host does define trace data to be larger than one SECS block, then the Equipment will send the multiple blocks, not preceded by the S6F5/S6F6 Inquire/Grant scenario.

3.4.7 Limits Monitoring

The Host can define limits for various Variables on the Equipment. When the appropriate limits transitions occur, the Equipment will report this occurrence by sending an event to the Host (if the event is enabled). The Host may define limits for a particular Variable through the S2F45 (Define Variable Limit Attributes). Through this message, the Host may define up to seven limits for each eligible Variable. For each limit (LIMITID), the Host defines an UPPERDB and a LOWERDB. The Equipment generates events when a transition across these boundaries occurs. The Host may set the rate at which the Equipment polls the Variables to determine if a limit has been crossed by setting the GEMLIMITSDELAY variable (VID 60).

3.4.7.1 Event Signaling

For any event that exists on the Equipment, the event message will be sent to the Host only if the reporting for that particular event has been enabled. In this “EVENT SIGNALING” section, assume that the Host has enabled the proper reporting so that these events will be sent to the Host.

After the Host sets UPPERDB and LOWERDB values for a particular limit, the Equipment will send an event message when a transition occurs across these boundaries. The procedure for reporting is illustrated in Figure 3-5 and Figure 3-6.

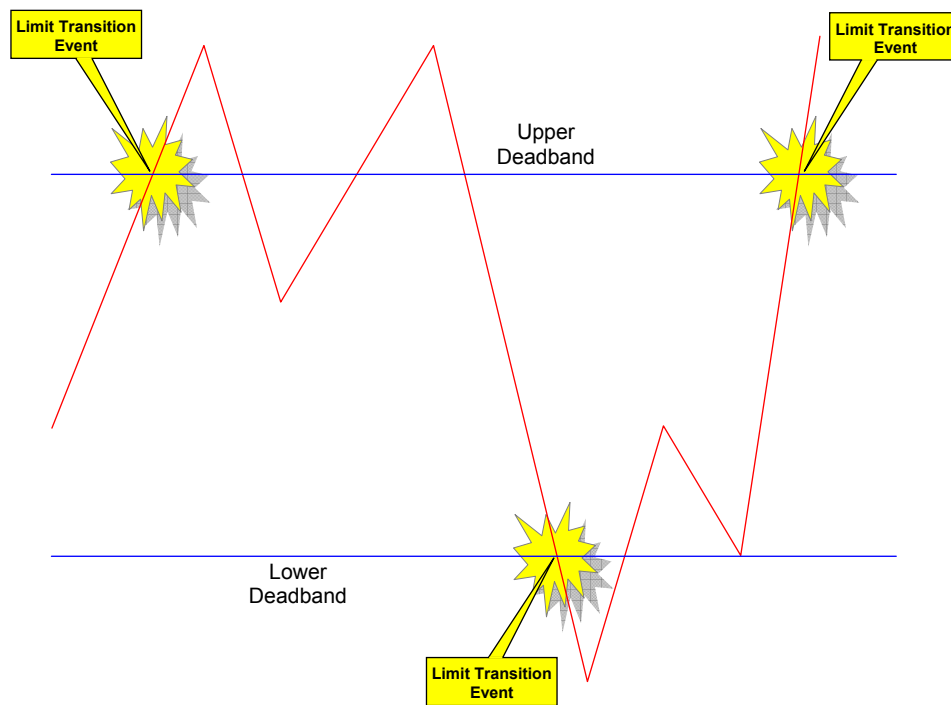

Figure 3-5 Limits Events Signaling

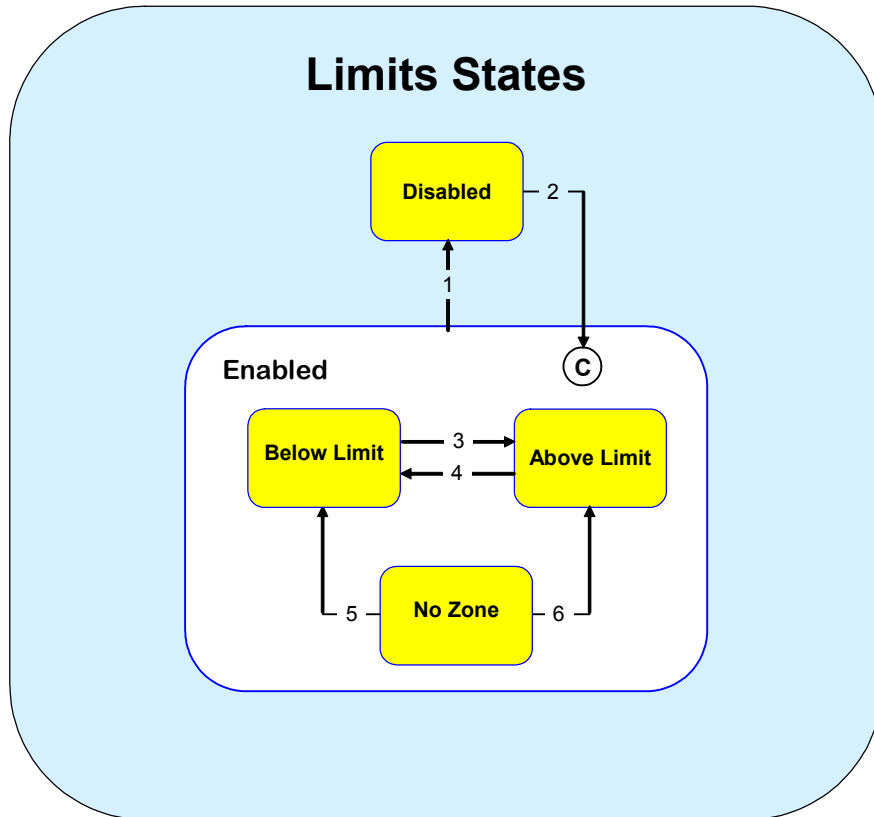

Figure 3-6 Limits State Diagram

3.4.8 Limits State Transitions

Table 3-14 Limits State Transitions

#	From	Trigger	To	Description
1	Enabled	Host undefines limits attributes.	Disabled	Host sends S2F45 to undefine limits.
2	Disabled	Host defines limits.	Conditional	Host sends S2F45 to define limits.
3	Below Limit	Variable changes to greater than or equal to UPPERDB.	Above Limit	Limit transition event is signaled to Host if enabled.
4	Above Limit	Variable changes to less than or equal to LOWERDB.	Below Limit	Limit transition event is signaled to Host if enabled.
5	No Zone	Variable changes to less than or equal to LOWERDB from No Zone.	Below Limit	Limit transition event is signaled to Host if enabled.
6	No Zone	Variable changes to greater than or equal to UPPERDB from No Zone.	Above Limit	Limit transition event is signaled to Host if enabled.

3.4.8.1 Limits States

A variable's defined limits may be in any of the states specified in Table 3-15:

Table 3-15 Limits States

State	Limits
Enabled	Within this super-state, a limit has been defined, and monitoring of the variable is taking place.
Disabled	Limits are not defined.
Below Limit	The value of the variable is less than or equal to LOWERDB.
Above Limit	The value of the variable is greater than or equal to UPPERDB.
No Zone	This limit has just been defined, and the value of the variable is less than UPPERDB and greater than LOWERDB. No limits transitions have occurred.

3.4.9 Disk Files

The Equipment maintains a disk file which contains the current equipment constant settings. The file is updated each time the Operator or Host changes an equipment constant. The most recent settings for some of the equipment constants are read from the file when the Equipment is powered-on.

All Event Report definitions, links, and enable status as well as Limits attributes are also maintained on separate disk files.

3.4.10 Related Variables

The following table lists the variables (SVs, ECs, or DVs) which are relevant to data collection setup and maintenance. This section does not list the variables which contain Equipment-specific information. For a more complete description of specific variables, refer to [Appendix A](#).

Table 3-16 Data Collection / Setup Variables

Variable Name	VID
ECIDCHANGE	67

3.4.11 Related Events

The following table lists the collection events (CEIDs) which are relevant to data collection. In addition to these, each variable which is eligible for limits monitoring must have a specific collection event associated with it. For a more complete description of these events, refer to [Appendix B](#) or the description in this section.

Table 3-17 Data Collection CEIDS

Collection Event	CEID
EqConstChange	20

3.5 Alarm Management

The Equipment has a fixed set of alarm conditions which can occur. Each alarm is identified by a unique Alarm ID (ALID), and has an associated severity code (ALCD) and alarm text (ALTX). Examples of possible alarms are shown in [Appendix C](#).

3.5.1 Alarm States

Each alarm (ALID) can be in either of two states: CLEAR (off) or SET (on). Several alarms can be SET simultaneously. At power-up, all alarms are cleared.

3.5.2 Reporting

The Equipment reports alarms to the Host when they occur, without Host action, using the alarm report message S5F1 or configurable option, depending on CONFIGALARMS. The transition of an ALID from OFF to ON is referred to as “going on” or “leading edge”, and the transition from ON to OFF as “going off” or “trailing edge”. The Equipment reports both leading and trailing edge transitions.

The Equipment has two CEIDs for each ALID, one for the “going on” transition and one for the “going off” transition. In addition to the Alarm Report, the Equipment sends an Event Report if the CEID associated with the alarm change is enabled. If the CEID is enabled and no report is defined, a “null” Event Report is sent. The Event Report for an alarm transition is sent if it is enabled, even if the reporting for the alarm is disabled.

3.5.3 Enable/Disable

The Host can use S5F3 (Enable/Disable Alarms) to control which alarms the Equipment should report. Using S5F3, the Host can specify for each ALID whether the Equipment should report that alarm when it occurs. When an alarm transition occurs, if that ALID is enabled the Equipment will send an alarm report message to the Host. If the ALID is disabled, the Equipment will not send the alarm message. The Host can use S2F37 to enable or disable the CEIDs associated with these alarm transitions.

The Equipment saves Alarm Enable/Disable settings on a disk file. When the Equipment powers up, it will restore Alarm Enable/Disable settings to the same condition they had at power off.

3.5.4 Host Requests Alarm Status

The Host can use S5F5 to request the Equipment to report all alarms which exist and the ON/OFF state for each.

The Host can use S5F7 which is similar, but which causes the Equipment to report only those alarms (ALIDs) which are Enabled, regardless of whether the alarm is ON or OFF.

3.5.5 Compatibility

The Equipment supports the following Alarm Report message formats for older Host implementations (refer to [1.9.3 GEM Configuration](#).)

- S5F71/S5F72
- S5F73/S5F74

3.5.6 Related Variables

The following table lists the variables (SVs, ECs, or DVs) which are relevant to alarm management. For a more complete description of these variables, refer to [Appendix A](#).

Table 3-18 Alarm Management Variables

Variable Name	VID
CONFIGALARMS	1
WBITS5	19
ALARMID	22
ALARMSEENABLED	23
ALARMSSET	24
ALARMSTATE	25
ALARMSERIAL	26

3.5.7 Related Collection Events

Each alarm defined in the Equipment has two unique collection events associated with it: a “Going-On” event, and a “Going-Off” event. The CEIDs are listed in [Appendix B](#).

3.6 Process Program Management

Processing on the Equipment is controlled by Process Programs. The Equipment requires selection of a Process Program for each process. The Equipment supports the use of unformatted process programs.

Fluidmove uses proprietary ASCII and binary image files to define process programs (recipes).

3.6.1 Equipment Management of Process Programs

The Equipment provides a Process Program Library, implemented as a set of binary files maintained on a hard disk. Each Process Program is identified by a unique Process Program ID (PPID). Upper and lower case alphabetic characters are not considered distinct, and the Equipment will not distinguish between them.

For Fluidmove, the PPID corresponds to the name of a recipe file which is the culmination of the main program and various support files.

The Operator may modify any one of the Process Programs stored on the Equipment. The Host will be notified via the GemPPChangeEvent Collection Event if the Operator creates, changes, or deletes a Process Program. The Operator can also select a PPID to be uploaded to the Host (S7F3), or download from the Host (S7F5).

3.6.2 Host Management of Process Programs

Process Programs are saved to disk on the Equipment. Process Programs are typically created and updated at the Equipment. However, the Equipment provides complete facilities for the Host to manage the storage and use of Process Programs. This allows the Equipment to operate cooperatively Host-implemented systems. The Host has the following capabilities:

- The Host can upload a Process Program from the Equipment Library by using S7F5 (Process Program Request). The Operator can also initiate a Process Program Upload through the Equipment's user interface.
- The Host can download a Process Program to the Equipment library by using S7F3 (Process Program Send). The Host may send S7F1 (Multi-block Inquire) to the Equipment before sending a multi-block Process Program. The Operator can also initiate a Process Program Download through the Equipment's user interface.
- The Host can delete one or more Process Programs from the Equipment library by using S7F17 (Process Program Delete).
- The Host can determine which Process Programs are currently stored in the Equipment library by using S7F19 (Process Program Directory).

3.6.3 Related Variables

The following table lists the variables (SVs, ECs, or DVs) which are relevant to process program management. For a more complete description of these variables, refer to [Appendix A](#).

Table 3-19 Process Program Management Variables

Variable Name	VID
PPCHANGENAME	40
PPEXECNAME	32
PPCHANGESTATUS	41

3.6.4 Related Events

The following table lists the collection events (CEIDs) which are relevant to process program management. For a more complete description of these events, refer to [Appendix B](#).

Table 3-20 Process Program Management CEIDs

Collection Event	CEID
GemPPChangeEvent	3
GemBadDownloadEvent	7

3.7 Remote Commands

Processing at the Equipment can be guided by either a local Operator or by a Host computer. This section describes the remote commands available to the Host.

Much of the behavior of the Equipment and its acceptance of remote commands is directed by requirements of the Control State. For a complete description of the Control State, refer to [3.2 Control States](#).

The Equipment will accept remote commands only when the Control State is Remote.

The Host has the ability to configure whether the Equipment will transition to Remote or Local as a default upon entering the On-Line state from Off-Line. This can also be done through the SECS/GEM Setup dialog box in Fluidmove.

Once in the Remote state, the Host has the authority to issue any of these remote commands and they will not be rejected because of an invalid control state. Commands may be rejected for other reasons (trying to start a process with no material loaded, etc.).

While in Remote state, the Operator still has the ability to issue commands and change the control state. If the Operator issues a command while in Remote state, the Equipment will send the Operator Command collection event if enabled. When the Operator “grabs” control away from the Host by changing the Control State to Local, the Equipment will send either the GemControlStateLOCAL or GemEquipmentOFFLINE event to the Host. The Host also has the ability to put the Equipment into a Local state by sending the LOCAL remote command while in Remote state. Furthermore, if the Operator presses any of the buttons on the Run Window (GO, PAUSE, STOP, ABORT), the Host will get the corresponding events (StartCmd, PauseCmd, StopCmd, AbortCmd - refer to [Appendix B](#)).

3.7.1 S2F41 Commands

The general format for remote commands using the S2F41 message is:

```
S2F41 [W] * H->E
  <L [2]
    <A RCMD> * Remote command string
    <L
      <L [2]
        <A CPNAME> * Command Parameter Name
        <CPVAL> * Command Parameter Value
      >
    ...
  >
> .
```

The following commands may be sent by the Host to the Equipment:

START

This command starts processing on the Equipment assuming all proper initialization has taken place and material is present.

```
S2F41 [W]
  <L [2]
    <A 'START'>
    <L>
  > .
```

STOP

This command will stop the processing of material at the Equipment. Boards currently in process will be completed, but no new boards will be loaded.

```
S2F41 [W]
  <L [2]
    <A 'STOP'>
    <L>
  > .
```

PAUSE

The PAUSE command will cause the Equipment to complete the current instruction in process, but not to start the next instruction until the RESUME command has been given.

```
S2F41 [W]
  <L [2]
    <A 'PAUSE'>
    <L>
  > .
```

RESUME

After a PAUSE command has been given, the RESUME command will continue to process the existing board according to the recipe.

```
S2F41 [W]
  <L [2]
    <A 'RESUME'>
    <L>
  > .
```

LOCAL

While the Equipment is in Remote state, the Host can put the Equipment into Local state by sending the LOCAL command.

```
S2F41 [W]
  <L [2]
    <A 'LOCAL'>
    <L>
  > .
```

ABORT

The Host can abort processing at the next safe stopping point by sending the ABORT command with the AbortLevel parameter as follows:

```
S2F41 [W]
  <L [2]
    <A 'ABORT'>
    <L
      <L
        <A 'AbortLevel'> *CPNAME
        <U1 1> *CPVAL
      >
    >
  > .
```

3.7.2 Related Variables

The following table lists the variables (SVs, ECs, or DVs) which are relevant to remote control. For a more complete description of these variables, refer to [Appendix A](#).

Table 3-21 Remote Control Variable

Variable Name	VID
ABORTLEVEL	21
PREVIOUSCOMMAND	34

3.7.3 Related Events

The following table lists the collection events (CEIDs) which are relevant to remote control. For a more complete description of these events, refer to [Appendix B](#) or the description in this chapter.

Table 3-22 Remote Control CEIDS

Collection Event	CEID
OperatorCommand	4
StartCmd	14
StopCmd	15
PauseCmd	16
ResumeCmd	17
AbortCmd	18

3.8 Material Movement

Material movement on the Equipment consists of the following three board holding areas:

- Pre-dispense Area
- Dispensing Area
- Post-dispense Area

In order for processing to begin, a board must arrive from the upstream machine. The Equipment then conveys the board to the pre-dispense area, conveys it to the dispensing area, processes it, and then conveys the board to the post-dispense area. Before a new lot can be started, the board must be removed from the dispensing area. Collection events can be triggered only when a board arrives and leaves the dispensing area.

3.8.1 Related Variables

For a complete description of the variables relevant to material movement, refer to [Appendix A](#).

3.8.2 Related Collection Events

Many collection events relate directly to material movement or imply that material movement has taken place. For a complete listing of these collection events, refer to [Appendix B](#).

3.9 Equipment Terminal Services

The Equipment supports exchange of free text messages with the Host (SECS Stream 10). This Equipment accepts the following messages from the Host, and responds accordingly if the W-Bit is set to 1:

S10F3	/* Single Line Data */
S10F5	/* Multi-Line Data */
S10F9	/* Broadcast */

The message text will be displayed on the Equipment's CRT. Collection Event S10Ack (CEID 21) occurs once the Operator has acknowledged the message and an Event Report will be sent to the Host (if enabled).

The S10F3 and S10F9 are restricted to a single TEXT data item, but S10F5 can contain multiple TEXT data items. Each TEXT data item is limited to 160 characters.

If the Operator has not acknowledged an existing message when the Host sends another message, the new message will be displayed and the old one discarded.

The Host can send a message with a 0-length text to clear the Operator text display.

Also, the Equipment allows the Operator to send a single block message to the Host via S10F1. The maximum length of this text is 160 characters. The S10F2 response from the Host is ignored.

Fluidmove provides this functionality by allowing an operator to enter his message through the SECS/GEM Setup dialog box (Terminal tab), or via the SECS/GEM tab in the Run Window. The message will be sent when the Operator presses the Send button on screen.

Fluidmove also provides a Terminal Display to display text received from the Host from the SECS/GEM Setup dialog box (Terminal tab) or via the SECS/GEM tab in the Run Window.

Fluidmove notifies the Operator that a text message has arrived from the Host by blinking the GEM status bar at lower portion of screen. If the beep option has been selected a beep once every half a second will be used to catch Operator's attention. The Operator can then view the incoming message through the SECS/GEM Setup dialog box (Terminal tab), or via the SECS/GEM tab in the Run Window. In the same locations, there are provisions for the Operator to send a message to the Host.

3.10 Error Messages

The Equipment provides standard Stream 9 messages to report SECS-I errors. Refer to [5.7 SECS Error Messages](#) for detailed description of these messages:

S9F1	Unrecognized Device ID
S9F3	Unrecognized Stream
S9F5	Unrecognized Function
S9F7	Invalid Data
S9F9	Transaction Timeout
S9F11	Data Too Long

Fluidmove can reject a primary message received from the Host as incorrectly formatted for SECS-II (invalid data, or data too long).

3.11 Clock

The Equipment contains Clock/Calendar hardware, by which it knows the current date and time. This allows the following:

- The Host can send S2F31 to set the Equipment's Clock/Calendar hardware.
- The Host can send S2F17 to read the Equipment's Clock/Calendar hardware.
- The Operator can initiate a Date/Time request from the Host. This is done through the SECS/GEM Setup dialog box (Control tab).

3.11.1 Related Variables

Table 3-23 lists the relevant clock variables (SVs, ECs, or DVs). For a complete description of these variables, refer to [Appendix A](#).

Table 3-23 Clock Variables

Variable Name	VID
CLOCK	27

When time update messages from the Host are not arriving, a time update request to the Host shall be made approximately once per hour until the Host resumes time update messages.

3.12 Spooling

When the SECS link between the Host and the Equipment goes down (RTY error on the Equipment side), the Equipment will spool appropriate messages so that the Host can read them once the link comes back up (after a successful Connect Request transaction).

The Host can set spooling attributes on the Equipment by setting certain equipment constants with the S2F15/16 transaction.

The Host can define streams and functions of messages to be spooled through the S2F43/44 transaction. Stream one (S1Fx) messages are not eligible for spooling. The Host can also disable spooling for messages through this S2F43/44 transaction. Stream 9 messages are not spooled.

The Host may read spooled messages or purge the Equipment's spool through the S6F23/24 transaction.

3.12.1 A Word of Caution

If the Host does not intend to use the spooling features of the Equipment, the equipment constant ConfigSpool should be set to zero. Setting this EC to zero disables the spooling feature. If this is not set to zero, and the Host does not support spooling, the SECS connection with the Equipment will be crippled. This happens because of the following:

1. When spooling becomes active (transmission error), the Equipment will not send "Non-Stream 1" primary messages to the Host. That is, it will not send events, alarms, process programs, terminal display, etc.
2. When spooling becomes active, the ONLY way to deactivate it is to read (purge) or delete the spool from the Host. In complying with the GEM standard, the Equipment does not have the ability to reset its spooling state.
3. Therefore, if your Host does not support spooling and spooling becomes active, you will never again receive non stream 1 messages from the Equipment. If this occurs, you will need to use a Host simulator such as SECSIM to delete the spool.

3.12.2 Spooling Sequence

Messages are sent to the spool only if the Host has enabled these messages for spooling. This precondition will not be repeated throughout this section. Assume that the messages referred to in this section have been enabled for spooling.

While spooling is active, the Host may initiate primary messages and the Equipment will respond, if it is in the COMMUNICATING state.

Figure 3-7 and Table 3-24 describe the spooling sequence. Refer to Table 3-24 for definition of numbers used in the figure.

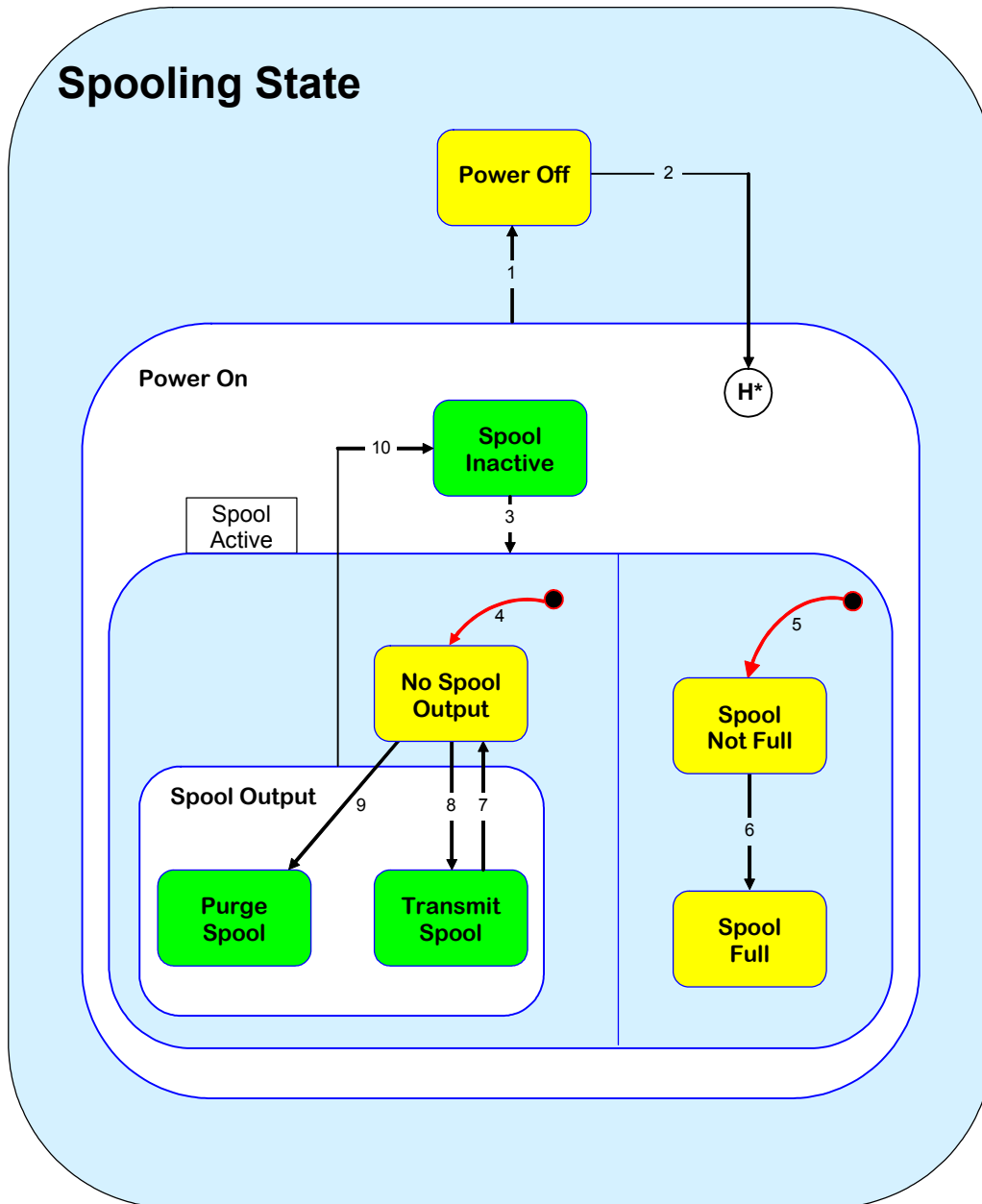

Figure 3-7 Spooling State Diagram

Table 3-24 Spooling State Transitions



NOTE The numbers in the # column refer to those in [Figure 3-7](#).

#	From	Trigger	To	Description
1	Power On	Equipment shutdown	Power Off	The Equipment may power off at any time.
2	Power Off	Equipment Startup	History* (Power On)	Equipment re-boots after a shutdown. Spooling will continue according to its state when the Equipment was powered off.
3	Spool Inactive	The Equipment experiences a transmission failure and the variable GemConfigSpool (VID 66) is set to "1" (enabled).	Spool Active	The Equipment will now start spooling any messages which have been defined by the Host. If the Host does not wish to implement Spooling, the EC GemConfigSpool should be set to "0" and the spool state will never become active.
4	Default	Entry into Spool Active	No Spool Output	No spooled messages are being read by the Host.
5	Default	Entry into Spool Active	Spool Not Full	The spool file has not yet filled up.
6	Spool Not Full	The Equipment's spool has reached capacity.	Spool Full	The Equipment will start to either discard new messages destined for the spool or overwrite the beginning of the spool, depending on the setting of GemOverWriteSpool (VID 62).
7	Transmit Spool	The Equipment has de-spoiled some messages, but not all have been sent to the Host.	No Spool Output	No spooled messages are being read by the Host.
8	No Spool Output	The Host has requested spooled messages to be sent by sending S6F23.	Transmit Spool	The Equipment will send messages according to the setting of GemMaxSpoolTransmit (VID 46). If GemMaxSpoolTransmit is zero, all messages will be sent, otherwise only the number of messages specified in this variable will be sent.
9	No Spool Output	The Host requests the Equipment to purge its spool.	Purge Spool	The Equipment will delete its spool.
10	Spool Output	Entire spool has either been read or purged by the Host.	Spool Inactive	The Equipment will continue normal SECS communicating.

3.12.2.1 Spooling Starts

When a transmission failure occurs, the first message sent to the spool is the event message GemSpoolingActivated. The next message sent to the spool is the message which caused the communications failure. Table 3-25 depicts the activity at the Equipment when spooling starts.

Table 3-25 Spooling Activity

#	Equipment Send Sequence	Spool Sequence	Description
1	S5F1 (Alarm Report 1)	S6F11 (Spool Activated Event Report)	Equipment attempts to send an alarm report to the Host, but experiences a transmit failure. The GemSpoolingActivated event (CEID 23) is sent to the spool. Variable GEMSPPOOLSTARTTIME (VID 52) is updated.
2		S5F1 (Alarm Report 1)	The Alarm Report message is sent to the spool.
3	S6F11 (Event Report 1)	S6F11 (Event Report 1)	The Equipment generates an Event Report and it is sent to the spool.
4	S5F1 (Alarm Report 2)	S5F1 (Alarm Report 2)	The Equipment generates an alarm report and it is sent to the spool.

3.12.2.2 Equipment Spools Messages

While spooling messages, the Equipment will increment the GEMSPPOOLCOUNTACTUAL and GEMSPPOOLCOUNTTOTAL status variables for each message spooled. Messages which require an inquire/grant scenario are spooled along with the inquire message as a single message. That is, if a multi-block S6F11 (Event Report) message is being sent to the Host and spooling is active, the S6F5 (inquire) as well as the S6F1 are sent to the spool and GEMSPPOOLCOUNTTOTAL and GEMSPPOOLCOUNTACTUAL are incremented by one.

The Equipment maintains two equipment constants which affect the spooling of messages. The first is CONFIGSPOOL. If this is set to zero, then spooling will never become active. If it is set to one, spooling will become active when a transmission failure occurs.

The EC OVERWRITESPOOL determines if the Equipment should over-write the oldest messages with new ones when the spool becomes full. If OVERWRITESPOOL is TRUE, old messages will be over-written with new ones. If FALSE, new messages will be discarded when the spool is full.

3.12.2.3 Host Reads Spooled Data

The Host can read spooled messages by sending the S6F23 message. Upon receipt of this message, the Equipment will reply and attempt to send spooled messages. Messages are sent in order of oldest to newest, with no priority given to a particular kind of message. The EC MAXSPOOLTRANSMIT determines the maximum number of spooled messages which are sent per S6F23 message received from the Host. If zero, all spooled messages are sent, if any other number, that number of messages are sent.

During the de-spooling of messages, the Equipment maintains only one outstanding Equipment-initiated transaction. The Equipment will wait for either a reply to the primary or a T3 timeout before starting another transaction. If the de-spooled message requires an inquire/grant scenario, the Equipment will initiate this transaction first. If the Host accepts the inquiry, the message is sent. If not, then the Equipment removes the message from the spool and discards it.

If a transmission failure occurs while attempting to send the spool, the event GemSpoolTransmitFailure is sent to the spool and spooling will remain active. While the spool is active, any new (spoolable) messages generated by the Equipment are also sent to the spool.

When the spool has been completely transmitted, the event GemSpoolingDeactivated is sent to the Host.

Instead of reading spooled messages, the Host can purge the spool by sending S6F23 with RSDC = 1. For details, refer to [4.2.80 “S6F23 – Request Spooled Data”](#).

3.12.3 Spool States

3.12.3.1 Power Off

The Equipment is completely shut down.

3.12.3.2 Power On

The Equipment is “on” and in a stable state. Table 3-26 describes the substates.

Table 3-26 Power On Spool Substates

Substate	Description
Spool Inactive	Spooling is not activated. This is either because GemConfigSpool is “0” (disabled) in which case, spooling will never be active, or because while GemConfigSpool is enabled (“1”), a RTY error has not occurred. In this state, no messages are sent to the spool. The Host may define or un-define messages eligible for spooling should the link go down.
Spool Active	<p>While GemConfigSpool is enabled (“1”), the Equipment has experienced a transmission failure (RTY error). Upon entry into this state, the first message sent to the spool is the GemSpoolingActivated event, assuming that this event is enabled and that spooling for the particular stream and function have been enabled. This message will enter the spool even before the message which originally caused the RTY error.</p> <p><u>Spool Not Full</u> - The file containing the spooled messages has not reached its capacity.</p> <p><u>Spool Full</u> - The file containing the spooled messages has reached its capacity.</p> <p><u>No Spool Output</u> - In this state, the Host is not reading or purging the Equipment’s spool.</p> <p><u>Spool Output</u> - This super-state contains the two sub-states in which the Equipment’s spool is either being read or purged by the Host.</p> <p><u>Purge Spool</u> - The Equipment is purging its spool, erasing all spooled messages.</p> <p><u>Transmit Spool</u> - The Equipment is transmitting spooled messages to the Host.</p>

3.12.4 Related Variables

The following table lists the variables (SVs, ECs, or DVs) which are relevant to spooling. For a more complete description of these variables, refer to [Appendix A](#).

Table 3-27 Spooling Variables

Variable Name	VID
MAXSPOOLTRANSMIT	46
SPOOLCOUNTACTUAL	48
SPOOLCOUNTTOTAL	49
SPOOLFULLTIME	50
SPOOLLOADSUBSTATE	51
SPOOLSTARTTIME	52
SPOOLSTATE	53
SPOOLUNLOADSUBSTATE	54
OVERWRITESPOOL	62
CONFIGSPOOL	63

3.12.5 Related Events

The following table lists the collection events (CEIDs) which are relevant to spooling. For a more complete description of these events, refer to [Appendix B](#) or the description in this chapter.

Table 3-28 Spooling CEIDS

Collection Event	CEID
GemSpoolingActivated	23
GemSpoolingDeactivated	24
GemSpoolTransmitFailure	25

4 SECS Message Detail

This section describes the basics of SML notation and lists each message sent or understood by the Equipment.

4.1 SML Notation

Message descriptions are shown using “SECS Message Language” (SML) notation. SML is a general notation developed by GW Associates for describing SECS messages. SML is similar to the notation used in the SECS Standards documents, but SML is a more precise and regular notation.

4.1.1 Data Item Format

In SML, the format for a Data Item is as follows:

< type [count] value >

The components of a Data Item are listed and described in Table 4-1.

Table 4-1 Components of a SML Data Item

Component	Description														
< >	Angle Brackets. Each Data Item is enclosed within angle brackets (“less than”, “greater than”). This notation implies that each Data Item has a Data Item Format and Data Item Length as required by SECS-II.														
type	<p>This specifies the SECS-II Data Item format. It will have one of the following values:</p> <table style="margin-left: auto; margin-right: auto;"> <tr> <td style="padding-right: 20px;">A</td> <td>ASCII</td> </tr> <tr> <td>B</td> <td>Binary</td> </tr> <tr> <td>J</td> <td>JIS-8</td> </tr> <tr> <td>I1, I2, I4, I8</td> <td>Signed Integers</td> </tr> <tr> <td>U1, U2, U4, U8</td> <td>Unsigned Integers</td> </tr> <tr> <td>F4, F8</td> <td>Floating Point</td> </tr> <tr> <td>BOOLEAN</td> <td>True/False</td> </tr> </table>	A	ASCII	B	Binary	J	JIS-8	I1, I2, I4, I8	Signed Integers	U1, U2, U4, U8	Unsigned Integers	F4, F8	Floating Point	BOOLEAN	True/False
A	ASCII														
B	Binary														
J	JIS-8														
I1, I2, I4, I8	Signed Integers														
U1, U2, U4, U8	Unsigned Integers														
F4, F8	Floating Point														
BOOLEAN	True/False														
count	<p>Count of the element values that make up the item. If present, the count is enclosed within square brackets “[]”. The count may be omitted, in which case the square brackets are also omitted.</p> <p>The “count” specifies the number of value elements in the Data Item Value. For String formats (ASCII, Binary, JIS-8), “count” specifies the number of characters in the string. For Numeric formats (I1, I2, I4, I8, U1, U2, U4, U8, F4, F8, BOOLEAN), “count” specifies the number of values in the array. For simple scalar numeric values, “count” is usually “1”. For LIST items, “count” specifies the number of items in the list.</p> <p>If “count” is omitted, then the length of the Data Item is implied by the value which follows. The “count” can range between known limits. It may be specified as minimum and maximum “counts”, separated by two dots. (For example, [0..40]).</p>														

Table 4-1 Components of a SML Data Item (continued)

Component	Description
<p>value</p>	<p>Value of a single item element. Values are shown in a notation that depends on the item type. For example, ASCII values are shown as characters enclosed in quotes, Unspecified Binary values are shown in hexadecimal.</p> <p>An ellipsis (...) is used to indicate additional elements may occur, as for example where substructures may repeat in a List structure.</p> <p>As an example, a two-byte unsigned integer Data Item with an array of three values 21, 22, and 23 is represented as:</p> <p style="text-align: center;"><U2 [3] 21 22 23></p> <p>Numeric values shown are considered decimal integers unless otherwise indicated. Negative values are shown with a leading minus sign “-“. Hexadecimal values are shown in C-Language convention, with a leading “0x”.</p> <p style="margin-left: 40px;">10 Decimal Ten</p> <p style="margin-left: 40px;">0x10 Hexadecimal 10</p> <p style="margin-left: 40px;">-10 Decimal Negative 10</p> <p>Where a value is not fixed, the SECS variable name is used directly. For Example:</p> <p style="text-align: center;"><A [6] SOFTREV></p>

4.1.2 Message Format

The format of a complete message is as follows:

SnFn W item .

The components of a complete message are described in Table 4-2.

Table 4-2 Components SML Notation

Component	Description
SnFn	The Stream and Function Codes, S1F1 for example.
W	The W-Bit, if set. Omitted if not set. If the W-Bit is optional, it is coded within brackets “[W]”.
item	A Data Item that is formatted as described in 4.1.1.
.	A period (.) ends the message definition.

For example, the S1F3 message might be described in SML as follows:

```
S1F3 W
  <L
    <U4 13>
    <U4 7>
  > .
```

4.2 SECS Messages

The following subsections describe the SECS messages sent or understood by the Equipment.

4.2.1 S1F1 - Are You There

S1F1 W. * H<->E

The Host may send this message to the Equipment at any time.

The Equipment sends this message periodically as a “heartbeat” to determine if the SECS link is operational.

The equipment constant ConfigConnect can be set to cause the Equipment to send S1F1 instead of S1F13 for Connect Request.

4.2.2 S1F2 - On Line Data (Equipment to Host)

S1F2 * H<-E
<L
 <A MDLN> * MDLN Model Number
 <A SOFTREV> * SOFTREV Software Revision
 > .

The Equipment reports its Model Number and Software Revision.

4.2.3 S1F2 - On Line Data (Host to Equipment)

S1F2 * H->E
<L> .

4.2.4 S1F3 - Selected Status Request

```
S1F3 W * H-> E
<L
  <U4 VID> * Variable ID
  ...
  > .
```

The Host requests status from the Equipment. The Host sends the VIDs of interest. Several VIDs can be specified if desired.

Normally, only VIDs of class SV (i.e. Status Variables) are used in this message. However, the Equipment allows the Host to use any VID of class DV, EC, or SV.

If S1F3 contains a zero-length list, then the Equipment will report all variables of class SV, in order by VID.

For compatibility with older Host implementations, the Equipment allows the following alternative form for this message using an array format:

```
S1F4 W * H->E
  <U4 VID...>.
```

4.2.5 S1F4 - Selected Status Data

```
S1F4 W * H<-E
<L
  <V> * Status Variable Value
  ...
  > .
```

The Equipment returns the Variable Values in the order requested by S1F3. If any VID specified in S1F3 is invalid, the corresponding V in S1F4 has the following error format:

```
<L> * V for Invalid VID
```

4.2.6 S1F11 - Status Variable Namelist Request

```
S1F11 W                                * H->E  
  
<L  
    <U4 VID>                            * Status Variable ID  
    ...  
> .
```

The Host format descriptions for the specified Variables. Several VIDs can be specified if desired.

Normally, only VIDs of class SV (i.e. Status Variables) are used in this message. However, any VID of class DV, EC, or SV can be used.

If S1F11 contains a zero-length list, then the Equipment will report all variables of class SV, in order by VID.

```
S1F11 W                                * H->E  
  
<L> .
```

4.2.7 S1F12 - Status Variable Namelist Reply

```
S1F12                                    * H<-E  
  
<L  
    <L [3]  
        <U4 VID>                            * Variable ID  
        <A SVNAME>                          * Status Variable Name  
        <A UNITS>                            * Units of Measure  
    ...  
> .
```

The Equipment returns the Variable descriptions in order requested in S1F11. If any VID specified in S1F11 is invalid, the corresponding List in S1F12 has the following error format:

```
<L>                                     * Instead of L [3]
```

4.2.8 S1F13 - Connect Request

The Equipment sends this message using the following format:

```
S1F13 W * H<-E
<L
  <A MDLN>
  <A SOFTREV>
  > .
```

The Host sends this message using the following format:

```
S1F13 W * H->E
<L> .
```

Either end of the link may send S1F13 as the first message to establish connection of the link.

Under the Equipment's initialization logic, the Equipment will always attempt to establish the link. If no Host acceptance reply is received, the Equipment sends this message periodically.

4.2.9 S1F14 - Connect Request Acknowledge

The Equipment sends this message using the following format:

```
S1F14 * H<-E
<L
  <B [1] 00> * COMMACK
  <L
    <A MDLN>
    <A SOFTREV>
    >
  > .
```

The Host sends this message using the following format:

```
S1F14 * H->E
<L
  <B [1] 00> * COMMACK
  <L>
  > .
```

The Equipment always sends the value 0x00 for COMMACK.

In messages received from the Host, COMMACK value 0x00 indicates acceptance of the connect request. Any other value indicates refusal.

4.2.10 S1F15 - Request Off-Line

S1F15 W . * H -> E

Host requests the Equipment to go Off-Line.

4.2.11 S1F16 - Off-Line Acknowledge

S1F16 * H <- E
<B [1] 0x00> . * OFLACK

Equipment Control State transits to Host Off-Line and sends this message in response to S1F15 primary. OFLACK is always zero.

4.2.12 S1F17 - Request On-Line

S1F17 W . * H -> E

Host requests the Equipment to go On-Line.

4.2.13 S1F18 - On-Line Acknowledge

S1F18 * H <- E
<B [1] ONLACK> .

Equipment responds to S1F17 primary in an attempt to go On-Line. Data item ONLACK indicates the success or failure of the attempt.

Table 4-3 On-Line Acknowledge

ONLACK	Description
0x00	OK. Equipment On-Line transition successful. Equipment Control State transits to either Local or Remote while On-Line as guided by the EC "GemOnlineSubstate".
0x01	On-Line not allowed.
0x02	Equipment already On-Line.

4.2.14 S1F65 - Connect Request

**NOTE**

This message is provided only for compatibility with Host computers which support an older version of GEM.

The equipment constant ConfigConnect can be set to cause the Equipment to send S1F65 instead of S1F13 for Connect Request.

The Equipment sends this message using the following format:

```
S1F65 W                               * H<-E
<L
  <A MDLN>
  <A SOFTREV>
  > .
```

Format 1: The Host sends this message using the following format:

```
S1F65 W                               * H->E
<L> .
```

Format 2: The Equipment also accepts the following form of this message:

```
S1F65 W .                             * H->E
```

Either end of the link may send S1F65 as the first message to establish connection of the link.

Under the Equipment's initialization logic, the Equipment will always attempt to establish the link. If no Host acceptance reply is received, the Equipment sends this message periodically.

4.2.15 S1F66 - Connect Request Acknowledge

**NOTE**

This message is provided only for compatibility with Host computers which support an older version of GEM.

If the Host sends S1F65, Format 1, the Equipment replies S1F66 using the following format:

```
S1F66                                * H<-E
<L
  <B [1] 00>                          * COMMACK
  <L
    <A MDLN>
    <A SOFTREV>
  >
> .
```

If the Host sends S1F65, format 2, the Equipment replies S1F66 using the following format:

```
S1F66                                * H<-E
<B [1] 00> .                          * COMMACK
```

The Host sends this message using the following format:

```
S1F66                                * H->E
<L
  <B [1] 00>
  <L>
> .
```

The Equipment also accepts the following form of this message.

```
S1F66                                * H->E
<B [1] 00> .                          * COMMACK
```

The Equipment always sends the value 0x00 for COMMACK.

In messages received from the Host, COMMACK value 0x00 indicates acceptance of the connect request. Any other values indicates refusal.

4.2.16 S2F13 - Equipment Constant Request

```
S2F13 W * H->E
<L
  <U4 VID> * Equipment Constant ID
  ...
  > .
```

The Host requests the VIDs of interest. Several VIDs can be specified if desired.

Normally, only VIDs of class EC (i.e. equipment constants) are used in this message. However, any VID of class DV, EC, or SV can be used.

If S2F13 contains a zero-length list, then the Equipment will report all variables of class EC, in order by VID.

For compatibility with older Host implementations, the Equipment allows the following alternative form for this message, using an array format:

```
S2F13 W * H->E
  <U4 VID VID ...> . * Equipment Constant ID
```

4.2.17 S2F14 - Equipment Constant Data

```
S2F14 * H<-E, Multiblock
<L
  <V> * Equipment Constant Value
  ...
  > .
```

The Equipment returns the equipment constants in the order requested in S2F13. If any VID specified in S2F13 is invalid, the corresponding V in S2F14 has the following error format:

```
<L> * V for Invalid VID
```

4.2.18 S2F15 - New Equipment Constant Send

```
S2F15 W * H->E
<L
  <L [2]
    <U4 VID> * Equipment Constant ID
    <V>
  >
  ...
> .
```

The Host sends new values for desired equipment constants. Several equipment constants can be specified if desired.

Only VIDs of class EC can be used in this message.

4.2.19 S2F16 - Equipment Constant Send Acknowledge

```
S2F16 * H<-E
<B [1] EAC> . * Equipment Acknowledge Code
```

Normal completion returns a zero (0) in EAC. If any ECID or ECV in S2F15 is invalid, then EAC contains a non-zero value, and the Equipment rejects the entire S2F15.

Table 4-4 EAC Values

EAC	Description
0x00	OK.
0x01	At least one ECID is invalid.
0x03	At least one ECV is out of range.

4.2.20 S2F17 - Date and Time Request

S2F17 W . * H<->E

The Host may send this message at any time to determine the Date and Time base that the Equipment is currently using.

The Equipment sends this message at the request of the Operator.

4.2.21 S2F18 - Date and Time Data

S2F18 * H<->E
* TIME - Date and Time
<A 'YYMMDDhhmmss'> . * If TIMEFORMAT = 0
- OR -
<A 'YYYYMMDDhhmmsscc'> . * If TIMEFORMAT = 1

This message contains the current Date and Time:

YY	Year (last two digits), 00 to 99	(TIMEFORMAT = 0)
YYYY	Year (all four digits)	(TIMEFORMAT = 1)
MM	Month, 01 to 12	
DD	Day, 01 to 31	
hh	Hours, 00 to 23	
mm	Minutes, 00 to 59	
ss	Seconds, 00 to 59	
cc	Centiseconds, 00 to 99	(TIMEFORMAT = 1)

When the Equipment receives a good S2F18, it sets its internal clock/calendar. When receiving S2F18, the Equipment will discard an invalid date or time. For example, if the date is good but the time is bad, the Equipment sets its date but not its time.

4.2.22 S2F23 - Trace Initialize Send

S2F23 W	* H->E
<L [5]	
<U4 TRID>	* Trace ID
<A 'hhmmss'>	* DSPER - Data Sample Period
<U4 TOTSMP>	* Total Number of Samples
<U4 REPGSZ>	* Reporting Group Size
<L	
<U4 SVID>	* Status Variable ID
...	
>	
> .	

The Host requests the Equipment to initiate a time driven trace operation.

The Equipment will send trace data using S6F1.

If TRID in S2F23 matches TRID of an existing trace, the existing trace operation is canceled, and replaced by the new one.

Up to four (4) separate TRIDs can be in operation simultaneously.

Within DSPER, must be a valid hour/minute/second format (hh 0-23, mm 0-59, ss 0-59), and cannot be 000000. The practical minimum value of DSPER is application dependent.

The Equipment will send the first S6F1 at one time period (DSPER * REPGSZ) after receiving S2F23.

If TOTSMP is zero, then S2F23 is a request to cancel an existing trace. Any trace with the specified TRID is canceled.

REPGSZ minimum value is 1. REPGSZ may not be so large that S6F1 would be a multi-block message. Typical value is 1.

Several SVIDs can be specified if desired. You must not specify so many SVIDs that S6F1 becomes a multi-block message.

Normally, only Variables of class SV are used in this message. However, any VID of class DV, EC, or SV can be used.

For compatibility with older Host implementations, the Equipment allows the following alternative form for this message, using an array format:

```

S2F23 W                                * H->E

<L [5]
  <U4 TRID>                             * Trace ID
  <A 'hhmmss'>                          * DSPER - Data Sample Period
  <U4 TOTSMP>                             * Total Number of Samples
  <U4 REPGSZ>                             * Reporting Group Size
  <U4 SVID SVID ...>                     * Status Variable ID array
  > .

```

4.2.23 S2F24 - Trace Initialize Acknowledge

```

S2F24                                * H<-E
  <B [1] TIAACK> .                  * TIAACK - Trace Init. Ack. Code

```

Table 4-5 Trace Initialize Acknowledge

TIAACK	Description
0x00	Normal. Everything correct.
0x03	Invalid period. DSPER is incorrect. The Equipment does not start the trace.

The Equipment does not signal an error if a Host error in S2F23 causes S6F1 to be multi-block. Instead, this Equipment sends multi-block S6F1 as requested by the Host.

This Equipment does not signal an error if the Host initiates more than four (4) simultaneous traces. The maximum number of traces supported depends on the size of the trace data, but is always at least 4.

4.2.24 S2F25 - Diagnostic Loopback Request

S2F25 W * H->E
<B ABS> . * ABS - Any Binary String

The Host sends an arbitrary binary string to test operation of the link.

The Equipment never sends this message to the Host.

4.2.25 S2F26 - Diagnostic Loopback Data

S2F26 * H<-E
<B ABS> . * ABS - Any Binary String

The Equipment “echoes” back the binary data from the Host’s S2F25.

4.2.26 S2F27 - Initiate Process Request

S2F27 [W] * H->E

<L [3] * Location (always ‘0’)
 <B LOC> * Process Program ID
 <A [1..12] PPID>
 <L [1] * Lot ID
 <A [1..16] MID>
 >
 > .

The Host sends this command to initiate a new lot for processing.

The Equipment ignores case when performing validity checks on the PPID string.

The Host may optionally set the W-Bit to “1” in S2F27. If so, the Equipment replies with S2F28.

PPID is the DOS 8.3 file name for the recipe. It should include the extension (RCP).

4.2.29 S2F30 - Equipment Constant Namelist Reply

```

S2F30                                * H<-E, Multiblock

<L
  <L [6]
    <U4 VID>                          * Equipment Constant ID
    <A ECNAME>                         * Equipment Constant Name
    <ECMIN>                             * ECV Minimum Value
    <ECMAX>                             * ECV Maximum Value
    <ECDEF>                             * ECV Default Value
    <A UNITS>                           * Units of Measure
  >
  ...
> .

```

The Equipment returns the equipment constant descriptions in the order requested in S2F29. If any VID specified in S2F29 is invalid, the corresponding List in S2F30 has the following error format:

```

<L>                                  * Instead of L [6]

```

4.2.30 S2F31 - Date and Time Send

```

S2F31 W                               * H->E
                                         * TIME - Date and Time

<A 'YYMMDDhhmmss'> .                 * If TIMEFORMAT = 0

- OR -

<A 'YYYYMMDDhhmmsscc'> .            * If TIMEFORMAT = 1

```

The Host commands the Equipment to set its Date and Time base to the specified value.

When the Equipment receives a good S2F31, it sets its internal clock/calendar. When receiving S2F31, the Equipment will discard an invalid date or time. For example, if the date is good but the time is bad, the Equipment sets its date but not its time.

4.2.31 S2F32 - Date and Time Acknowledge

```

S2F32                                * H<-E
  <B [1] TIACK> .                    * TIACK - Acknowledge Code

```

Table 4-7 TIACK

TIACK	Description
0x00	Normal. Everything correct.
0x01	Invalid Date and/or Time.

4.2.32 S2F33 - Define Report

```
S2F33 W * H->E, Multiblock
<L [2]
  <U4 DATAID> * DATAID
  <L
    <L [2]
      <U4 RPTID> * Report ID
      <L
        <U4 VID> * Variable ID
        ...
      >
    >
  >
  ...
  >
> .
```

The Host specifies one or more Report IDs, and defines which Variables should be included in each report.

If S2F33 is multi-block, the Host may optionally send the S2F39/S2F40 Inquire/Grant Transaction before sending S2F33, but this Equipment does not require it.

The Equipment ignores DATAID.

If the Equipment already contains existing Report Definitions, then this message can be used to download additional definitions for RPTIDs not yet defined. The Host cannot download a new Report Definition for a RPTID for which a Report Definition already exists in the Equipment. Instead, to change a Report Definition the Host must first delete the old Report Definition and then send a new Report Definition for that RPTID.

The Host can delete selected report definitions and associated links in the Equipment by using the following specifications in S2F33:

```
...
<L [2]
<U4 RPTID> * Report ID to delete
<L>
...
```

The Host can delete all report definitions and associated links in the Equipment by using the following special format:

```
S2F33 W * H->E
<L [2]
  <U4 DATAID> * DATAID
  <L>
  > .
```

4.2.33 S2F34 - Define Report Acknowledge

S2F34

<B [1] DRACK> .

* H<-E

* DRACK - Acknowledge Code

Normally, DRACK is zero. Any non-zero DRACK indicates the Equipment has rejected the entire S2F33 message.

Table 4-8 DRACK Values

DRACK	Description
0x00	OK.
0x02	Denied. Invalid format.
0x03	Denied. At least one RPTID already defined.
0x04	Denied. At least one VID does not exist.

4.2.34 S2F35 - Link Event Report

```
S2F35 W                                * H->E, Multiblock
<L [2]
  <U4 DATAID>                          * DATAID
  <L
    <L [2]
      <U4 CEID>                          * Collection Event ID
      <L
        <U4 RPTID>                       * Report ID
        ...
      >
    >
  ...
  >
> .
```

The Host links Report Ids to selected Collection Event Ids. The Specified CEIDs are initialized to “disabled”. See [4.2.36 S2F37](#) for enabling CEIDs.

If S2F35 is multi-block, the Host may optionally send the S2F39/S2F40 Inquire/Grant transaction before sending S2F35, but the Equipment does not require it.

The Equipment ignores DATAID.

The Host can eliminate all links for a CEID by sending the following format in S2F35 for that CEID:

```
...
<L [2]
<U4 CEID>                              * Collection Event ID
<L>
>
...
```

4.2.35 S2F36 - Link Event Report Acknowledge

S2F36
<B [1] LRACK> .

* H<-E
* LRACK - Acknowledge Code

Normally, LRACK is zero. Any non-zero LRACK indicates the Equipment has rejected the entire S2F35 message.

Table 4-9 LRACK Values

LRACK	Description
0x00	OK.
0x02	Denied. Invalid format.
0x03	Denied. At least one CEID link already defined.
0x04	Denied. At least one CEID does not exist.
0x05	Denied. At least one RPTID does not exist.
Other	Equipment has rejected the S2F35 message.

4.2.36 S2F37 - Enable/Disable Event Report

```

S2F37 W                                * H<-E
<L [2]
  <BOOLEAN CEED>                       * Coll. Event Enable
  <L
    <U4 CEID>                           * Collection Event ID
    ...
  >
> .

```

The Host enables reporting for a list of Collection Event IDs, or disables reporting for the list.

CEED is “True” to indicate Enabling, or “False” to indicate Disabling reporting for the specified CEIDs.

The Host can enable or disable all CEIDs by using the following special format:

```

S2F37 W                                * H->E
<L [2]
  <BOOLEAN CEED>                       * Coll. Event Enable
  <L>
> .

```

4.2.37 S2F38 - Enable/Disable Event Report Acknowledge

```

S2F38                                * H<-E
  <B [1] ERACK> .                    * ERACK - Acknowledge Code

```

Table 4-10 describes the ERACK values. Normally, ERACK is zero. Any non-zero ERACK indicates the Equipment has rejected the entire S2F37 message.

Table 4-10 ERACK Values

ERACK	Description
0x00	OK.
0x01	Denied. At least one CEID does not exist.

4.2.38 S2F39 - Multi-Block Inquire

S2F39 W * H->E
<L [2]
 <U4 DATAID> * DATAID
 <U4 DATALENGTH>
 > .

The Host may send this Inquire/Grant transaction preceding any multiblock S2F33 or S2F35. For this Equipment, this Inquire/Grant is optional. The Equipment accepts it, but ignores it, commits no resources, and initiates no Conversation Timeout. The Equipment accepts multiblock S2F33 or S2F35 even if not preceded by the Inquire/Grant.

4.2.39 S2F40 - Multi-Block Grant

S2F40 * H<-E
 <B [1] 00> . * GRANT

The Equipment always sends GRANT value "0".

4.2.40 S2F41 - Remote Command with Parameters

```

S2F41 [W] * H->E

<L [2]
  <A RCMD> * Remote command string
  <L
    <L [2]
      <A CPNAME> * Command Parameter Name
      <CPVAL> * Command Parameter Value
    >
  ...
  >
> .

```

The Host sends a command with parameters to the Equipment. If a command has no parameters, S2F41 has the following format:

```

S2F41 [W] * H->E

<L [2]
  <A RCMD> * Remote Command String
  <L>
  > .

```

The Equipment ignores case when performing validity checks on the RCMD and CPNAME strings. The ASCII strings described in may be sent in any combination of upper and lower case characters.

Table 4-11 ERACK Values

RCMD String	Function
"START"	Starts a Process Program.
"STOP"	Stops a running Process Program.
"ABORT"	Aborts a running Process Program.
"PAUSE"	Pauses a running Process Program.
"RESUME"	Resumes a paused Process Program.
"REMOTE"	Switches Equipment to "Remote" state.
"LOCAL"	Switches Equipment to "Local" state.

The Host may optionally set the W-Bit to "1" in S2F41. If so, the Equipment replies with S2F42.

4.2.41 S2F42 - Remote Command Acknowledge

```

S2F42                                * H<-E
<L [2]
  <B [1] HCAACK>                       * Host Command Ack. Code
  <L [n]
    <L [2]
      <A CPNAME>                         * Name of Parameter
      <B [1] CPACK>                       * Cmd Param Ack Code
    >
  ...
>
> .
  
```

Normal completion returns a zero (0) in HCAACK. The number of erroneous parameters “N” in S2F42 will be zero.

A non-zero value for HCAACK indicates that the Equipment has rejected the Remote Command. The number of erroneous parameters “n” can be zero or greater.

Table 4-12 HCAACK Values

HCAACK	Description
0x00	OK. All normal.
0x01	Invalid command. Equipment rejects command.
0x02	Cannot perform now. Equipment rejects command. Fluidmove is not in Run Window screen.
0x03	At least one parameter is invalid. Equipment rejects the command.
0x40	Control State is Local. Equipment rejects command.
0x41	Incorrect Process State for this command. Equipment rejects command.
0x42	Process Program contains an invalid format. Unable to load program.



NOTE Fluidmove is currently not returning the HCAACK rejection codes (upon successful completion HCAACK will still be returned as zero). To indicate command rejection, the RCMD string will be echoed back to the Host with no HCAACK value.

Table 4-13 CPACK Values

CPACK	Description
0x01	Invalid parameter name (CPNAME). The CPNAME is not a valid parameter for this command.
0x02	Illegal parameter value (CPVAL). The parameter value is out of range.
0x03	Illegal format for parameter (CPVAL). The value for this parameter does not use the correct SECS-II data item type.
0x40	Duplicate parameter name. This parameter name occurred at least twice in the S2F41 command.

4.2.42 S2F43 - Reset Spooling Streams and Functions

```
S2F43 W                                * H -> E
<L
  <L [2]
    <U1 STRID>                          * Message Stream
    <L
      <U1 FCNID>                        * Message Function
      ...
    >
  >
  ...
> .
```

The Host sends message to specify which messages the Equipment should spool in the event of a communications loss. When this message is received by the Equipment, all previous definitions of messages to spool are replaced.

The following version of S2F43 will enable spooling for all messages within the specified stream:

```
S2F43 W                                * H -> E
<L
  <L [2]
    <U1 STRID>                          * Message Stream
    <L>
  >
  ...
> .
```

To disable spooling of all messages, the following version of S2F43 may be used.

```
S2F43 W                                * H -> E
<L>.
```

Spooling is not allowed for even-numbered function messages (replies) or stream one messages.

4.2.43 S2F44 - Reset Spooling Acknowledge

The S2F44 message has two forms, depending on the return code in RSPACK. If there are no errors in S2F43, the format of S2F44 is as follows.

```

S2F44                                * H <- E

<L [2]
  <B [1] 00>                          * RSPACK
  <L>
> .
  
```

If S2F43 contains any errors, the Equipment will discard the entire S2F43, and return error information in S2F44, as follows:

```

S2F44                                * H <- E

<L [2]
  <B [1] 01>                          * RSPACK
  <L
    <L [3]
      <U1 STRID>                       * Msg String
      <B STRACK>                       * Stream Ack Code
      <L
        <U1 FCNID>                     * Msg Function
        ...
      >
    >
  >
  ...
> .
  
```

The RSPACK code indicates whether the Equipment accepted the S2F43 message:

Table 4-14 RSPACK Values

RSPACK	Description
0x00	Acknowledge, spooling setup accepted.
0x01	Spooling setup rejected. At least one message requested as spool-able could not be made so.

When errors exist in the request to set some messages as spool-able, the Equipment will return codes explaining the nature of the error. These codes are found in the STRACK data item.

Table 4-15 STRACK Values

STRACK	Description
0x01	Spooling not allowed for this stream. Spooling is never allowed for stream one.
0x04	Requested message is a secondary message and therefore ineligible for spooling.

4.2.44 S2F45 - Define Variable Limits Attributes

```

S2F45 W                                * H -> E
<L [2]
  <U4 DATAID>
  <L
    <L [2]
      <U4 VID>                        * Variable ID
      <L
        <L [2]
          <B [1] LIMITID>
          <L [2]
            <UPPERDB>
            <LOWERDB>
          >
        >
      >
    >
  >
  ...
  >
  ...
> .

```

With this message, the Host defines a set of limits for a single variable or a series of variables.

DATAID may be any value, and is ignored by the Equipment.

VID must specify the Variable ID of a Variable for which Limits Monitoring is allowed.

LIMITID must be between 0x01 and 0x07. It specifies one of the seven allowable limits for the variable.

UPPERDB and LOWERDB must match the value format of the specified variable

The Host may undefine all limits for all VIDs:

```
S2F45 W                                * H -> E  
  
<L [2]  
  <U4 DATAID>  
  <L>  
> .
```

The Host may undefine all limits for a specific VID:

```
S2F45 W                                * H -> E  
  
<L [2]  
  <U4 DATAID>  
  <L  
    <L [2]  
      <U4 VID>  
      <L>  
    >  
    ...  
  >  
> .
```

The Host may undefine a specific limit for a specific VID:

```
S2F45 W                                * H -> E  
  
<L [2]  
  <U4 DATAID>  
  <L  
    <L [2]  
      <U4 VID>  
      <L  
        <L [2]  
          <B [1] LIMITID>  
          <L>  
        >  
      >  
      ...  
    >  
    ...  
  >  
> .
```

4.2.45 S2F46 - Variable Limit Attribute Acknowledge

This message acknowledges the successful setting of limits as defined in the Host-generated S2F45.

```

S4F46                                * H <- E

<L [2]
  <B [1]                               * VLAACK
  <L>
> .

```

If any of the limits proposed in S4F45 are invalid, all limits for all variables in this message are rejected. The following message is sent in the event of an error:

```

S4F46                                * H <- E

<L [2]
  <B [1] VLAACK>
  <L
    <L [3]
      <U4 VID>
      <B [1] 0x00>          * LVACK
      <L [2]
        <B [1] LIMITID>
        <B [1] LIMITACK>
      >
    >
  ...
> .

```

Data item VLAACK reports to the Host the status of the request to define limits for the requested variables.

Table 4-16 VLAACK Values

VLAACK	Description
0x00	OK. Limits successfully defined.
0x01	Limit attribute definition error.

The LVACK data item gives information to the Host about the status of setting a specific variable when the request to set it is unsuccessful.

Table 4-17 LVACK Values

LIMIT-ACK	Description
0x01	Requested variable does not exist.
0x02	Variable is not eligible for limits definition.
0x03	Requested variable was repeated in request message.
0x04	Error in setting limit due to reason specified in LIMITACK.

The LIMITACK data item indicates the status of an attempt to set an individual limit for a variable.

Table 4-18 VLACK Values

VLACK	Description
0x01	LIMITID does not exist.
0x02	Requested UPPERDB is greater than LIMITMAX.
0x03	Requested LOWERDB is lower than LIMITMIN.
0x04	UPPERDB < LOWERDB.
0x05	Illegal format specified for UPPERDB or LOWERDB.

4.2.46 S2F47 - Variable Limit Attribute Request

```
S2F47 W                                * H -> E  
  
<L  
    <U4 VID>                            * Requested Variable ID  
    ...  
> .
```

The Host sends this message to the Equipment to request the limits attributes for specific variables. The Host may request the limits attributes for all defined variables with the following message.

```
S2F47 W                                * H -> E  
  
<L> .
```

In response to this message, the Equipment reports all limits attributes for all variables. If a variable is eligible for limits monitoring, but does not have any limits defined, it is not reported.

4.2.47 S2F48 - Variable Limit Attributes Send

```

S2F48                                * H <- E

<L
  <L [2]
    <U4 VID>                          * Variable ID
    <L [4]
      <A UNITS>                        * Units of Measure
      <LIMITMIN>                       * Minimum Limit
      <LIMITMAX>                       * Maximum Limit
      <L
        <L [3]
          <B [1] LIMITID>              * Limit ID
          <UPPERDB>                    * Upper Deadband
          <LOWERDB>                    * Lower Deadband
        >
      ...
    >
  >
  ...
> .

```

The Equipment sends this message in response to a Host S2F47 and reports the characteristics of limits for specified variables. In response to a request from the Host for all limits for all variables, only variables with limits defined are reported. If the Host requests specific variables which are not eligible for limits monitoring, the following message will be reported for that variable:

```

S2F48                                * H <- E

<L
  <L [2]
    <U4 VID>                          * Variable ID
    <L>                                * Not eligible for Limits
  >
  ...
> .

```

If the Host requests the limits for a specific variable which is eligible for limits monitoring but does not have any limits defined, this variable will be reported as follows:

```

S2F48                                     * H <- E

<L
  <L [2]
    <U4 VID>                             * Variable ID
    <L [4]
      <A UNITS>                           * Units of Measure
      <LIMITMIN>                          * Minimum Limit
      <LIMITMAX>                          * Maximum Limit
      <L>                                  * No Limits Defined
    >
  >
  ...
> .

```

4.2.48 S5F1 - Alarm Report

```

S5F1 [W]                                 * H<-E

<L [3]
  <B [1] ALCD>                            * ALCD - Alarm On/Off and Severity
  <U4 ALID>                                * ALID - Alarm ID
  <A [40] ALTX>                            * ALTX - Alarm Text
  > .

```

This message is the “normal” message that the Equipment uses to report alarms. In order for this message to be used, the equipment constant “ConfigAlarms” must be set to “0”. If “ConfigAlarms” is set to “0”, the Equipment sends S5F1 instead of the normal S5F73 Alarm Notification Send. The Equipment reports that an alarm condition has changed.

ALID identifies the Alarm.

The high-order bit of ALCD will be “1” if this alarm is currently On (Unsafe), or “0” if it is currently Off (Safe). The low-order seven bits of ALCD contain the severity code for this alarm.

ALTX contains up to 40 bytes of Alarm Text. Refer to [Appendix C](#) for a table of possible alarms.

Equipment constant “WBitS5” controls whether the Equipment sends S5F1 with W-Bit “1” (Reply Expected) or “0” (No Reply Expected).

For any invalid ALID specified in S5F5, the corresponding entry in S5F6 has the following special error format:

```
<L [3]
  <B> * ALCD - Alarm On/Off and Severity Code
  <U4 ALID> * Alarm ID
  <A> * ALT X - Alarm Text
>
```

If S5F5 specified all alarms, S5F6 reports alarms in order by alarm ID.

4.2.54 S5F7 - List Enabled Alarms Request

```
S5F7 W . * H->E
```

The Host requests the Equipment to send the current status of all Alarm IDs which are currently enabled (refer to [4.2.50 “S5F3 – Enable/Disable Alarm Send”](#)).

4.2.55 S5F8 - List Enabled Alarm Data

```
S5F8 * H<-E, Multiblock
<L
  <L [3]
    <B [1] ALCD> * ALCD - Alarm On/Off and Severity Code
    <U4 ALID> * Alarm ID
    <A ALT X> * ALT X - Alarm Text
  >
  ...
> .
```

The high-order bit of ALCD will be “1” if this alarm is currently On (Unsafe), or “0” if it is currently Off (Safe). The low-order seven bits of ALCD contain the severity code for this alarm.

S5F8 contains only those ALIDs which are currently enabled for reporting (refer to [4.2.50 “S5F3 – Enable/Disable Alarm Send”](#)).

S5F8 reports alarms in order by Alarm ID.

4.2.56 S5F71 - Alarm Report Block Send

```
S5F71 [W] * H<-E
<L [2]
  <U1 0> * ALPY Alarm Priority
  <L [1]
    <L [4]
      <U4 ALID> * ALID - Alarm ID
      <BOOLEAN ASTAT> * T = Alarm On, F = Alarm Off
      <U4 ASER> * ASER Alarm Serial Number
      <A [16] 'YYYYMMDDhhmmsscc'> * CLOCK
    >
  >
> .
```



NOTE

This message is provided only for compatibility with Host computers which support an older version of GEM.

If the equipment constant “ConfigAlarms” is set to “1”, the Equipment sends S5F71 instead of the normal S5F1 Alarm Notification Send.

The Equipment reports that an alarm condition has changed.

ALID identifies the Alarm.

ASTAT value is “True” (Non-zero) if this alarm is currently On (Unsafe), or “False” (Zero) if it is currently Off (Safe).

ASER (Alarm Serial Number) is assigned by the Equipment. Its value begins at “1” and is incremented by 1 for each alarm reported.

ALPY (Alarm Priority) is always zero.

CLOCK indicates the date and time of the alarm change.

Equipment constant “Wbits5” controls whether the Equipment sends S5F71 with W-bit “1” (Reply Expected) or “0” (No Reply Expected).

4.2.57 S5F72 - Alarm Report Block Acknowledge

S5F72 * H->E
<L> .

The Host acknowledges Alarm Report. This Equipment ignores the data portion of S5F72.

4.2.58 S5F73 - Alarm Report Block Acknowledge

S5F73 [W] * H<-E
<L [3]
<U4 ALID> * ALID - Alarm ID
<BOOLEAN ASTAT> * T = Alarm On, F = Alarm Off
<A [16] 'YYYYMMDDhhmmsscc'> * TIMESTAMP
> .



NOTE This message is provided only for compatibility with older Host computers which support GEM 3.1 (refer to [1.9.3 GEM Configuration](#)).

In order for this message to be used, the equipment constant “ConfigAlarms” must be set to “2”.

The Equipment reports that an alarm condition has changed.

ALID identifies the Alarm.

ASTAT value is “True” (Non-zero) if this alarm is currently On (Unsafe), or “False” (Zero) if it is currently Off (Safe).

TIMESTAMP indicates the date and time of the alarm change.

Equipment constant “WBitS5” controls whether the Equipment sends S5F73 with W-Bit “1” (Reply Expected) or “0” (No Reply Expected).

4.2.59 S5F74 - Alarm Notification Acknowledge

S5F74 * H->E
<B [1] ACK5> .

The Host acknowledges Alarm Report. This Equipment ignores ACKC5.

4.2.60 S6F1 - Trace Data Send

```
S6F1 [W] * H<-E
<L [4]
  <U4 TRID> * Trace ID
  <U4 SMPLN> * Sample Number
              * STIME - Sample Date/Time

  <A 'YYMMDDhhmmss'> * If TIMEFORMAT = 0
  • OR -
  <A 'YYYYMMDDhhmmsscc'> * If TIMEFORMAT = 1
  <L
    <V> * Variable Value
    ...
    >
  >.
```

The Equipment sends time driven trace data, as previously requested by the Host using S2F23.

TRID is the Trace ID as initiated by the Host.

SMPLN is the sample number. The first sample is "1", the next "2", and so on. If REPGSZ is greater than 1, SMPLN is the number of the last sample contained in this S6F1.

STIME is the date and time at which this sample was taken. If REPGSZ is greater than 1, STIME is the date and time of the last sample contained in this S6F1.

The V's appear in the same order they were specified in S2F23.

S6F1 is normally single block. However, if the Host erroneously initiates a multiblock trace using an incorrect S2F23, S6F1 may be multi-block. The Equipment never sends an Inquire/Grant message preceding S6F1.

Equipment constant "WBitS6" controls whether the Equipment sends S6F1 with W-Bit "1" (Reply Expected) or "0" (No Reply Expected).

4.2.61 S6F2 - Trace Data Acknowledge

```
S6F2 * H->E
  <B [1] 00> . * ACKC6
```

The Host acknowledges the data. The Equipment ignores ACKC6.

4.2.62 S6F3 - Annotated Event Report

```

S6F3 [W] * H<-E, Multiblock

<L [3]
  <U4 DATAID> * DATAID
  <U4 CEID> * Collection Event ID
  <L
    <L [2]
      <U4 DSID> * DSID=RPTID Report ID
      <L
        <U4 VID> * Variable ID
        <V> * Variable Value
        >
      ...
    >
  >
  ...
> .

```



NOTE

This message is provided only for compatibility with older Host computers which do not support GEM (refer to [1.9.3 GEM Configuration](#)).

If the equipment constant “ConfigEvents” is set to “0”, the Equipment sends S6F3 instead of the normal S6F13 Annotated Event Report.

A Collection Event has occurred at the Equipment. The Host has enabled Event Reporting for this CEID (refer to [4.2.36 “S2F37 – Enable/Disable Event Report”](#)). The Host has set the Equipment constant RpType to “True” (Annotated report format desired). The Equipment sends one or more Event Reports which the Host has previously linked to that CEID (refer to [4.2.35 “S2F36 – Link Event Report”](#)). Each report contains specific Variables which the Host has previously defined for that Report (See [4.2.32 “S2F33 – Define Report”](#)).

The Equipment generates a value for DATAID to uniquely identify this Conversation. If S6F3 is multiblock, the Equipment first sends the S6F5/S6F6 Inquire/Grant transaction, and DATAID in S6F3 will match DATAID in S6F5.

If the CEID is enabled, but no Reports are linked to this CEID, S6F3 has the following special format:

```

S6F3 [W] * H<-E

<L [3]
  <U4 DATAID> * DATAID
  <U4 CEID> * Collection Event ID
  <L>
  > .

```

Equipment constant “Wbits6” controls whether the Equipment sends S6F3 with W-Bit “1” (Reply Expected) or “0” (No Reply Expected).

4.2.66 S6F9 - Event Report



NOTE

This message is provided only for compatibility with older Host computers which do not support GEM. (Refer to [1.9.3 GEM Configuration](#).)

```
S6F9 [W] * H<-E, Multiblock

<L [4]
  <B [1] 00> * PFCD (always zero)
  <U4 DATAID> * DATAID
  <U4 CEID> * Collection Event ID
  <L
    <L [2]
      <U4 DSID> * DSID=RPTID Report ID
      <L
        <V> * Variable Value
        ...
      >
    >
  ...
  > .
```

If the equipment constant “ConfigEvents” is set to “0”, the Equipment sends S6F9 instead of the normal S6F11 Event Report.

An Event Report will be sent if a Collection Event has occurred at the Equipment. The Host has enabled Event Reporting for this CEID (refer to [4.2.36 “S2F37 – Enable/Disable Event Report”](#)). The Host has set the equipment constant “RpType” to “False” (normal report format desired). The Equipment sends one or more Event Reports which the Host has previously linked to that CEID (refer to [4.2.34 “S2F35 – Link Event Report”](#)). Each report contains specific Variables which the Host has previously defined for that Report (refer to [4.2.32 “S2F33 – Define Report”](#)).

The Equipment generates a value for DATAID to uniquely identify this Conversation. If S6F9 is multiblock, the Equipment first sends the S6F5/S6F6 Inquire/Grant transaction, and the DATAID in S6F9 will match DATAID in S6F5.

If the CEID is enabled, but no Reports are linked to this CEID, S6F9 has the following special format:

```
S6F9 [W] * H<-E

<L [4]
  <B [1] 00> * PFCD (always zero)
  <U4 DATAID> * DATAID
  <U4 CEID> * Collection Event ID
  <L>
  > .
```

Equipment constant “WBitS6” controls whether the Equipment sends S6F9 with W-Bit “1” (Reply Expected) or “0” (No Reply Expected).

4.2.67 S6F10 - Event Report Acknowledge

```
S6F10                                * H->E
  <B [1] 00> .                        * ACKC6
```

The Host acknowledges the Event Report. The Equipment ignores ACKC6.

4.2.68 S6F11 - Event Report Send

```
S6F11 W                                * H<-E
  <L [3]
    <U4 DATAID>                        * DATAID
    <U4 CEID>                            * Collection Event ID
    <L
      <L [2]
        <U4 RPTID>                        * Report ID
        <L
          <V>                            * Variable Value
          ...
          >
        >
      ...
      >
    > .
```

This message is the “normal” message that the Equipment uses to report events. In order for this message to be used, the equipment constant “ConfigEvents” must be set to “1”.

An Event Report will be sent if a Collection Event has occurred at the Equipment. The Host has enabled Event Reporting for this CEID (refer to [4.2.36 “S2F37 – Enable/Disable Event Report”](#)). The Host has set the equipment constant “RpType” to “False” (normal report format desired). The Equipment sends one or more Event Reports which the Host has previously linked to that CEID (refer to [4.2.34 “S2F35 – Link Event Report”](#)). Each report contains specific Variables which the Host has previously defined for that Report (refer to [4.2.32 “S2F33 – Define Report”](#)).

The Equipment generates a value for DATAID to uniquely identify this Conversation. If S6F11 is multiblock, the Equipment first sends the S6F5/S6F6 Inquire/Grant transaction, and the DATAID in S6F11 will match DATAID in S6F5.

If the CEID is enabled, but no Reports are linked to this CEID, S6F11 has the following special format:

```
S6F11 W                                * H<-E
  <L [3]
    <U4 DATAID>                        * DATAID
    <U4 CEID>                            * Collection Event ID
    <L>
  > .
```

4.2.69 S6F12 - Event Report Acknowledge

```
S6F12 * H->E
<B [1] 00> . * ACKC6
```

The Host acknowledges the Event Report. The Equipment ignores ACKC6.

4.2.70 S6F13 - Annotated Event Report Send

```
S6F13 W * H<-E, Multiblock
<L [3]
  <U4 DATAID> * DATAID
  <U4 CEID> * Collection Event ID
  <L
    <L [2] * Report ID
      <U4 RPTID>
      <L
        <L [2]
          <U4 VID> * Variable ID
          <V> * Variable Value
        >
      ...
    >
  >
  ...
> .
```



NOTE

This message is provided only for compatibility with older Host computers which support older versions of GEM (refer to [1.9.3 GEM Configuration](#)).

An Event Report will be sent if a Collection Event has occurred at the Equipment. The Host has enabled Event Reporting for this CEID (refer to [4.2.36 “S2F37 – Enable/Disable Event Report”](#)). The Host has set the equipment constant “RpType” to “True” (annotated report format desired). The equipment constant “ConfigEvents” has been set to 1. The Equipment sends one or more Event Reports which the Host has previously linked to that CEID (refer to [4.2.34 “S2F35 – Link Event Report”](#)). Each report contains specific Variables which the Host has previously defined for that Report (refer to [4.2.32 “S2F33 – Define Report”](#)).

The Equipment generates a value for DATAID to uniquely identify this Conversation. If S6F11 is multiblock, the Equipment first sends the S6F5/S6F6 Inquire/Grant transaction, and the DATAID in S6F11 will match DATAID in S6F5.

If the CEID is enabled, but no Reports are linked to this CEID, S6F11 has the following special format:

S6F13 W	* H->E
<L [3]	
<U4 DATAID>	* DATAID
<U4 CEID>	* Collection Event ID
<L>	
> .	

4.2.71 S6F14 - Annotated Event Report Acknowledge

S6F14	* H->E
<B [1] 00> .	* ACKC6

The Host acknowledges the Event Report. The Equipment ignore ACKC6.

4.2.72 S6F15 - Event Report Request

S6F15 W	* H->E
<U4 CEID> .	* Collection Event ID

The Host sends the CEID of interest, requesting normal format reports.

4.2.73 S6F16 - Event Report Data

S6F16		* H<-E, Multiblock
<L [3]		
<U4 DATAID>		* DATAID
<U4 CEID>		* Collection Event ID
<L		
<L [2]		
<U4 RPTID>		* Report ID
<L		
<V>		* Variable Value
...		
>		
>		
...		
>		
>		
>		

The Equipment sends one or more Event Reports which the Host has previously linked to that CEID (refer to [4.2.34 “S2F35 – Link Event Report”](#)). Each report contains specific Variables which the Host has previously defined for that Report (refer to [4.2.32 “S2F33 – Define Report”](#)).

This message occurs whether or not the Host has enabled Event Reporting for this CEID (refer to [4.2.36 “S2F37 – Enable/Disable Event Report”](#)), and regardless of how the Host has set the equipment constant “RpType” (report format).

The Equipment generates a meaningless value for DATAID.

CEID contains the CEID specified in S6F15.

If the CEID specified in S6F15 is invalid, or if no reports are linked to this CEID, this message has the following special format:

S6F16		* H<-E, Multiblock
<L [3]		
<U4 DATAID>		* DATAID
<U4 CEID>		* Collection Event ID
<L>		
>		

4.2.74 S6F17 - Annotated Event Report Request

S6F17 W * H->E
<U4 CEID> . * Collection Event ID

The Host sends the CEID of interest, requesting annotated format reports.

4.2.75 S6F18 - Annotated Event Report Data

S6F18 * H<-E
<L [3] * DATAID
 <U4 DATAID> * DATAID
 <U4 CEID> * Collection Event ID
 <L
 <L [2] * Report ID
 <U4 RPTID> * Report ID
 <L
 <L [2] * Variable ID
 <U4 VID> * Variable ID
 <V> * Variable Value
 >
 ...
 >
 >
 ...
 >
 > .

The Equipment sends one or more Event Reports which the Host has previously linked to that CEID (refer to [4.2.34 “S2F35 – Link Event Report”](#)). Each report contains specific Variables which the Host has previously defined for that Report (refer to [4.2.32 “S2F33 – Define Report”](#)).

This message occurs whether or not the Host has enabled Event Reporting for this CEID (refer to [4.2.36 “S2F37 – Enable/Disable Event Report”](#)), and regardless of how the Host has set up the equipment constant “RpType” (report format).

The Equipment generates a meaningless value for DATAID.

CEID contains the CEID specified in S6F17.

If the CEID specified in S6F17 is invalid, or if no reports are linked to this CEID, this message has the following format:

```
S6F18                                * H<-E, Multiblock
<L [3]
  <U4 DATAID>                        * DATAID
  <U4 CEID>                            * Collection Event ID
  <L>
  > .
```

4.2.76 S6F19 - Request Report Request

```
S6F19 W                                * H->E
  <U4 RPTID> .                          * Report ID
```

The Host requests a Report for the specified RPTID.

4.2.77 S6F20 - Request Report Data

```
S6F20                                * H<-E, Multiblock
<L
  <V>
  ...
  > .
```

The Equipment sends the Report.

If no report is defined for the RPTID in S6F19, S6F20 has the following special error format:

```
S6F20                                * H<-E
<L> .
```

4.2.78 S6F21 - Request Annotated Report Request

```
S6F21 W                                * H->E
  <U4 RPTID> .                          * Report ID
```

The Host requests an Annotated Report for the specified RPTID.

4.2.79 S6F22 - Request Annotated Report Data

```
S6F22                                * H<-E, Multiblock
<L
  <L [2]
    <U4 VID>                          * VID - Variable ID
    <V>
    >
  ...
  > .
```

The Equipment sends the Annotated Report.

If no Report is defined for the RPTID in S6F21, S6F22 has the following special error format:

```
S6F22                                * H<-E
<L> .
```

4.2.80 S6F23 - Request Spooled Data

```
S6F23 W                               * H -> E
  <U1 RSDC> .
```

The Host sends this message to start the transfer of spooled messages from the Equipment to the Host, or to delete the contents of the spool file, depending on the value of RSDC.

When the Host requests the spooled messages (RSDC is zero), the Equipment will send messages according to EC "MaxSpoolTransmit". All messages are sent from oldest to newest, and once the message is successfully sent, it is removed from the spool. If MaxSpoolTransmit is zero, all messages will be sent one at a time until the last message has been delivered. If MaxSpoolTransmit is set to a non-zero value, the Equipment will send the lesser of MaxSpoolTransmit or messages left in spool. If in this case the Equipment sends MaxSpoolTransmit messages, and messages remain in the spool, the Equipment will wait for another S6F23 to deliver the next messages.

If the Host sends S6F23 with RSDC set to one, this will be interpreted by the Equipment as a request to purge the spool.

Table 4-22 RSDC

RSDC	Description
0	Transmit spooled messages.
1	Purge spooled messages.

4.2.81 S6F24 - Request Spooled Data Acknowledge

S6F24 * H <- E
 <B [1] RSDA> .

Equipment acknowledges the Host's request to either purge spooled messages or send spooled messages to the Host.

Table 4-23 RSDA Values

RSDA	Description
0x00	Normal. Equipment will start to send spooled data or optionally purge the spool. Action performed will depend on value for RSDC in S6F23.
0x02	Denied. Spooled data does not exist.

4.2.82 S7F1 - Process Program Load Inquire

S7F1 W * H<->E
 <L [2]
 <A PPID> * Process Program ID
 <U4 LENGTH> * Length of text
 > .

PPID should be the recipe file name and should include the extension RCP.

The Sender requests permission to send a Process Program. The Process Program may be either a Load Recipe or Process Recipe.

The Equipment always sends this Inquire/Grant transaction before sending any multi-block S7F3. LENGTH specifies the number of bytes in the following S7F3 message, excluding SECS-I block-length bytes, block headers, and checksums.

For Host-to-Equipment transfers, this Inquire/Grant is optional. The Equipment accepts it, but ignores it, commits no resources, and initiates no Conversation timeout. The Equipment will accept a multi-block S7F3 even if not preceded by the Inquire/Grant.

4.2.83 S7F2 - Process Program Load Grant

S7F2
<B [1] 00> .

* H<->E
* PPGNT

The Receiver grants permission to send a Process Program. The Receiver sends PPGNT value 0x00 to indicate it will accept the Process Program, and the Sender should send S7F3. If the Receiver sends any other value in S7F2, it refuses the Grant, and the Sender should not send S7F3.

The Process Program may be either a Load Recipe, Process Recipe, or Parameter Table.

When the Equipment sends S7F2, PPGNT may contain the following codes:

Table 4-24 S7F2 PPGNT Values

PPGNT	Description
0x00	Normal. Permission granted.

When the Host sends S7F2, the Equipment interprets PPGNT as follows:

Table 4-25 S7F2 PPGNT Interpretations

PPGNT	Description
0x00	Normal. The Equipment sends S7F3.
Other	Refusal. The Equipment does not send S7F3 and the upload operation fails.

4.2.84 S7F3 - Process Program Send

S7F3 W * H<->E, Multiblock

<L [2]

 <A PPID> * PPID - Process Program ID

 <A PPBODY> * PPBODY – Process Program Body

PPID is the recipe file name and should include the extension RCP.

Send an Unformatted Process Program. Before sending a multi-block S7F3, the Equipment always first sends the S7F1/S7F2 Inquire/Grant transaction. The Host may send S7F1/S7F2 before sending S7F3. The Equipment accepts it, but does not require it.

4.2.85 S7F4 - Process Program Acknowledge

S7F4 * H<->E

<B [1] ACKC7> . * ACKC7

The Receiver acknowledges the receipt of the Process Program. If the transfer succeeds, ACKC7 will contain 0x00, and the Receiver stores the new Process Program into its library. Any previous Process Program with the same PPID is deleted. Any non-zero ACKC7 indicates refusal of the Process Program.

When the Equipment sends S7F4, ACKC7 may contain the following codes. Any non-zero code indicates that S7F3 has not changed the Equipment Library.

Table 4-26 S7F4 ACKC7 Values

ACKC7	Description
0x00	Normal. Process Program Accepted and stored into Library.
0x01	Permission Not Granted. Insufficient space in Library.
0x40	Process Program Format Error.
0x41	Process Program Data Error (Verify Failed).

When the Host sends S7F4, the Equipment interprets ACKC7 as follows:

Table 4-27 S7F4 ACKC7 Interpretations

ACKC7	Description
0x00	Normal.
Other	Refusal. The upload operation fails.

4.2.86 S7F5 - Process Program Request

S7F5 W * H<->E
 <A PPID> . * Process Program ID

PPID is the recipe file name and should include the extension RCP.

Request the other end of the link to send a specified Process Program from its library.

4.2.87 S7F6 - Process Program Data

S7F6 * H<->E, Multiblock
 <L [2]
 <A PPID> * Process Program ID
 <A PPBODY> * PPBODY - Process Program Body

PPID is the recipe file name and should include the extension RCP.

Send the requested Process Program.

If the specified PPID is not found in the library, S7F6 has the following special format:

S7F6 * H<->E
 <L> .

If the Equipment receives S7F6 and cannot store the Process Program in its library, the CEID BadDownload is signaled, with PPChangeName set to the PPID of the requested Process Program. This occurs if the received S7F6 is of the special “not found” form, if the S7F6 message is not in the expected format, or if an error is detected in PPBODY (for example, a parameter out of range).

4.2.88 S7F17 - Process Program Delete

S7F17 W * H->E
<L
 <A PPID> * Process Program ID
 ...
 > .

PPID is the recipe file name and should include the extension RCP.

The Host deletes one or more Process Programs from the Equipment library.

If S7F17 contains a zero-length List, the entire library is deleted.

4.2.89 S7F18 - Process Program Delete Acknowledge

S7F18 * H<-E
 <B [1] ACKC7> . * ACKC7 - Acknowledge Code

The Equipment acknowledges the Process Program delete.

Table 4-28 S7F18 ACKC7 Values

ACKC7	Description
0x00	Normal. All specified PPIDs have been deleted.
0x04	Error: At least one specified PPID was not found. However, correct PPIDs have been deleted from the Equipment Library.

4.2.90 S7F19 - Process Program Directory Request

S7F19 W . * H->E

The PPIDs returned are the recipe file names and should include the extension RCP.

The Host requests a directory of the Process Programs currently in the Equipment library.

4.2.91 S7F20 - Process Program Directory

S7F20 * H<-E
<L * Process Program ID
 <A PPID>
 ...
> .

The Equipment sends a directory of its Process Program library. If the library is empty, the list will be zero length.

4.2.92 S9F1 - Unrecognized Device ID

S9F1 * H<-E
<B [10] MHEAD> . * MHEAD - Header of bad msg

4.2.93 S9F3 - Unrecognized Stream

S9F3 * H<-E
<B [10] MHEAD> . * MHEAD - Header of bad msg

4.2.94 S9F5 - Unrecognized Function

S9F5 * H<-E
<B [10] MHEAD> . * MHEAD - Header of bad msg

5 SECS Scenarios

Unless otherwise noted in this section, the Communications State is “Communicating” and the Control state is either “On-Line/Local” or “On-Line/Remote”.

5.1 Equipment Communications

5.1.1 Equipment Establishes Communications

Assumption: Equipment’s Communication state is “Enabled/Not Communicating”.

Table 5-1 SECS Messages Equipment Establishes Communications

Step	SECS Message	Description
1.	H <- E S1F13 W	Equipment attempts to send Establish Communications Request.
2.		If the send is not successful, or if no reply is received from the Host, wait “ESTABLISHCOMMUNICATIONSTIMER” seconds, then go to Step 1.
3.	H -> E S1F14	The Host responds with Establish Communications Acknowledge. If COMMACK in this message is non-zero, wait “ESTABLISHCOMMUNICATIONSTIMER” seconds, then go to Step 1. If COMMACK is zero, proceed to the next step.
4.		Communications is successfully established. The Equipment changes its communication state to Communicating. Normal SECS message processing begins.

5.1.2 Host Establishes Communications

Assumption: Equipment's Communication state is either "Enabled/Not Communicating" or "Enabled/Communicating".

Table 5-2 SECS Messages Host Establishes Communications

Step	SECS Message	Description
1.	H -> E S1F13 W	Host sends Establish Communications Request.
2.	H <- E S1F14	The Equipment responds with Establish Communications Acknowledge, with COMMACK set to zero. After this message is successfully sent, communications is established. If the current communication state is "Not Communicating", the Equipment changes its communication state to "Communicating". If the state is "Communicating", no change in communication state occurs. In either case, subsequently received messages are processed normally.

5.1.3 Simultaneous Establish Communications

Assumption: Equipment's Communication state is "Enabled/Not Communicating".

Table 5-3 SECS Messages Simultaneous Establish Communications

Step	SECS Message	Description
1.	H <- E S1F13 W	Equipment sends Establish Communications Request.
2.	H -> E S1F13 W	Host sends Establish Communications Request.
3.	H <- E S1F14	The Equipment responds with Establish Communications Acknowledge, with COMMACK set to zero. After this message is successfully sent, communications is established. The Equipment changes its communication state to Communicating.
4.	H -> E S1F14	The Host responds with Establish Communications Acknowledge, with COMMACK set to zero. This step could occur before Step 3, in which case communications would be established at this step.

5.1.4 Losing Connection, Re-Connecting

Table 5-4 SECS Messages Losing Connection, Re-Connecting

Step	SECS Message	Description
1.	H <- E SxFy	Any Message. The Equipment encounters SECS block transmission errors while attempting to send a message to the Host., and reaches its Retry Limit (RTY). The Equipment considers the SECS link as disconnected. Spooling will become Active if enabled.
2.	H <-E S1F13 W	Connect Request. The Equipment attempts to re-establish the link.
3.		If the send is not successful, or if no reply is received from the Host, the Equipment waits for "EstablishCommunicationsTimer" seconds and then goes back to Step 2.
4.	H -> E S1F14	The Host acknowledges, sending COMMACK of "0". The link is now re-connected.

5.1.5 Heartbeat

Table 5-5 SECS Messages Heartbeat

Step	SECS Message	Description
1.	H <- E S1F1 W	Are You There. The Equipment sends this message periodically to determine if the SECS link is still intact.
2.	H -> E S1F2	On Line Data. The Host replies. The Equipment knows that the link is still intact.

5.2 Data Collection

5.2.1 Host Initializes Event Reporting

Table 5-6 SECS Messages Host Initializes Event Reporting

Step	SECS Message	Description
1.	H -> E S2F37 W	Disable Event Reports. The Host disables reporting for all Collection Events. S2F37 W <L [2] <BOOLEAN F> <L> > .
2.	H <- E S2F38	The Equipment acknowledges. Temporarily, the Equipment will make no event reports.
3.	H ->E S2F33 W	Define Report. The Host erases all previous report definitions and links: S2F33 W <L [2] <U4 DATAID> <L> > .
4.	H <- E S2F34	The Equipment acknowledges.
5.	H -> E S2F33 W	Define Report. The Host sends report definitions.
6.	H <-E S2F34	The Equipment acknowledges.
7.	H -> E S2F35 W	Link Events/Reports. The Host links reports to the desired Collection Events. Linked Reports are initially “disabled”.
8.	H <- E S2F36	The Equipment acknowledges.
9.	H -> E S2F15 W	Equipment constant “Send”. The Host sets equipment constant “RpType” to indicate whether event reports should be in “Normal” or “Annotated” format.
10.	H <- E S2F16	The Equipment acknowledges.
11.	H -> E S2F37 W	Enable event reports. The Host enables reporting for desired collection events.
12.	H <- E S2F38	The Equipment acknowledges. From this point on, the Equipment will report events as they occur.

5.2.2 Equipment Reports Event

Table 5-7 SECS Messages Equipment Reports Event

Step	SECS Message	Description
1.		The Equipment recognizes that an event has occurred. The Host has enabled reporting for the CEID, and possibly has defined one or more Reports and linked them to the CEID. The equipment constant "RpType" is set to "False", requesting normal reports.
2.	H <- E S6F5 W	Inquire. If S6F13 will be multi-block, the Equipment first sends this Inquire to request permission. If S6F11 is single-block, skip this and the next step.
3.	H -> E S6F6	Grant. The Host grants permission to send multi-block Event Report. If GRANT6 is non-zero, this scenario fails here, and the event data is discarded.
4.	H <- E S6F11 W	The Equipment sends Event reports for the CEID that occurred.
5.	H -> E S6F12	The Host acknowledges the report.

5.2.3 Equipment Reports Annotated Event

Table 5-8 SECS Messages Equipment Reports Annotated Event

Step	SECS Message	Description
1.		The Equipment recognizes that an event has occurred. The Host has enabled reporting for the CEID, and possibly has defined one or more Reports and linked them to the CEID. The equipment constant "RpType" is set to "True", requesting Annotated reports.
2.	H <- E S6F5 W	Inquire. If S6F13 will be multi-block, the Equipment first sends this Inquire to request permission. If S6F13 is single-block, skip this and the next step.
3.	H -> E S6F6	Grant. The Host grants permission to send multi-block Event Report. If GRANT6 is non-zero, this scenario fails here, and the event data is discarded.
4.	H <- E S6F13 W	The Equipment sends annotated Event Reports for the CEID that occurred.
5.	H -> E S6F14	The Host acknowledges the report.



NOTE In all other scenarios in which Event Reports occur, the Events or Annotated Events are shown in abbreviated form (S6F11/S6F12 only). The complete Event Report Scenarios are shown here.

5.2.4 Host Initiates Trace

Table 5-9 SECS Messages Host Initiates Trace

Step	SECS Message	Description
1.	H -> E S2F23 W	The Host initiates a trace.
2.	H <- E S2F24	The Equipment acknowledges the trace request. If the data in S2F23 is not valid, the acknowledge code in this message is non-zero and the scenario ends. Otherwise, the following steps are done "TOTSMP" times, where TOTSMP is the total number of samples to be done.
3.		The Equipment waits "DSPER" (data sample period). While waiting, the Equipment continues to operate normally, responding to any SECS messages that may be received, etc. After the wait is finished, the values of the variable(s) to be traced are obtained and saved. If "REPGSZ" samples have been saved, or if this is the last sample, do the following steps.
4.	H <- E S6F1 W	The Equipment sends trace data.
5.	H -> E S6F2	If the S6F1 has its W-bit set to 1, the Host acknowledges the trace data.
6.		If this is the last sample, the Equipment terminates this trace and the scenario ends. Otherwise, go back to the beginning of Step 3.

5.2.5 Host Terminates Trace

Assumption: The Host started a Trace report as in the above scenario.

Table 5-10 SECS Messages Host Terminates Trace

Step	SECS Message	Description
1.	H -> E S2F23 W	The Host initiates a trace, with the same trace ID as the currently running trace, and with TOTSMP (number of samples) set to "0".
2.	H <- E S2F24	The Equipment acknowledges the trace request. If the data in S2F23 is valid, the Equipment terminates the trace.
3.		If the Equipment has saved trace data that has not yet been sent to the Host, it discards the saved data.

5.2.6 Host Requests Status

Table 5-11 SECS Messages Host Requests Status

Step	SECS Message	Description
1.	H -> E S1F3 W	Discrete Variable Request. The Host requests the VIDs of interest.
2.	H <- E S1F4	The Equipment sends the Variable values.

5.2.7 Host Defines Limits

Table 5-12 SECS Messages Host Defines Limits

Step	SECS Message	Description
1.	H -> E S2F45 W	Host defines new variable limits attributes.
2.	H <- E S2F46	Equipment accepts new limits definitions, and responds with VLAACK = 0x00.

5.2.8 Host Queries Defined Limits

Table 5-13 SECS Messages Host Queries Defined Limits

Step	SECS Message	Description
1.	H -> E S2F47 W	Host requests listing of defined limits. This request may be for limits of individual variables listed in this message, or if this message is an empty list, all limits will be replied.
2.	H <- E S2F48	Equipment sends limits values as required.

5.2.9 Host Requests Report by CEID

Table 5-14 SECS Messages Host Requests Report by CEID

Step	SECS Message	Description
1.	H -> E S6F15 W	Request Event Report. The Host requests a report for the specified CEID. In this way, the Host requests the Equipment to "pretend" that the specified CEID has occurred.
2.	H <- E S6F16	The Equipment sends reports linked to that CEID.

5.2.10 Host Requests Annotated Report by CEID

Table 5-15 SECS Messages Host Requests Annotated Report by CEID

Step	SECS Message	Description
1.	H -> E S6F17 W	Request Annotated Event Report. The Host requests a report for the specified CEID. In this way, the Host requests the Equipment to “pretend” that the specified CEID has occurred.
2.	H <- E S6F18	The Equipment sends annotated reports linked to that CEID.

5.2.11 Host Requests Report by RPTID

Table 5-16 SECS Messages Host Requests Report by RPTID

Step	SECS Message	Description
1.	H -> E S6F19 W	Request Report. The Host requests a report for the specified RPTID.
2.	H <- E S6F20	The Equipment sends the report.

5.2.12 Host Requests Annotated Report by RPTID

Table 5-17 SECS Messages Host Requests Annotated Report by RPTID

Step	SECS Message	Description
1.	H -> E S6F21 W	Request Annotated Report. The Host requests an annotated report for the specified RPTID.
2.	H <- E S6F22	The Equipment sends the annotated report.

5.2.13 Are You There

Table 5-18 SECS Messages Are You There

Step	SECS Message	Description
1.	H -> E S1F1 W	Are You There. The Host sends this simple message.
2.	H <- E S1F2	The Equipment reports its MDLN and SOFTREV.

5.2.14 Host Reads Equipment Constants

Table 5-19 SECS Messages Host Reads Equipment Constants

Step	SECS Message	Description
1.	H -> E S2F13 W	Host requests the values of one or more equipment constants.
2.	H <- E S2F14	The Equipment responds with the values of the requested equipment constants.

5.2.15 Host Sets Equipment Constants

Table 5-20 SECS Messages Host Sets Equipment Constants

Step	SECS Message	Description
1.	H -> E S2F15 W	Host sends new values for one or more equipment constants.
2.	H <- E S2F16	If all new values are valid, the Equipment saves the new values and sends this message with an acknowledge code of "0". If one or more new values are not valid, no equipment constants are changed and the acknowledge code in this message is non-zero.

5.3 Alarms

5.3.1 Equipment Reports Alarm

Table 5-21 SECS Messages Equipment Reports Alarm

Step	SECS Message	Description
1.	H <- E S5F1 [W]	If reporting for this alarm ID is disabled, skip this and the following step. Otherwise send the alarm. The equipment constant "WBitS5" determines whether the W-bit is "0" or "1" in this message.
2.	H -> E S5F2	If the W-bit in S5F1 is 1, the Host acknowledges the alarm report. Otherwise, skip this step.
3.	H <- E S6F11 W	If the event ID associated with this alarm state is enabled, send the Event Report. Otherwise, the scenario ends.
4.	H -> E S6F12	The Host acknowledges the Event Report.

5.3.2 Host Enables/Disables Alarms

Table 5-22 SECS Messages Host Enables/Disables Alarms

Step	SECS Message	Description
1.	H -> E S5F3 [W]	The Host specifies ALIDs to be enabled or disabled.
2.	H <- E S5F4	If the W-bit in S5F3 is 1, the Equipment acknowledges.

5.3.3 Host Requests Alarms

Table 5-23 SECS Messages Host Requests Alarms

Step	SECS Message	Description
1.	H -> E S5F5 W	The Host requests whether specified ALIDs are "on" or "off".
2.	H <- E S5F6	The Equipment sends Alarm status.

5.3.4 Alarm Report (GEM, Ver 3.1 Compatibility)



NOTE This scenario is provided only for compatibility with Host computers which support GEM, Version 3.1.

Table 5-24 SECS Messages Alarm Report (GEM, Ver 3.1 Compatibility)

Step	SECS Message	Description
1.		The equipment constant "ConfigAlarms" is set to 2 for non-GEM compatibility. The Equipment recognizes that an alarm condition has gone "on" (i.e. has become Unsafe).
2.	H <- E S5F73 [W]	The Equipment reports the Alarm going on. The high-order bit of ALCD is "1".
3.	H -> E S5F74	If the W-bit of S5F74 is 1, the Host acknowledges the Alarm.
4.		The Equipment recognizes that the alarm condition has gone "off" (i.e. has become Safe).
5.	H <- E S5F73 [W]	The Equipment reports the Alarm going off. The high-order bit of ALCD is "0".
6.	H -> E S5F74	If the W-bit in S5F74 is 1, the Host acknowledges the Alarm.

5.3.5 Alarm Report (GEM, Ver 1.7 Compatibility)

 **NOTE** This scenario is provided only for compatibility with Host computers which support GEM, Version 1.7.

Table 5-25 SECS Messages Alarm Report (GEM, Ver 1.7 Compatibility)

Step	SECS Message	Description
1.		The equipment constant "ConfigAlarms" is set to 1 for GEM, Version 1.7 compatibility. The Equipment recognizes that an alarm condition has gone "on" (i.e. has become Unsafe).
2.	H <- E S5F71 [W]	The Equipment reports the Alarm going on. The high-order bit of ALCD is "1".
3.	H -> E S5F72	If the W-bit in S5F71 is 1, the Host acknowledges the Alarm.
4.		The Equipment recognizes that the alarm condition has gone "off" (i.e. has become Safe).
5.	H <- E S5F71 [W]	The Equipment reports the Alarm going off. The high-order bit of ALCD is "0".
6.	H -> E S5F72	If the W-bit in S5F71 is 1, the Host acknowledges the Alarm.

5.4 Control State

5.4.1 Host Sends On-Line Command

Assumption: Control State is “Host Off-Line”. Variable GemControlState = 3.

Table 5-26 SECS Messages Host Sends On-Line Command

Step	SECS Message	Description
1.	H -> E S1F17 W	Host instructs the Equipment to go “On-Line”.
2.	H <- E S1F18	Equipment responds to successful On-Line transition with ONLACK=0. Control state transits to either Local or Remote as guided by EC GemOnlineSubstate.
3.	H <- E S6F11 W	The Equipment signals CEID: GemControlState LOCAL or GemControlState REMOTE.
4.	H -> E S6F12	The Host acknowledges the event.

5.4.2 Host Sends Off-Line Command

Assumption: Control State is “On-Line”.

Table 5-27 SECS Messages Host Sends Off-Line Command

Step	SECS Message	Description
1.	H -> E S1F15 W	Host instructs the Equipment to go “Off-Line”.
2.	H <- E S1F16	Equipment Control State transitions to “Host Off-Line” (GemControlState = 3) and responds to primary. OFLACK = 0.

5.4.3 Host Sends Remote Command

Assumption: Control State is on-line and Remote.

Table 5-28 SECS Messages Host Sends Remote Command

Step	SECS Message	Description
1.	H -> E S2F41 [W]	The Host sends the command. The W-bit in this message may be either 0 or 1.
2.	H <- E S2F42	If the W-bit was 1, the Equipment acknowledges the command. If the Equipment cannot perform the command, the acknowledge code in this message is non-zero. If the command can be completed "immediately", the command is performed and the acknowledge code in this message is 0. Otherwise, if the command takes a significant amount of time to complete, the acknowledge code is 4. Successful completion of a command may trigger one or more events.

5.4.4 Equipment Rejects Host Command

Assumption: Control State is Local and On-Line

Table 5-29 SECS Messages Equipment Rejects Host Command

Step	SECS Message	Description
1.	H -> E S2F41 [W]	The Host sends the command. The W-bit in this message may be either 0 or 1.
2.	H <- E S2F42	If the W-bit in S2F41 is 1, the Equipment acknowledges the command. The acknowledge code in this message is 64 (Control State is incorrect). If the W-bit is 0, this message is not sent. In either case, the Equipment does not perform the command.

5.4.5 Go Remote, Operator-Initiated

Table 5-30 SECS Messages Go Remote, Operator-Initiated

Step	SECS Message	Description
1.		ControlState is Local. The Operator switches the Equipment to Remote Control.
2.	H <- E S6F11 W	The Equipment signals CEID GemControlState REMOTE. Event Reports as appropriate.
3.	H -> E S6F12	The Host acknowledges the report.

5.4.6 Go Local, Operator-Initiated

Table 5-31 SECS Messages Go Local, Operator-Initiated

Step	SECS Message	Description
1.		ControlState is Remote. The Operator switches the Equipment to Local control state.
2.	H <- E S6F11 W	The Equipment signals CEID GemControlState LOCAL. Event Reports as appropriate.
3.	H -> E S6F12	The Host acknowledges the report.

5.4.7 Go Local, Host-Initiated

Table 5-32 SECS Messages Go Local, Host-Initiated

Step	SECS Message	Description
1.		ControlState is Remote.
2.	H -> E S2F41 [W]	Remote Command (GO LOCAL). The Host commands the Equipment to go into Local control state.
3.	H <- E S2F42	If the W-bit in S2F41 is 1, the Equipment acknowledges the command. HCACK is zero.
4.	H <- E S6F11 W	The Equipment signals CEID GemControlState LOCAL. Event Reports as appropriate.
5.	H -> E S6F12	The Host acknowledges the report.

5.4.8 Operator Command, Successful

Table 5-33 SECS Messages Operator Command, Successful

Step	SECS Message	Description
1.		ControlState is Local. The Operator issues a front-panel INITIATE PROCESS command. The Equipment performs the command.
2.	H <- E S6F11 W	The Equipment signals CEID LotStart. Event Reports as appropriate.
3.	H -> E S6F12	The Host acknowledges the report.

5.5 Process Program Management

5.5.1 Unformatted, Host-Initiated Download

Table 5-34 SECS Messages Unformatted, Host-Initiated Download

Step	SECS Message	Description
1.	H -> E S7F1 W	Host requests permission to send a multi-block Process Program to the Equipment. If the Process Program is single-block, this step and the next one may be skipped.
2.	H <- E S7F2	The Equipment grants permission for the Host to send the Process Program.
3.	H -> E S7F3 W	Host sends the process Program to the Equipment.
4.	H <- E S7F4	The Equipment acknowledges receipt of the Process Program. The Equipment checks the received Process Program for validity. If the process Program is valid, the Equipment stores the Process Program in its library and sends an acknowledge code of zero in this message. If the Process Program is not valid, or could not be stored in the library, the acknowledge code in this message is non-zero.

5.5.2 Unformatted, Host-Initiated Upload

Table 5-35 SECS Messages Unformatted, Host-Initiated Upload

Step	SECS Message	Description
1.	H -> E S7F5 W	Host requests a Process Program from the Equipment library.
2.	H <- E S7F5	The Equipment sends the Process Program. If the Process Program does not exist, the data portion of this message is an empty list.

5.5.3 Unformatted, Equipment-Initiated Download

Table 5-36 SECS Messages Unformatted, Equipment-Initiated Download

Step	SECS Message	Description
1.	H <- E S7F5 W	Equipment requests a Process Program.
2.	H -> E S7F6	The Host sends the Process Program. If the Process Program is valid, the Equipment stores the Process Program in its library, and the scenario ends. If the data portion of S7F6 is an empty list, or if the Process Program is not valid, the Equipment does not store it in its library and the scenario continues.
3.	H <- E S6F11 W	The Equipment sets "PPCHANGENAME" to the requested PPID and signals CEID GemBadDownloadEvent. Event reports as appropriate.
4.	H -> E S6F12	The Host acknowledges the report.

5.5.4 Unformatted, Equipment-Initiated Upload

Table 5-37 SECS Messages Unformatted, Equipment-Initiated Upload

Step	SECS Message	Description
1.	H <- E S7F1 W	Process Program Inquire. If S7F3 is multi-block, the Equipment requests permission to send a multi-block message. If S7F3 is single-block, skip this and the following step.
2.	H -> E S7F2	Process Program Grant. The Host grants permission. If PPGNT is non-zero, the scenario fails here.
3.	H <- E S7F3 W	Send Process Program. The Equipment uploads Process Program to Host.
4.	H -> E S7F4	The Host acknowledges. The Equipment ignores ACKC7.

5.5.5 Host Deletes Process Program

Table 5-38 SECS Messages Host Deletes Process Program

Step	SECS Message	Description
1.	H -> E S7F17 W	Host sends a request to delete one or more Process Programs from the Equipment's library of Process Programs.
2.	H <- E S7F18	The Equipment replies with an acknowledge code. If all specified Process Program(s) were deleted successfully, the acknowledge code is 0. If one or more of the specified Process Programs could not be deleted, the acknowledge code is non-zero.

5.5.6 Host Requests Directory

Table 5-39 SECS Messages Host Requests Directory

Step	SECS Message	Description
1.	H -> E S7F19 W	Host requests the names (PPIDs) of all Process Programs that are stored in the Equipment's Process Program library.
2.	H <- E S7F20	The Equipment replies with the list of PPIDs.

5.5.7 Operator Changes Process Program Library

Table 5-40 SECS Messages Operator Changes Process Program Library

Step	SECS Message	Description
1.		The Operator creates, changes, or deletes a Process Program in the Library.
2.	H <- E S6F11 W	The Equipment sets PPCHANGESTATUS to "Create", "Change", or "Delete", as appropriate, sets PPCHANGENAME, and signals CEID GemPPChangeEvent. Event Reports as appropriate.
3.	H -> E S6F12	The Host acknowledges the report.

5.6 Equipment Terminal Communications

5.6.1 Host to Equipment, Single Line

Table 5-41 SECS Messages Host to Equipment, Single Line

Step	SECS Message	Description
1.		The Host has data to display at the Equipment's front panel.
2.	H -> E S10F3 [W]	Terminal Display. The Host sends text. The Equipment displays the text on its front panel.
3.	H <- E S10F4	If the W-bit in S10F3 is 1, the Equipment acknowledges.
4.		The Operator acknowledges that he/she has read the message.
5.	H <- E S6F11 W	The Equipment signals CEID S10Ack. Event Reports as appropriate.
6.	H -> E S6F12	The Host acknowledges the report.

5.6.2 Host to Equipment, Multi-Line

Table 5-42 SECS Messages Host to Equipment, Multi-Line

Step	SECS Message	Description
1.		The Host has a multi-line data to display at the Equipment front panel.
2.	H -> E S10F5 [W]	Terminal Display Multiple. The Host sends text. The Equipment displays the text on its front panel.
3.	H <- E S10F6	If W-bit in S10F5 is 1, the Equipment acknowledges.
4.		The Operator acknowledges that he/she has read the message.
5.	H <- E S10F11 W	The Equipment signals CEID HostMsgAck. Event Reports as appropriate.
6.	H -> E S6F12	The Host acknowledges the report.

5.6.3 Equipment Sends Text to Host

Table 5-43 SECS Messages Equipment Sends Text to Host

Step	SECS Message	Description
1.		The Operator enters data to send to the Host.
2.	H <- E S10F1 [W]	Equipment sends text to Host. The W-bit in this message may be either 0 or 1. The Host displays the message for the Operator.
3.	H -> E S10F2	If the W-bit in S10F1 is 1, the Host acknowledges the text message.

5.7 SECS Error Messages

5.7.1 Unrecognized Device ID

Table 5-44 SECS Messages Unrecognized Device ID

Step	SECS Message	Description
1.	H -> E SnFn [W]	Host sends a message with a bad Device ID in the header. The W-bit can be either 0 or 1.
2.	H <- E S9F1	Equipment replies with "Unrecognized Device ID".

5.7.2 Unrecognized Stream

Table 5-45 SECS Messages Unrecognized Stream

Step	SECS Message	Description
1.	H -> E SnFn [W]	Host sends a primary message with a stream number that the Equipment does not support. The W-bit can be either 0 or 1.
2.	H <- E S9F3	Equipment replies with "Unrecognized Stream".

5.7.3 Unrecognized Function

Table 5-46 SECS Messages Unrecognized Function

Step	SECS Message	Description
1.	H -> E SnFn [W]	Host sends a primary message with a stream number for which the Equipment recognizes some messages, but with a function number that the Equipment does not support for that stream. The W-bit can be either 0 or 1.
2.	H <- E S9F5	Equipment replies with "Unrecognized Function".

5.7.4 Illegal Data Format

Table 5-47 SECS Messages Illegal Data Format

Step	SECS Message	Description
1.	H -> E SnFn [W]	Host sends a message with a stream and function that the Equipment recognizes, but with a data format that is incorrect. The W-bit can be either 0 or 1.
2.	H <- E S9F7	

5.7.5 Data Too Long

Table 5-48 SECS Messages Data Too Long

Step	SECS Message	Description
1.	H -> E SnFn [W]	Host sends a message with a stream and function that the Equipment recognizes, but contains more data than expected. The W-bit can be either 0 or 1.
2.	H <- E S9F11	Equipment replies with "Data Too Long". If the erroneous message is a primary with the W-bit set to 1, then in some cases the Equipment will reply with the usual secondary response with an appropriate error code, instead of S9F11. If the erroneous message is a secondary, the Equipment makes no reply at all.

5.8 Clock

5.8.1 Host Sets Date and Time

Table 5-49 SECS Messages Host Sets Date and Time

Step	SECS Message	Description
1.	H -> E S2F31 W	Date and Time Send. The Host sends a new Date and Time to the Equipment.
2.	H <- E S2F32	The Equipment sets its Clock/Calendar hardware and acknowledges the command.

5.8.2 Host Requests Date and Time

Table 5-50 SECS Messages Host Requests Date and Time

Step	SECS Message	Description
1.	H -> E S2F17 W	Date and Time Request. The Host requests Date and Time from the Equipment.
2.	H <- E S2F18	The Equipment sends its Date and Time.

5.8.3 Equipment Requests Date and Time

Table 5-51 SECS Messages Equipment Requests Date and Time

Step	SECS Message	Description
1.	H <- E S2F17 W	Date and Time Request. The Equipment requests Date and Time from the Host.
2.	H -> E S2F18	The Host sends its Date and Time. The Equipment sets its Clock/Calendar hardware according to the contents of this message.

5.9 Spooling

For all of the spooling scenarios, spooling is meaningful only when Control State (CONTROLSTATE = 4 or 5) is “On-Line”. When CONTROLSTATE is “Off-Line” (CONTROLSTATE = 1, 2, or 3), the Equipment sends only stream one primaries and SnF0 secondaries, neither of which are eligible for spooling.

5.9.1 Host Enables Spooling of Messages

Table 5-52 SECS Messages Host Enables Spooling of Messages

Step	SECS Message	Description
1.	H -> E S2F43 W	<p>Host requests that messages be eligible for spooling using the following message:</p> <pre> S2F43 W * H -> E <L <L [2] <U1 STRID> * Msg Stream <L <U1 FCNID> * Msg Fcn ... > ... > . </pre>
2.	H <- E S2F44	<p>The Equipment enables spooling for the messages requested by the Host. Response has RSPACK set to zero as follows:</p> <pre> S2F44 <L [2] <B [1] 00> * RSPACK <L> > . </pre>

5.9.2 Messages Spooled and Transmitted

Assumption: Spool State is “Spool Inactive”.

Table 5-53 SECS Messages Spooled and Transmitted

Step	SECS Message	Description
1.	H <- E SnFn	Equipment attempts to send any message to the Host.
2.		After failure to deliver message, the Equipment assumes that the link is down, and will start to spool all messages marked for spooling. The first message spooled is the collection event “SpoolActivated”.
3.	H <- E S1F13 W	Equipment attempts to establish communications. This message will repeat every “EstablishCommunicationsTimer” seconds until successful.
4.	H -> E S1F14	Communications established. Communications state transits to “Communicating”. If COMMACK is not zero, communications are not established and scenario proceeds at Step 3.
5.	H -> E S6F23 W	Host requests that Equipment begin de-spooling messages. RSDC is zero in this message.
6.	H <- E S6F24	Equipment indicates that it will start to send spooled messages with return code RSDA = 0x00.
7.		Equipment will start to de-spool messages. This process is single-threaded. That is, when Equipment sends a de-spooled message with the W-bit set to “1”, Equipment must be receive the Host reply before the Equipment will send next de-spooled message. If EC “MaxSpoolTransmit” is zero, all messages will be transmitted. If it is set to another number, this number of messages will be sent. The Equipment will await the next S6F23 to send the next messages.
8.	H <- E S6F11 W	The Equipment signals CEID GemSpoolActivated. This was the first message in the spool if it was not over-written.
9.	H -> E S6F12	Host acknowledges the start of the spool transfer.
10.		Equipment will de-spool messages one at a time from oldest to youngest until one of the following criteria is met: <ul style="list-style-type: none"> 1. All messages have been transmitted (go to Step 13); or 2. When “MaxSpoolTransmit” is not zero, and the messages transmitted has reached MaxSpoolTransmit limit (go to Step 11). <p>Some spooled messages (usually multi-block) consist of a SECS conversation of type “Inquire, Grant, Send, Acknowledge”. During de-spool, if the Host rejects the Inquire, the multi-block message is removed from the spool and not transmitted. De-spooling continues.</p>

Table 5-53 SECS Messages Spooled and Transmitted

Step	SECS Message	Description
11.	H -> E S6F23 W	The Host requests that the Equipment continue de-spooling messages.
12.	H <- E S6F24	Equipment indicates that it will start to send spooled messages with return code RSDA = 0x00. Go to Step 10.
13.	H <- E S6F11 W	Equipment notifies the Host that sending of spooled messages has been completed by sending CEID GemSpooling Deactivated.
14.	H -> E S6F12	Host acknowledges that the spool has been cleared and is deactivated.

5.9.3 Host Purges Spool

Assumption: spool state is "Spool Active"

Table 5-54 SECS Messages Host Purges Spool

Step	SECS Message	Description
1.	H -> E S6F23 W	Host sends S2F23, requesting that spool be discarded with RSDC set to one.
2.	H <- E S6F24	Equipment deletes spooled data and returns RSDA code zero.

6 Machine Variable Definitions

The following data variables are collected by the Host to support intelligent communications with the Equipment:

- [Status Variables](#)
- [Data Variables](#)
- [Equipment Constants](#)

Each variable is given a header line with its associated ID value and its name. The storage type and the definition of the variable are listed below in smaller type. Variables listed in the header in capital letters are GEM standards. The others belong to Fluidmove.

All variables are listed in alphabetical order.

6.1 Status Variables

Table 6-1 Status Variables

Variable Name	ID	Storage Type	Description
ABORTLEVEL	21	U1	The abort level of the most recent ABORT command.
ALARMID	22	U4	This variable contains the ID of the last alarm to be reported to the Host.
ALARMSENABLED	23	List	This variable contains the list of the currently enabled alarms. Refer to Appendix A for the format.
ALARMSERIAL	26	U4	The sequence number (count) of the most recent alarm change (going on or going off). This number starts at zero at power-up and increments by one for each following alarm transition.
ALARMSSET	24	List	This variable contains the list of alarms which are currently set.
ALARMSTATE	25	U1	The state of the current alarm. Non zero values indicate the alarm is set.
BoardCount	106	U4	The number of boards processed since the Power On event or since the last Process entry into the Running state.
CameraXFieldMils	700	U2	The size in mils of the X coordinate axis field of view seen by the camera.
CameraYFieldMils	701	U2	The size in mils of the Y coordinate axis field of view seen by the camera.

Table 6-1 Status Variables (continued)

Variable Name	ID	Storage Type	Description
CLOCK	27	A[16]	The current value of the clock accurate to hundredths of a second. The format is: YYYYMMDDHHmmsscc . This format is always the same, regardless of TIMEFORMAT.
CONTROLSTATE	28	U1	The value indicating the current Control State Machine state: 1 - OffLine/Equipment OffLine 2 - OffLine/Attempt OnLine 3 - OffLine/Host OffLine 4 - OnLine/Local 5 - OnLine/Remote
DeviceID	115	A[12]	The SECS Device ID.
EventLogFilename	104	A[12]	The name of the file holding the event log.
EVENTSENABLED	30	List	This is the list of events which are enabled for reporting to the Host.
FluidFileName	300	A[12]	The name of the data file holding the dispensing fluid data. Fluid files have the ".flu" extension.
FluidLotNumber	301	A[20]	The lot number of the dispensing fluid.
FluidThawTime	302	A[14]	The time stamp, in the YYYYMMDDhhmmss format, at which the fluid was removed from the refrigerator and began to warm up.
MachineID	102	A[20]	The model number and serial number of the Asymtek machine. Refer to Appendix A for the format.
MDLN	31	A[6]	The model designation for this machine.
PPDirectory	103	A[30]	The directory path of the Process Programs on the hard disk.
PPEXECNAME	32	A[0..8]	The currently selected Process Program ID number.
PREVIOUSCEID	33	U4	The latest event ID to be sent to the Host.
PREVIOUSCOMMAND	34	A[0..9]	The latest remote command received from the Host.
PREVIOUSCONTROLSTATE	35	U1	The value indicating the previous Control State for the Equipment: 1 - Off-Line / Equipment Off-Line 2 - Off-Line /Attempt On-Line 3 - Off-Line/Host Off-Line 4 - On-Line Local 5 - On-Line Remote

Table 6-1 Status Variables (continued)

Variable Name	ID	Storage Type	Description
PREVIOUSPROCESSSTATE	36	U1	The previous Process State for the Equipment. The values for this state can be found in Appendix A .
PROCESSSTATE	37	U1	The current Process State for the Equipment. The values for this state can be found in Appendix A .
ProductionStartTime	105	A[14]	The time stamp at which the last production run began. Refer to Appendix A for the format.
RunMode	110	U1	The specific type of runtime operation being conducted; dry run, production run, pass-through, or prototype test run.
SOFTREV	38	A[6]	The software revision number in ASCII code.
SoftwareID	101	A[20]	Fluidmove name and version code.
SPOOLCOUNTACTUAL	48	U4	A count of the number of messages actually present on the spool disk, adjusted for any messages which have been overwritten or discarded.
SPOOLCOUNTTOTAL	49	U4	A count of the number of messages the Equipment attempted to write to the spool disk. This number includes messages actually present on the spool disk, and any messages which may have been overwritten or discarded.
SPOOLFULLTIME	50	A[16]	The date and time at which the Spool file became full. The format is : YYYYMMDDhhmmsscc .
SPOOLLOADSUBSTATE	51	U4	The current state within the SPOOL LOAD super-state. 1 - Spool Active 2 - Spool Inactive
SPOOLSTARTTIME	52	A[16]	See CLOCK variable above for this format.
SPOOLSTATE	53	U4	The current Spool State within the POWER ON super-state. 3 - Purge Spool 4 - Transmit Spool 5 - No Spool output
SPOOLUNLOADSUBSTATE	54	U4	The current Spool State within the SPOOLUNLOAD super-state. 6 - Spool not full 7 - Spool full
TIME	39	A[12]	The current time accurate to the second. The format is YYMMDDhhmmss . This format is always the same, regardless of TIMEFORMAT.

6.2 Data Variables

Table 6-2 Data Variables

Variable Name	ID	Storage Type	Description
ALARMTEXT	1000	A[0..40]	The Alarm Text (ALTX) for the most recent alarm transition.
ALARMSEVERITYCODE	1001	B[1]	The Severity Code (the low order seven bits) of the most recent alarm transition.
BarcodeRaw	350	A[30]	The barcode string exactly as it is read by the scanner from the barcode tag on the board at the dispense station.
BarcodeFiltered	351	A[30]	The barcode string read in from the scanner after unwanted characters are filtered out as specified by the Operator.
BoardCycleTime	114	U2	The number of seconds required to complete dispensing an entire board of substrates.
ConveyorSpeed1	500	F4	The Conveyor 1 belt speed during board transfer between dispensing positions. The units are in./sec.
ConveyorSpeed2	501	F4	The Conveyor 2 belt speed during board transfer between dispensing positions. The units are in./sec.
DWVRESULT	408	U2	Result of Dispense Weight Verification Routine: 0 = Pass 1 = Fail: Setup error (scale not ready, limits out of range, etc.) 2 = Fail: Out of Range 3 = Fail: Weight measured below min deviation 4 = Fail: Weight measured above max deviation 5 = Fail: User abort 6 = Fail: Other reason than listed above
DWVVALVE	409	U2	Valve used during Dispense Weight Verification: 1 = Valve 1 2 = Valve 2 3 = Valve 3 Valid only after collection event "DispenseWeightComplete" occurs.
DWVTARGET	410	F8	Dispense Weight Verification target weight. Valid only after collection event "DispenseWeightComplete" occurs.

Table 6-2 Data Variables (continued)

Variable Name	ID	Storage Type	Description
DWVDISPENSES	411	U4	<p>Dispense Weight Verification: number of dispenses that will be performed.</p> <p>Valid only after collection event "DispenseWeightComplete" occurs.</p>
DWVTARGETRANGE	412	F8	<p>Dispense Weight Verification Target Range: If range limit checking is enabled, this variable will contain the maximum allowable range for the dispense weight verification routine. If limit checking is not enabled, this variable will contain "-1".</p> <p>Valid only after collection event "DispenseWeightComplete" occurs.</p>
DWVTARGETMINLIMIT	413	F8	<p>Minimum allowable deviation from the target weight of the dispense weight for the Dispense Weight Verification routine.</p> <p>Note that if the verification routine fails and the failed weight is required, the data variable "SCALEMEASUREMENT1" (if Valve 1) or "SCALEMEASUREMENT2" (if Valve 2) will have the last value read from the scale.</p> <p>Valid only after collection event "DispenseWeightComplete" occurs.</p>
DWVTARGETMAXLIMIT	414	F8	<p>Maximum allowable deviation from the target weight of the dispense weight for the Dispense Weight Verification routine.</p> <p>Note that if the verification routine fails and the failed weight is required, the data variable "SCALEMEASUREMENT1" (if Valve 1) or "SCALEMEASUREMENT2" (if Valve 2) will have the last value read from the scale.</p> <p>Valid only after collection event "DispenseWeightComplete" occurs.</p>
DWVMEASUREDRANGE	415	F8	<p>Dispense Weight Verification Measured Range: If range limit checking is enabled, this variable will be compared against DMVTARGETRANGE and used as one of the conditions for a pass/fail result. If limit checking is not enabled, this value will still be valid but not used in the pass/fail decision.</p> <p>If the routine fails to due limit checking or is interrupted before it completes, the variable will contain "-1".</p> <p>Valid only after collection event "DispenseWeightComplete" occurs.</p>

Table 6-2 Data Variables (continued)

Variable Name	ID	Storage Type	Description
DWVMEASUREDAVG	416	F8	Dispense Weight Verification Average: average weight of all dispenses after the dispense weight verification completes or "-1" if the routine fails or is interrupted before it completes. Valid only after collection event "DispenseWeightComplete" occurs.
ECIDCHANGE	46	U4	The ID of the last event to be reported to the Host.
FluidState1	306	A[10]	Fluid level of syringe on Valve 1 as reported by the low fluid sensor or fluid level monitoring software. This value is updated twice per board. Once when the board is loaded and ready for dispensing and again when dispensing is complete on that board. Possible values are: "FULL" – Fluid level is full. "LOW" – Fluid level has reached the low level. "EMPTY" – Fluid level is close to empty. This value is possible only with the two position hardware sensor. "NONE" – Fluid sensing sensors do not exist or software monitoring has not been turned on. "ERROR" – Error when using the two position hardware sensor. Signals indicate empty but not low.
FluidState2	307	A[10]	Same as FluidState1, but for Valve 2.
FlowRate1	400	F8	The most current fluid flow rate in mg. per second for Valve 1.
FlowRate2	403	F8	The most current fluid flow rate in mg. per second for Valve 2.
FlowRateMax1	402	F8	The maximum flow rate in mg./sec. allowed during this run for Valve 1.
FlowRateMax2	405	F8	The maximum flow rate in mg./sec. allowed during this run for Valve 2.
FlowRateMin1	401	F8	The minimum flow rate in mg./sec. allowed during this run for Valve 1.
FlowRateMin2	404	F8	The minimum flow rate in mg./sec. allowed during this run for Valve 2.
GEMLIMITSVID	57	U4	Contains the VID of the variable whose value crossed defined limits.

Table 6-2 Data Variables (continued)

Variable Name	ID	Storage Type	Description
NumFailedBoards	107	U4	The number of boards failed since PwrUp or since the Process State entered the Running state.
PPCHANGENAME	40	A[0..8]	The PPID of the Process Program most recently changed.
PPCHANGESTATUS	41	U1	The last action performed on the Process Program. 1 - Created 2 - Changed 3 - Deleted
ScaleMeasurement1	406	F8	The actual value read from the scale during a Flow Rate Verification Procedure when Valve 1 is being used.
ScaleMeasurement2	407	F8	The actual value read from the scale during a Flow Rate Verification Procedure when Valve 2 is being used.
TEMPHTR1CHAN1 – TEMPHTR1CHAN17	801 to 817	F8	Heater 1 temperatures for channels 1-17 respectively (DV 801 = channel 1, DV 802 = channel 2, etc.). The units are in degrees. No other information is supplied such as the unit of degrees (Centigrade or Fahrenheit) or what device the channel is mapped to (ie, pre-dispense station, needle heater, etc.). A value of negative one (-1) indicates the channel is not monitored or not turned on. Note: These variables are only updated between boats and only when monitored by “Verify Temperature Before Initial Dispense”.
TEMPHTR2CHAN1 – TEMPHTR2CHAN17	818 to 834	F8	Identical to Data Variables 801-817 except that they refer to Heater 2 channels 1-17, respectively (DV 818 = channel 1 of heater 2, DV 819 = channel 2 of heater 2 etc.)
TEMPHTR3CHAN1 – TEMPHTR3CHAN17	835 to 851	F8	Identical to Data Variables 801-817 except that they refer to Heater 3 channels 1-17, respectively (DV 835 = channel 1 of heater 3, DV 836 = channel 2 of heater 3 etc.)

6.3 Equipment Constants

Table 6-3 Equipment Constants

Variable Name	ID	Storage Type	Description
BOARDFREQUENCY	610	U4	This value is set by the station controller to the board frequency it requires collection event 2010 to occur. The default is zero which prevents collection event 2010 from triggering.
CONFIGALARMS	1	U1	This EC determines the type of alarm message which is sent following an alarm. 0 – S5F1, 1 – S5F71, 2 – S5F73.
CONFIGCONNECT	2	U1	The EC which determines which message type the Equipment uses for Connection Request. 0 – S1F1, 1 – S1F65, 2 – S1F13
CONFIGEVENTS	3	U1	The EC which determines the choice of Event Report message. 0 – S6F9 or S6F3, 1 – S6F11, or S6F13.
CONFIGSPOOL	63	U4	This variable defines the current Spooling State: 0 - Disabled 1 - Enabled
DEVICENAME	29	A[20]	This is the name chosen by the Host in its references to the machine.
ESTABLISHCOMMUNICATIONSTIMER	6	U2	The delay in seconds between each attempt to reestablish communications.
GEMLIMITSDELAY	60	U2	Determines how often the Equipment checks if variables are within the defined limits (seconds).
INITCOMMSTATE	8	U1	Indicates weather Host communications should be enabled in the initial Communications State entered following Power Up. The two assignable values are: 1 - Enable Host Communications 2 - Disable
INITCONTROLSTATE	9	U1	The initial Control State to be entered following Power Up. The two values are: 1 - Off-Line 2 - On-Line
HEARTBEAT	10	U2	The time in seconds between each S1F1 “Are You There” message sent to the Host. These messages are sent to confirm that the communications link between the Host and the Equipment is still valid during light message traffic.

Table 6-3 Equipment Constants (continued)

Variable Name	ID	Storage Type	Description
MAXSPOOLTRANSMIT	46	U4	This is the largest number of messages that may be read from the Spool file during a single read. This limits the number of messages sent to the Host in response to the S6F23 message and helps to prevent clogging of the communications link during a link recovery after a long communications failure.
MeasFlowEnabled	601	BOOL	This Boolean flag indicates whether periodic flow rate calibration operations are enabled. 1 - Enabled 0 - Disabled
OFFLINESUBSTATE	42	U1	This variable determines the Control State that the Equipment enters when it enters the OffLine super-state. The allowable values are: 1 - Equipment Off-Line 2 - Attempt On-Line 3 - Host Off-Line
ONLINEFAILED	43	U1	This variable controls the entry state resulting from a failed attempt to go On-Line. The two values are: 1 - Equipment Off-Line 3 - Host Off-Line
ONLINESUBSTATE	44	U1	This variable controls the entry state resulting from a successful attempt to go On-Line. The two values are: 4 - On-Line - Local 5 - On-Line - Remote
OVERWRITESPOOL	62	BOOL	This variable enables overwriting the Spool when it becomes full.
PurgeEnabled	600	BOOL	The state of periodic purging operations. 1 - Enabled 0 - Disabled
RPTYPE	17	BOOL	This variable enables the Equipment to send annotated reports to the Host on request.
TEMPERATUREDVUPDATE	611	BOOL	Set by the station controller to turn heater temperature data variable updating on (TRUE) or off (FALSE). The default value is TRUE.
VisionFailures	112	U4	The number of vision system failures counted by the Fluidmove software since the Power On event or latest Process Program change. The Host may clear this variable to measure failures during a run.

Table 6-3 Equipment Constants (continued)

Variable Name	ID	Storage Type	Description
WBITS10	18	U1	This variable determines the default state of the W bit for all messages in stream 10 sent from the Equipment to the Host.
WBITS5	19	U1	This variable determines the default state of the W bit for all messages in stream 5 sent from the Equipment to the Host.
WBITS6	20	U1	This variable determines the default state of the W bit for all messages in stream 6 sent from the Equipment to the Host.

7 Host-to-Equipment Messages

 **NOTE** In Table 7-1 “Primary” and “Reply” columns:

* = Fluidmove secondary message handlers

** = Fluidmove primary message handlers

Table 7-1 Host-to-Equipment Messages

Primary	Reply	Cstate	Description	Notes
S1F1	S1F2	4,5	Are You There	None
S1F3	S1F4	4,5	Selected Status	Possible variable access
S1F11	S1F12	4,5	Status Variable Namelist Request	None
S1F13	S1F14	All	Connect Request	None
S1F15	S1F16*	4,5	Request Off-Line	None
S1F17	S1F18*	1,2,3	Request On-Line	None
S1F65	S1F66*	All	Connect Request	None N
S2F13	S2F14	4,5	Equipment Constant Request	Possible variable access (only if non-ECs requested).
S2F15	S2F16*	4,5	New Equipment Constant Send	Possible EC validation routines. EC-Changed processing routine. Disk write occurs.
S2F17	S2F18*	4,5	Date and Time Request	None
S2F21	S2F22	5	Remote Command	Primary message handler N (for Non GEM Hosts).
S2F23	S2F24	4,5	Trace Initialize	None
S2F25	S2F26	4,5	Loopback Diagnostic	None E
S2F27	S2F28*	5	Initiate Processing Request	Primary Message Handler N
S2F29**	S2F30	4,5	Equipment Constant Namelist Request	None E

Table 7-1 Host-to-Equipment Messages (continued)

Primary	Reply	Cstate	Description	Notes
S2F31	S2F32	4,5	Date and Time Send	None
S2F33	S2F34	4,5	Define Report	None Disk write occurs.
S2F35	S2F36	4,5	Link Event Report	None Disk write occurs.
S2F37	S2F38	4,5	Enable/Disable Event Report	None. Disk write occurs.
S2F39	S2F40	4,5	Multi-Block Inquire/Grant	None
S2F41**	S2F42*	5	Remote Command with Parameters	Primary Message Handler
S2F43	S2F44	4,5	Reset Spooling Streams and Functions	None
S2F45	S2F46	4,5	Define Variable Limits Attributes	None
S2F47	S2F48	4,5	Variable Limit Attribute Request	None
S5F3	S5F4	4,5	Enable/Disable Alarm	None Disk write occurs.
S5F5**	S5F6*	4,5	List Alarms	None
S5F7	S5F8*	4,5	List Enabled Alarms	None E
S6F15	S6F16	4,5	Request Event Report	Possible variable access routines.
S6F17	S6F18	4,5	Request Annotated Event Report	Possible variable access routines. E
S6F19	S6F20	4,5	Request Report	Possible variable access routines.
S6F21	S6F22	4,5	Request Annotated Report	Possible variable access routines. E
S6F23	S6F24	4,5	Request Spooled Data	None
S7F1	S7F2	4,5	Process Program Inquire/Grant	None

Table 7-1 Host-to-Equipment Messages (continued)

Primary	Reply	Cstate	Description	Notes
S7F3	S7F4	4,5	Unformatted Process Program Send	UFPP verify Disk write occurs.
S7F5**	S7F6*	4,5	Unformatted Process Program Request	None Disk read occurs.
S7F17**	S7F18	4,5	Process Program Delete	None Disk write occurs.
S7F19	S7F20*	4,5	Process Program Directory	None Disk read occurs.
S10F3**	S10F4	4,5	Terminal Display, Single	Terminal display
S10F5**	S10F6	4,5	Terminal Display, Multiple	Terminal display
S10F9**	S10F10	4,5	Broadcast	Terminal display E

8 Equipment-to-Host Messages

 **NOTE** In Table 8-1 “Reply” column:

* = Fluidmove secondary message handlers

Table 8-1 Equipment-to-Host Messages

Primary	Reply	Description	Notes
-- (any)	SnF0	Primary rejected while Off-Line	None
S1F1	S1F2	Are You There	None (heartbeat) GemGoAOnline (Attempt Online)
S1F13	S1F14	Connect Request	None
S1F65	S1F66	Connect Request	None N
S2F17	S2F18	Date and Time Request	GemHostTimeReq
S5F1	S5F2*	Alarm Report	GemNoteAlarmEvent N
S5F71	S5F72	Alarm Report Block Send	GemNoteAlarmEvent
S5F73	S7F74	Alarm Notification Send	GemNoteAlarmEvent
S6F1	S6F2	Trace Data Send	Possible variable access routines.
S6F3	S6F4	Annotated Event Report Send	GemNoteEvent Possible variable access routines. N
S6F5	S6F6	Multi-Block Data Send Inquire/Grant	None
S6F9	S6F10	Event Report Send	GemNoteEvent Possible variable access routines. N
S6F11	S6F12	Event Report Send	GemNoteEvent Possible variable access routines.

Table 8-1 Equipment-to-Host Messages (continued)

Primary	Reply	Description	Notes
S6F13	S6F14	Annotated Event Report Send	GemNoteEvent Possible variable access routines. N
S7F1	S7F2	Process Program Inquire/Grant	GemUFPPSend or GEMFPPSend
S7F3	S7F4*	Unformatted Process Program Send	GemUFPPSend Disk Read occurs
S7F5	S7F6	Unformatted Process Program Request	GemUFPPLoad UFPPVerify Disk write occurs.
S9F1	--	Error, Device ID	None
S9F3	--	Error, Stream	None
S9F5	--	Error, Function	None
S9F7	--	Error, Data	None
S9F9	--	Error, Transaction Timeout	None
S9F11	--	Error, Data Too Long	None
S9F13	--	Error, Conversation timeout	Sent by application only if required.
S10F1	S10F2	Terminal Request	GemTerminalRequest
S13F1	S13F2	Send Data Set Send	GemDSNameSend

Appendix A – Data Dictionary Variables

Table A-1 is a summary explanation of the machine variables described in [Section 6](#) sorted by ID number and containing details of the content of each variable.

The data formats are as follows:

- A[nn]** ASCII text of length nn. Where two numbers are indicated, they specify a range of acceptable lengths.
- Bool** A boolean flag indicating TRUE or FALSE.
- F4,F8** A floating point number in four bytes.
- I1,I2,I4,I8** Signed integers of the indicated length in bytes.
- U1,U2,U4,U8** Unsigned integers of the indicated length in bytes.
- List** An array of similar structures or primitive elements, as above. The list format is specified in the description field.

Table A-1 Data Dictionary Variables

VID	Class	Format	Name and Description
1	EC	U1	<u>CONFIGALARMS</u> . An EC which controls which Alarm Report message this Equipment will send. 0 = S5F1 default 1 = S5F71 2 = S5F73
2	EC	U1	<u>CONFIGCONNECT</u> . An EC which controls which SECS message this Equipment will use for Connect Request. 0 = S1F1 1 = S1F65 2 = S1F13 default
3	EC	U1	<u>CONFIGEVENTS</u> . An EC which controls some aspects of the Event Reports sent by this Equipment. 0 = S6F9 or S6F3 1 = S6F11 or S6F13 default
5	EC	A[0..22]	<u>DEVICENAME</u> . The Host can change this EC to define a meaningful name for the equipment.
6	EC	U2	<u>ESTABLISHCOMMUNICATIONSTIMER</u> . Time in seconds of how long the equipment will delay after an unsuccessful Connect Request before sending another. Valid values are 0-32000.
8	EC	U1	<u>INITCOMMSTATE</u> . Initial (power-up) Communications State. 0 = Disabled 1 = Enabled

Table A-1 Data Dictionary Variables (continued)

VID	Class	Format	Name and Description
9	EC	U1	<u>INITCONTROLSTATE</u> . Initial (power-up) control super-state. 1 = Off-Line 2 = On-Line
10	EC	U2	<u>HEARTBEAT</u> . The time in seconds that the Equipment will delay before sending S1F1 to test the link. Units are seconds. Valid values are 0-3200 (a setting of zero will disable the heartbeat).
17	EC	BOOL	<u>RPTYPE</u> . This EC controls some aspects of the format of Event Reports sent by this Equipment. FALSE = Normal Event Reports TRUE = Annotated Event Reports
18	EC	U1	<u>WBITS10</u> . An EC which controls the W-Bit setting used when sending S10F1. 0 = W-Bit not set 1 = W-Bit set
19	EC	U1	<u>WBITS5</u> . An EC which controls the W-Bit setting used when sending Alarm Reports (S5F1, S5F71, or S5F73). 0 = W-Bit not set 1 = W-Bit set
20	EC	U1	<u>WBITS6</u> . An EC which controls the W-Bit setting used when sending stream six messages (events, trace) 0 = W-Bit not set 1 = W-Bit set
21	SV	U1	<u>ABORTLEVEL</u> . The AbortLevel of the most recent ABORT command.
22	SV	U4	<u>ALARMID</u> . The ALID of the most recent Alarm transition.
23	SV	List	<u>ALARMSENABLED</u> . A list of all Alarms which are currently enabled. Format as follows: <L,n 1.<U4 ALID> ... n.<U4 ALID> >
24	SV	List	<u>ALARMSSET</u> . A list of all Alarms which are currently in the SET (on) state. Format as follows: <L 1.<U4 ALID> ... n.<U4 ALID> >
25	SV	U1	<u>ALARMSTATE</u> . The Alarm State now in effect for the most recently transitioned alarm. 0 = Alarm transitioned OFF 1 = Alarm transitioned ON

Table A-1 Data Dictionary Variables (continued)

VID	Class	Format	Name and Description
26	SV	U4	<u>ALARMSERIAL</u> . The sequence number of the most recent alarm change (going on or going off). This number starts at zero at power-up and increments by one for each alarm transition which occurs.
27	SV	A[16]	<u>CLOCK</u> . The Equipment's current Date and Time in the following format: YYYYMMDDhhmmsscc. YYYY = year from 0000 to 9999 MM = month from 01 to 12 DD = day from 01 to 31 hh = hours from 00 to 59 mm = minutes from 00 to 59 ss = seconds from 00 to 59 cc = centiseconds from 00 to 99
28	SV	U4	<u>CONTROLSTATE</u> . The current Control State. 1 = Off-Line/Equipment Off-Line 2 = Off-Line/Attempt On-Line 3 = Off-Line/Host Off-Line 4 = On-Line/Local 5 = On-Line/Remote
30	SV	List	<u>EVENTSENABLED</u> . A list of all Events which are currently enabled. Format as follows: <L,n 1.<U4 CEID> ... n.<U4 CEID> >
31	SV	A[6]	<u>MDLN</u> . Model number. The format is a one to six letter, left-justified acronym with blank fill on the right.
32	SV	A[0..12]	<u>PPEXECNAME</u> . The PPID of the currently selected Process Program. This PPID is the DOS 8.3 file name of the recipe. It includes the extension RCP.
33	SV	U4	<u>PREVIOUSCEID</u> . The CEID of the most recent Collection event which has occurred.
34	SV	A[0..9]	<u>PREVIOUSCOMMAND</u> . The name of the most recent command.
35	SV	U1	<u>PREVIOUSCONTROLSTATE</u> . The Control State in effect before the most recent transition to the current Control State. 1 = Off-Line/Equipment Off-Line 2 = Off-Line/Attempt On-Line 3 = Off-Line/Host Off-Line 4 = On-Line/Local 5 = On-Line/Remote

Table A-1 Data Dictionary Variables (continued)

VID	Class	Format	Name and Description
36	SV	U1	<p><u>PREVIOUSPROCESSSTATE</u>. The Process State in effect before the most recent transition to the current Process State.</p> <p>0 = Idle (Boot-up) 1 = Idle 2 = Running 3 = Paused 4 = Aborting 5 = Error</p>
37	SV	U1	<p><u>PROCESSSTATE</u>. The current Process State.</p> <p>0 = Idle (Boot-up) 1 = Idle 2 = Running 3 = Paused 4 = Aborting 5 = Error</p>
38	SV	A[6]	<p><u>SOFTREV</u>. Software revision number with Major and minor parts. Example: "1.02 " The revision is in <u>Major</u> and <u>minor</u> format with a period separating the parts.</p>
39	SV	A[12]	<p><u>TIME</u>. The Equipment's current date and time in the following format: YYMMDDHHMMSS.</p> <p>YYYY = year from 0000 to 9999 MM = month from 01 to 12 DD = day from 01 to 31 hh = hours from 00 to 59 mm = minutes from 00 to 59 ss = seconds from 00 to 59</p>
40	DV	A[0..12]	<p><u>PPCHANGENAME</u>. PPID of the Process Program most recently created, changed, or deleted. This variable is the DOS 8.3 file name of the recipe changed. It includes the extension RCP.</p>
41	DV	U1	<p><u>PPCHANGESTATUS</u>. The action (create, change, delete) taken on a Process Program</p> <p>1 = Created 2 = Changed 3 = Deleted</p>
42	EC	U1	<p><u>OFFLINESUBSTATE</u>. The default (power-up) offline substate of the Control State Model.</p> <p>1 = Equipment Off-Line 2 = Attempt On-Line 3 = Host Off-Line</p>

Table A-1 Data Dictionary Variables (continued)

VID	Class	Format	Name and Description
43	EC	U1	<u>ONLINEFAILED</u> . The default Control State transition when Attempt On-Line fails. 1 = Equipment Off-Line 2 = Host Off-Line
44	EC	U1	<u>ONLINESUBSTATE</u> . The default (power-up) online substate of the Control State Model. 4 = Local 5 = Remote
46	EC	U4	<u>MAXSPOOLTRANSMIT</u> . The maximum number of spooled messages the equipment will send each time the Host reads the spool. A setting of zero indicates that all spooled messages should be sent. Refer to the description of S6F23 in the "SECS Message Detail" section for further information.
48	SV	U4	<u>SPOOLCOUNTACTUAL</u> . A count of the number of messages actually present on the spool disk, adjusted for any messages which have been overwritten or otherwise discarded.
49	SV	U4	<u>SPOOLCOUNTTOTAL</u> . A count of the number of messages the equipment attempted to write to the spool disk. This number includes messages actually present on the spool disk, and also any messages which may have been overwritten or otherwise discarded.
50	SV	A[16]	<u>SPOOLFULLTIME</u> . The date and time at which the spool file became full. Format is: YYYYMMDDhhmmsscc. See description of CLOCK variable (VID 27) above for format details.
51	SV	U4	<u>SPOOLLOADSUBSTATE</u> . The current state within the SPOOL LOAD super-state. 6 = Spool Not Full 7 = Spool Full
52	SV	A[16]	<u>SPOOLSTARTTIME</u> . The date and time at which the first message was written to the current spool file. Format is: YYYYMMDDhhmmsscc. See description of CLOCK variable (VID 27) above for format details.
53	SV	U4	<u>SPOOLSTATE</u> . The current spool state within the POWER ON super-state. 1 = Spool Active 2 = Spool Inactive
54	SV	U4	<u>SPOOLUNLOADSUBSTATE</u> . The current spool state within the SPOOL UNLOAD super-state. 3 = Purge Spool 4 = Transmit Spool 5 = No Spool Output

Table A-1 Data Dictionary Variables (continued)

VID	Class	Format	Name and Description
57	DV	U4	<u>GEMLIMITSVID</u> . Contains the VID of the variable whose value crossed defined limits.
60	EC	U2	<u>GEMLIMITSDELAY</u> . Determines how often the Equipment checks if variables are within the defined limits (seconds).
61	EC	BOOL	Internal to the Equipment. The Host should not access this variable.
62	EC	BOOL	<u>OVERWRITESPOOL</u> . This EC determines the action to be taken by the Equipment when the Spool file reaches its capacity. TRUE = Overwrite Spool FALSE = Do Not Overwrite Spool
63	EC	U4	<u>CONFIGSPOOL</u> . This EC determines whether spooling is enabled or disabled for this Equipment. 0 = Disabled 1 = Enabled
67	DV	U4	<u>ECIDCHANGE</u> . The VID of the Equipment Constant most recently changed by the Operator.
71	EC	U1	<u>TIMEFORMAT</u> . Determines whether STIME is sent in 12-byte or 16-byte format. 0 = 12-byte data format 1 = 16-byte data format
101	SV	A[20]	<u>SoftwareID</u> . The Fluidmove software name and version code. The version is in Major and minor format with a period separating the parts. Up to seven letters in an alphanumeric suffix follow the capitol A and hyphen in the name as shown. Spaces pack any remaining space to the right of the software ID.
102	SV	A[30]	<u>MachineID</u> . The machines Model number and Serial number. The MachineID format is: "Model SNXXXXX ". The Model field is fixed at twenty characters. The Serial Number field is fixed at ten characters and contains up to five characters in the serial number. Spaces pack any remaining space to the right of both fields.
103	SV	A[30]	<u>PPDirectory</u> . The directory path holding the Process Programs. The format is: "vol:\dir1[\dir2[\dir3]]". Brackets indicate optional directory levels. The volume indicator is a single letter.
104	SV	A[12]	<u>EventLogFilename</u> . The name of the file holding the event records log. The DOS 8.3 file name format is used. There are up to eight characters reserved for the name and up to three characters for the extension. The name and extension are thus separated by a period: "name.ext". The file name is left justified within the character string and spaces pack any remaining space to the right of the file name.

Table A-1 Data Dictionary Variables (continued)

VID	Class	Format	Name and Description
105	SV	A[14]	<u>ProductionStartTime</u> . The time stamp when production started. The format is: YYYYMMDDhhmmss . Similar to the TIME(39) variable format. YYYY = year from 0000 to 9999 MM = month from 01 to 12 DD = day from 01 to 31 hh = hours from 00 to 59 mm = minutes from 00 to 59 ss = seconds from 00 to 59
106	SV	U4	<u>BoardCount</u> . The number of boards processed since the Power On event or since the last Process entry into the Running state.
107	DV	U4	<u>NumFailedBoards</u> . The number of boards failed during this run.
110	SV	U1	<u>RunMode</u> . The various types of run operations: 0 = Standby 1 = Production Dry 2 = Production Wet 3 = Pass-through 4 = Manual Wet 5 = Manual Dry 6 = Not Ready 7 = Invalid
112	EC	U4	<u>VisionFailures</u> . The count of vision system failures counted by the Fluidmove software since the Power On event or since the last change of Process Programs. The Host may clear this variable to measure failures during a run.
114	DV	U2	<u>BoardCycleTime</u> . The time in seconds needed to complete dispensing a board.
115	SV	A[12]	<u>Device ID</u> . The SECS Device ID.
300	SV	A[12]	<u>FluidFileName1</u> . This is the name of the file containing the dispensing fluid data for Valve1. The file extension is ".flu". The DOS 8.3 file name format is used. There are up to eight characters reserved for the name and up to three characters for the extension. The name and extension are thus separated by a period: "name.ext". The file name is left justified within the character string, and spaces pack any remaining space to the right of the file name.
301	SV	A[20]	<u>FluidLotNumber1</u> . This is the dispensing fluid lot number recorded by the Operator when the syringe was reloaded. The format is a twenty character ASCII alphanumeric string containing the lot number from the fluid syringe. The number is left justified and blanks fill the remaining space.

Table A-1 Data Dictionary Variables (continued)

VID	Class	Format	Name and Description
302	SV	A[14]	<p><u>FluidThawTime1</u>. This is the time stamp in the YYYYMMDDhhmmss format, at which the fluid was removed from the refrigerator and began to warm up. Similar to the TIME(39) variable format.</p> <p>YYYY = year from 0000 to 9999</p> <p>MM = month from 01 to 12</p> <p>DD = day from 01 to 31</p> <p>hh = hours from 00 to 59</p> <p>mm = minutes from 00 to 59</p> <p>ss = seconds from 00 to 59</p>
303	SV	A[12]	<p><u>FluidFileName2</u>. This is the name of the file containing the dispensing fluid data for Valve 2. See FluidFileName1 (VID 300) for a detailed description.</p>
304	SV	A[20]	<p><u>FluidLotNumber2</u>. This is the dispensing fluid lot number for Valve 2. See FluidLotNumber1 (VID 301) for a detailed description.</p>
305	SV	A[14]	<p><u>FluidThawTime2</u>. This is the time stamp for the fluid for Valve 2. See FluidThawTime1 (VID 302) for a detailed description.</p>
306	DV	A[10]	<p><u>FluidState1</u>. Fluid level of syringe on Valve 1 as reported by the low fluid sensor or fluid level monitoring software. This value is updated twice per board. Once when the board is loaded and ready for dispensing and again when dispensing is complete on that board. Possible values are:</p> <p>“FULL” – Fluid level is full.</p> <p>“LOW” – Fluid level has reached the low level.</p> <p>“EMPTY” – Fluid level is close to empty. This value is possible only with the two position hardware sensor.</p> <p>“NONE” – Fluid sensing sensors do not exist or software monitoring has not been turned on.</p> <p>“ERROR” – Error when using the two position hardware sensor. Signals indicate empty but not low.</p>
307	DV	A[10]	<p><u>FluidState2</u>. Same as FluidState1 but for Valve 2.</p>
350	DV	A[30]	<p><u>BarcodeRaw</u>. The barcode string exactly as it is read by the scanner from the barcode tag on the board at the dispense station.</p>
351	DV	A[30]	<p><u>BarcodeFiltered</u>. The barcode string read in from the scanner after unwanted characters are filtered out as specified by the Operator.</p>
400	DV	F8	<p><u>FlowRate1</u>. The most current fluid flow rate for Valve 1 in mg./sec.</p>
401	DV	F8	<p><u>FlowRateMin1</u>. The minimum flow rate for Valve 1 in mg./sec. allowed during this run.</p>
402	DV	F8	<p><u>FlowRateMax1</u>. The maximum flow rate for Valve 1 in mg./sec. allowed during this run.</p>
403	DV	F8	<p><u>FlowRate2</u>. The most current fluid flow rate for Valve 2 in mg/sec.</p>

Table A-1 Data Dictionary Variables (continued)

VID	Class	Format	Name and Description
404	DV	F8	<u>FlowRateMin2</u> . The minimum flow rate for Valve 2 in mg./sec. allowed during this run.
405	DV	F8	<u>FlowRateMax2</u> . The maximum flow rate for Valve 2 in mg./sec. allowed during this run.
406	DV	F8	<u>ScaleMeasurement1</u> . The actual value read from the scale during a Dispense Weight Verification Procedure when Valve 1 is being used.
407	DV	F8	<u>ScaleMeasurement2</u> . The actual value read from the scale during a Dispense Weight Verification Procedure when Valve 2 is being used.
408	DV	U2	<u>DWVRESULT</u> . Result of Dispense Weight Verification Routine: 0 = Pass 1 = Fail: Setup error (scale not ready, limits out of range, etc.) 2 = Fail: Out of Range 3 = Fail: Weight measured below min deviation 4 = Fail: Weight measured above max deviation 5 = Fail: User abort 6 = Fail: Other reason than listed above
409	DV	U2	<u>DWVVALVE</u> . Valve used during Dispense Weight Verification: 1 = Valve 1 2 = Valve 2 3 = Valve 3 Valid only after collection event "DispenseWeightComplete" occurs.
410	DV	F8	<u>DWVTARGET</u> . Dispense Weight Verification target weight. Valid only after collection event "DispenseWeightComplete" occurs.
411	DV	U4	<u>DWVDISPENSES</u> . Dispense Weight Verification: number of dispenses that will be performed. Valid only after collection event "DispenseWeightComplete" occurs.
412	DV	F8	<u>DWVTARGETRANGE</u> . Dispense Weight Verification Target Range: If range limit checking is enabled, this variable will contain the maximum allowable range for the dispense weight verification routine. If limit checking is not enabled, this variable will contain "-1". Valid only after collection event "DispenseWeightComplete" occurs.
413	DV	F8	<u>DWVTARGETMINLIMIT</u> . Minimum allowable deviation from the target weight of the dispense weight for the Dispense Weight Verification routine. Note: If the verification routine fails and the failed weight is required, the data variable "SCALEMEASUREMENT1" (if valve 1) or "SCALEMEASUREMENT2" (if valve 2) will have the last value read from the scale. Valid only after collection event "DispenseWeightComplete" occurs.

Table A-1 Data Dictionary Variables (continued)

VID	Class	Format	Name and Description
414	DV	F8	<p><u>DWVTARGETMAXLIMIT</u>. Maximum allowable deviation from the target weight of the dispense weight for the Dispense Weight Verification routine.</p> <p>Note: If the verification routine fails and the failed weight is required, the data variable “SCALEMEASUREMENT1” (if valve 1) or “SCALEMEASUREMENT2” (if valve 2) will have the last value read from the scale.</p> <p>Valid only after collection event “DispenseWeightComplete” occurs.</p>
415	DV	F8	<p><u>DWVMEASUREDRANGE</u>. This is the dispense weight verification measured range. If range limit checking is enabled, this variable will be compared against DMVTARGETRANGE and used as one of the conditions for a pass/fail result. If limit checking is not enabled, this value will still be valid but not used in the pass/fail decision.</p> <p>If the routine fails to due limit checking or is interrupted before it completes, the variable will contain “-1”.</p> <p>Valid only after collection event “DispenseWeightComplete” occurs.</p>
416	DV	F8	<p><u>DWVMEASUREDAVG</u>. Dispense Weight Verification Average: average weight of all dispenses after the dispense weight verification completes or “-1” if the routine fails or is interrupted before it completes.</p> <p>Valid only after collection event “DispenseWeightComplete” occurs.</p>
500	DV	F4	<p><u>ConveyorSpeed1</u>. This is the Conveyor 1 belt speed in in./sec. when it is moving a board to the next dispensing position.</p>
501	DV	F4	<p><u>ConveyorSpeed2</u>. This is the Conveyor 2 belt speed in in./sec. when it is moving a board to the next dispensing position.</p>
600	EC	Bool	<p><u>PurgeEnabled1</u>. This Boolean flag indicates whether periodic purging operations are enabled for Valve 1.</p>
601	EC	Bool	<p><u>MeasFlowEnabled1</u>. This Boolean flag indicates whether periodic flow rate calibration operations are enabled for Valve 1.</p>
602	EC	Bool	<p><u>PurgeEnabled2</u>. This Boolean flag indicates whether periodic purging operations are enabled for Valve 2.</p>
603	EC	Bool	<p><u>MeasFlowEnabled2</u>. This Boolean flag indicates whether periodic flow rate calibration operations are enabled for Valve 2.</p>
610	EC	U4	<p><u>BOARDFREQUENCY</u>. This value is set by the station controller to the board frequency it requires collection event 2010 to occur.</p> <p>The default is zero which prevents collection event 2010 from triggering.</p>
611	EC	Bool	<p><u>TEMPERATUREDVUPDATE</u>. Set by the station controller to turn heater temperature data variable updating on (TRUE) or off (FALSE). The default value is TRUE.</p>
700	SV	U2	<p><u>CameraXFieldMils</u>. The size in mils of the X coordinate axis field of view seen by the camera.</p>
701	SV	U2	<p><u>CameraYFieldMils</u>. The size in mils of the Y coordinate axis field of view seen by the camera.</p>

Table A-1 Data Dictionary Variables (continued)

VID	Class	Format	Name and Description
801 to 817	DV	F8	<p><u>TEMPHTR1CHAN1 – TEMPHTR1CHAN17</u>. Heater 1 temperatures for channels 1-17 respectively (DV 801 = channel 1, DV 802 = channel 2, etc.).</p> <p>The units are in degrees. No other information is supplied such as the unit of degrees (°C or °F) or what device the channel is mapped to (i.e., pre-dispense station, needle heater, etc.). A value of negative one (-1) indicates the channel is not monitored or not turned on.</p> <p>Note: These variables are only updated between boats and only when monitored by “Verify Temperature Before Initial Dispense”.</p>
818 to 834	DV	F8	<p><u>TEMPHTR2CHAN1 – TEMPHTR2CHAN17</u>. Identical to Data Variables 801-817 except that they refer to Heater 2 channels 1-17, respectively (DV 818 = channel 1 of Heater 2, DV 819 = channel 2 of Heater 2, etc.).</p>
835 to 851	DV	F8	<p><u>TEMPHTR3CHAN1 – TEMPHTR3CHAN17</u>. Identical to Data Variables 801-817 except that they refer to Heater 3 channels 1-17, respectively (DV 835 = channel 1 of Heater 3, DV 836 = channel 2 of Heater 3, etc.).</p>
1000	DV	A[0-40]	<p><u>ALARMTEXT</u>. The Alarm Text (ALTX) for the most recently transitioned Alarm.</p>
1001	DV	Bool	<p><u>ALARMSEVERITYCODE</u>. The Severity Code (ALCD low-order 7 bits) for the most recently transitioned alarm.</p>

Appendix B – Collection Events

Table B-1 lists the collection events that exist at the Equipment.

Table B-1 CEID

CEID	Name	Description
Note: CEID 1 – 65 are standard GEM		
1	ControlStateChange	Event is triggered when there is a change in control state.
2	ProcessStateChange	Event is triggered when there is a change in process state.
3	GemPPChangeEvent	Event is triggered when the Operator creates, changes, or deletes a process program.
4	OperatorCommand	Sent whenever the Operator attempts to control the machine while in the Online - REMOTE state.
5	AbortStarted	Event is triggered when an abort request was acknowledged and the abort process begins.
6	AbortCompleted	Event is triggered when the abort process is complete.
7	GemBadDownloadEvent	After the host downloads a recipe to the equipment upon the equipment's request, the equipment checks the recipe for accuracy. If the process program is invalid, event is triggered.
8	GemControlStateLOCAL	Sent when Control State changes to LOCAL.
9	GemControlStateREMOTE	Sent when Control State changes to REMOTE.
14	StartCmd	Sent when the Operator clicks the GO button from Teach Window or Run Window.
15	StopCmd	Sent when the Operator clicks the STOP button from Teach Window or Run Window.
16	PauseCmd	Sent when the Operator clicks the PAUSE button from Teach Window or Run Window and the equipment is in RUNNING state.
17	ResumeCmd	Sent when the Operator clicks the PAUSE button from Teach Window or Run Window and the equipment is in PAUSED state.
18	AbortCmd	Sent when the Operator clicks the ABORT button from Teach Window or Run Window.
20	EqConstChange	Sent to the Host when the Operator changes an Equipment Constant.
21	S10Ack	Sent to acknowledge the reception of a Host text message.
22	GemEquipmentOFFLINE	Sent when Control State changes to Off-Line.
23	GemSpoolingActivated	Sent when Equipment attempts to send a primary message to the Host and gets a transmit failure while Spooling is enabled.
24	GemSpoolingDeactivated	Sent after the entire spool file has been read by the Host.
25	GemSpoolTransmitFailure	Sent if a transmission failure occurs during the period in which the Host is reading the Spooling file.

Table B-1 CEID (continued)

CEID	Name	Description
Board Handling		
2001	BoardAtDispenseLoc1	The board is at the dispensing location for Conveyor 1 and ready for dispensing.
2002	DispensingDone1	Dispensing is completed for Conveyor 1. The board is ready to leave the dispensing location.
2003	BoardAtDispenseLoc2	The board is at the dispensing location for Conveyor 2 and ready for dispensing.
2004	DispensingDone2	Dispensing is completed for Conveyor 2. The board is ready to leave the dispensing location.
2010	BoardFrequencyDataUpload	Collection event that is generated per boat count during a production run. The boat count is specified by equipment constant 610.
2050	BarcodeRead	Sent to the host after a barcode has been successfully read. This event will occur after events BoardAtDispenseLoc1 and BoardAtDispenseLoc2.
2051	MachineEmpty	Sent to the host when the machine has set idle waiting for a board after a user configurable timeout.
File Handling		
3001	NewProgramLoaded	A new program is loaded.
3002	NewFluidFileLoaded1	A new fluid parameter file for Valve 1 is loaded.
3003	NewHeaterFileLoaded	A new heater parameter file is loaded.
3004	FluidParametersModified1	The fluid parameters for Valve 1 have been changed by an operator.
3005	FluidParametersSaved1	The fluid parameters for Valve 1 have been saved onto the local mass storage.
3008	ConveyorCodeDownloaded1	A new conveyor control code has been downloaded into the Conveyor 1 controller.
3009	NewFluidFileLoaded2	A new fluid parameter file for Valve 2 is loaded by an operator.
3010	FluidParametersModified2	The fluid parameters for Valve 2 have been changed by an operator.
3011	FluidParametersSaved2	The fluid parameters for Valve 2 have been saved onto the local mass storage.
3012	ConveyorCodeDownloaded2	A new conveyor control code has been downloaded into the Conveyor 2 controller.

Table B-1 CEID (continued)

CEID	Name	Description
Setup		
4001	PromptedSetupStarted	An operator has initiated the Prompted Setup process.
4002	PromptedSetupCompleted	The Prompted Setup Process is completed.
4003	FindNeedleXYZ	An automatic needle XYZ calibration has been performed.
4004	ManualMeasureFlowRate1	A flow rate measurement for Valve 1 has been initiated by an operator.
4005	ManualPurgeNeedle1	A needle purging of Valve 1 has been initiated by an operator.
4006	OperationLevelChanged	The system operation level has been changed.
4007	PasswordsModified	The system operation level passwords have been modified.
4008	ManualMeasureFlowRate2	A flow rate measurement for Valve 2 has been initiated by an operator.
4009	ManualPurgeNeedle2	A needle purging of Valve 2 has been initiated by an operator.
4010	ScaleRead1	The Scale has been read after Valve 1 has dispensed material during the Dispense Weight Verification Procedure. Data Variable ScaleMeasurement1 holds the scale measurement.
4011	ScaleRead2	The Scale has been read after Valve 2 has dispensed material during the Dispense Weight Verification Procedure. Data Variable ScaleMeasurement2 holds the scale measurement.
4012	FlowRate1Updated	The Flow Rate for Valve 1 has been updated (Data Variable FlowRate1 has been modified).
4013	FlowRate2Updated	The Flow Rate for Valve 2 has been updated (Data Variable FlowRate2 has been modified).
4020	DispenseWeightComplete	Collection event that is generated upon completion of all dispenses during the Dispense Weight Verification routine. See related data variables: DWVRESULT DWVVALVE DWVTARGET DWVDISPENSES DWVTARGETRANGE DWVTARGETMINLIMIT DWVTARGETMAXLIMIT DWVMEASUREDRANGE DWVMEASUREDAVG

Table B-1 CEID (continued)

CEID	Name	Description
Run Time		
5001	HeaterMonitorTimeout	The heaters at the dispensing location failed to reach the specified temperature range within the timeout period.
5002	HeaterMonitorSkipped	The Operator has selected to skip the temperature monitoring and proceed to dispensing.
5003	HeaterMonitorAborted	The Operator has selected to abort the temperature monitoring and aborted the run.
5004	PeriodicPurge1	A periodical purging of the needle for Valve 1 has been performed.
5005	PeriodicFlowrateMeasurement1	A periodical flow rate measurement for Valve 1 has been performed.
5006	PotLifeWarning1	The pot life of the dispensing material for Valve 1 has reached a warning level.
5007	PotLifeExpire1	The pot life of the dispensing material for Valve 1 has expired.
5008	AwaitingRecoveryCommand	The system has queried the Operator to recover the previous run.
5009	OperatorAckedTerminalMsg	The Operator acknowledged a terminal message.
5010	PeriodicPurge2	A periodical purging of the needle for Valve 2 has been performed.
5011	PeriodicFlowrateMeasurement2	A periodical flow rate measurement for Valve 2 has been performed.
5012	PotLifeWarning2	The pot life of the dispensing material for Valve 2 has reached a warning level.
5013	PotLifeExpire2	The pot life of the dispensing material for Valve 2 has expired.
Errors		
9000	FMWError	A Fluidmove error has occurred. Use status variable FMWMostRecentError (1002) to retrieve the error code.
9001	FMWErrorCleared	A Fluidmove error has been acknowledged by the Operator and the message cleared.

Appendix C – Alarms

Since the number of alarms that Fluidmove reports to SECS/GEM is constantly growing, each individual alarm will not be listed here. The alarm section of the GWGEM GCD file is automatically generated from the Fluidmove source code using a custom software tool. Use the SECS/GEM message S5F5 to retrieve a list of all alarms currently reported by your version of Fluidmove.

The format for each alarm is described below:

- ALID** Alarm ID. This number is the same as the resource identification number used by Fluidmove.
- ALCD** Alarm Severity Code. The low-order 7-bits of ALCD specifies the severity code. The high-order bit (bit-8) shows the current alarm state (1=SET, 0=CLEAR). Currently all Fluidmove errors have a default severity code of 64.
- ALTX** Alarm Text. This is the actual string sent to the Host in the Alarm Report (S5F1) and is a truncated version (first 40 characters) of the resource item used by Fluidmove.
- ON CEID** This is the Collection Event that is signaled when the alarm state changes from CLEAR to SET ("going-on"). For all of the Fluidmove errors the event is FMWError.
- OFF CEID** This is the Collection Event that is signaled when the alarm state changes from SET to CLEAR ("going-off"). For all of the Fluidmove errors the event is FMWErrorCleared.

Table C-1 provides some examples of common alarms and how the ALID, ALCD, ALTX, and ON/OFF CEIDs related to them.

Table C-1 Alarms

ALID	ALCD	ALTX	Alarm Description	ON CEID	OFF CEID
4	64	Heater Temperature is Too Low	Current Temp < setpoint - band	9000	9001
5	64	Heater Temperature is Too High	Current Temp > setpoint + band.	9000	9001
30002	64	Run Aborted	The currently running program has been aborted.	9000	9001
30167	64	Error during fiducial finding	An error occurred during the fiducial finding process.	9000	9001
30172	64	Loss of air pressure detected	Fluidmove has detected low air pressure.	9000	9001

Glossary

Alarm	An alarm is related to any abnormal situation on the Equipment that may endanger people, Equipment, or material being processed. GEM allows the Host to be notified when alarm conditions are detected and cleared.
ALID	Equipment Alarm ID
CEID	Collection Event ID
Collection Event	A collection event is a detectable occurrence significant to the Equipment that is considered to be significant to the Host. GEM allows the Host to be notified when a collection event occurs. This allows the Host to track the Equipment's activity.
Data Values	Also known as Discrete Data. Meant to be temporary or ephemeral statuses that disappear after an event is complete. Sometimes known as 'DVs' (Data Values), 'DVVALs' (Discrete Data Values).
Data Variable (DV)	Data variables may only be valid upon the occurrence of a particular event. The Host may gather data variable values from the GEM Equipment.
Equipment	An intelligent system which communicates with a Host and complies with the GEM standard. In this manual it refers to an Asymtek dispensing system.
Equipment Constant (EC)	Equipment Constants are settable by the Host. The Host may gather Equipment constant values from the GEM Equipment. The Host may also set Equipment constant values on the GEM Equipment to control the Equipment's behavior.
Fluidmove	The Fluidmove [®] for Windows NT [®] or Fluidmove [®] for Windows XP [®] software application which controls GEM.
GCD	GWGEM Configuration Data (an ASCII file compiled for GWGEM).
GEM	Generic Equipment Model. The GEM (E30) standard defines the generic behavior of semiconductor Equipment as viewed through a communications link in terms of SECS-II messages communicated over that link. The GEM standard impacts Equipment control and Equipment-to-Host communications.
High-Speed SECS Message Services (HSMS)	<p>HSMS (E37) is a high-speed replacement and an alternative to SECS-I for applications where higher speed communication is needed or where simple point-to-point technology is insufficient.</p> <p>HSMS defines a communication interface via TCP/IP suitable for the exchange of (SECS-II) messages between computers in a semiconductor factory.</p>
Host	The computer which is connected to, and communicates with, the Equipment via the SECS interface. The GEM standard defines a set of messages the Host must use when interacting with the Equipment. The Equipment communicates with one Host, but the Host may communicate with multiple Equipment units.

HSMS-GS	High Speed Message Service-General Session. This standard defines TCP/IP network communication used by GEM for Host/Equipment communication. It is intended to be applied for complex systems containing multiple independently accessible subsystems and uses an extended state machine.
HSMS-SS	High Speed Message Service-Single Session. This standard defines TCP/IP network communication used by GEM for Host/Equipment communication. It replaces the SECS-I standard.
ID	Identifier or Identification.
Operator	The person who physically has access to the Equipment's material port(s) and control panel. This is the person who is operating the dispensing system.
PP	Process Program
Recipe	A file containing a set of instructions for the Equipment.
Report	A set of variables predefined by the Equipment or defined by the Host. The Host uses reports to gather status variable, data variable, and Equipment constant values. The Host may request a report explicitly or attach a set of reports to a collection event.
SECS	SEMI Equipment Communications Standard. <u>SECS I (E4)</u> : SEMI Equipment Communications Standard 1 Message Transfer. Defines RS-232 serial communication used by GEM for Host/Equipment communication. <u>SECS II (E5)</u> : SEMI Equipment Communications Standard 2 Message Content. A standard for communications between intelligent Equipment and a Host. The standard defines the communication protocol interface (SECS-I) and the messages exchanged (SECS-II).
Message	All GEM Equipment and Host communication is accomplished using SECS-II messages. Each unique SECS-II message is identified by its stream number (S) and function number (F). The SECS-II standard defines a large set of SECS-II messages determining each one's purpose, content, and usage. The GEM standard defines how to use a subset of these SECS-II messages yet allows other SECS-II messages to be used in addition to this subset.
SEMI	Semiconductor Equipment and Materials International (SEMI) is a global trade association that represents the semiconductor and flat panel display equipment and materials industries. SEMI maintains and publishes standards that relate to Equipment automation and software.
Status Variable (SV)	Status Variable. Status variables may include any parameters that can be sampled in time such as temperature or quantity of a consumable. The Host may gather status variable values from the GEM Equipment.
UFPP	Unformatted Process Program
VID	Variable Identifier. A unique string representing the name of a variable.