



DP-3000 Series

**Linear
Dispensing Pump
Upgrade Kit**

Owner's Manual

P/N 7206913, Revision A

NOTICE

This is an Asymtek publication, which is protected by copyright. Original copyright date 2005. No part of this document may be photocopied, reproduced, or translated to another language without the prior written consent of Asymtek. The information contained in this publication is subject to change without notice.

Manuals on the Internet

For the convenience of Asymtek customers and field service representatives, copies of this manual can be downloaded from:

<http://www.asymtek.com/support/manuals.htm>

Contact Us

Asymtek welcomes requests for information, comments, and inquiries about its products. General information about Asymtek can be found on the Internet at www.asymtek.com.

Asymtek	
Headquarters	2762 Loker Avenue West Carlsbad, CA 92010-6603 USA
Toll Free:	1-800-ASYMTEK (1-800-279-6835)
Tel:	+1-760-431-1919
Fax:	+1-760-431-2678
E-mail:	info@asymtek.com
Website:	www.asymtek.com
Technical Support	
USA:	1-800-ASYMTEK (1-800-279-6835)
Other regions:	www.asymtek.com Tech Support

Trademarks

Asymtek® and Fluidmove® are registered trademarks of Asymtek.

Loctite Removable Threadlocker #242 is a registered trademark of Loctite Corporation.

Teflon is a registered trademark of E.I. DuPont.

©Asymtek 2005

1 Introduction

Pumps

DP-3000 series pumps are designed so that you can easily convert the pump to another model or add options. The interchangeable parts are:

- Motor type (including upgrade to encoder control)
- Chamber size
- Gear ratio

This section provides procedures for performing the upgrades listed above. You can convert the DP-3000 to another model by changing the drive motor. You can also use the same procedure to replace the drive motor if it fails. If you want to order new parts to make any of these changes, please contact Asymtek.

DP-3000 Drive Motor Upgrade

The SDP-3XX1, SDP-3XX2, and SDP-3XX4 Motor Upgrade Kits allow you to convert the model of the pump by changing the motor model. For example, if can convert a DP-3XX2 model pump into a DP-3XX4 model pump, and vice versa. Converting from one pump to another can radically change the flow rate performance of the pump.

There are three motors that can be easily interchanged and used on the DP-3000. The type of motor used directly affects the flow rate, and each model is most useful for specific applications within the range of dot accuracy indicated in Table 1-1. Motor upgrade kits are available through Asymtek.

Table 1-1 Motor Speeds by Type

Model	Type	Value	Color
DP-3XX1	Very slow motor	369:1 ratio	Green
DP-3XX2	Slow motor	84:1 ratio	Grey
DP-3XX4	Fast motor	19:1 ratio	Black
DP-3XX0	All speeds (encoded)	19:1 ratio	Black
DP-3XX0-02	Low speeds (encoded)	84:1 ratio	Blue



NOTE When you order your kit, make sure to specify that you will be performing a drive motor upgrade.

The encoded motor (SDP-3XX0) is a specialized, board-driven model that requires special electronics drivers for operation. A trained Asymtek service technician **MUST** install this model to allow you to make use of its features. Refer to the Introduction section of this manual for a description.

It may be necessary to change the drive motor if the present one is damaged or if you wish to use your DP-3000 for an application requiring a different dispensing speed. Whether you are upgrading your drive motor or simply replacing it, follow the instructions below for removing and replacing the drive motor.

2 Upgrading the DP-3000

Changing the Motor

This section provides instructions for removing and installing a motor.



CAUTION!

The Motor Encoder Assembly is a delicate assembly. Failure to handle the assembly with care will jeopardize the functionality of the assembly.

Tools Needed

- 5/64-inch hex key
- 3-mm hex key
- 2.5-mm hex key
- 2-mm hex key
- 1/16-inch hex key
- Loctite Removable Threadlocker #242[®] or equivalent

Removing the Drive Motor

Refer to Figure 2-1, Figure 2-2 and Figure 2-3 for the following procedure.

To remove the drive motor:

1. Move the dispensing head to the front center of the dispensing area.
2. Disconnect the fluid reservoir hose from the pneumatic line.
3. Twist the Luer elbow off of the stopcock.
4. Remove the fluid reservoir from the clip.
5. Disconnect all pump power cables and pneumatic hoses.
6. Remove the pump from the dispensing system.
7. Using a 2.5-mm hex key, remove the three screws from the gear cover.
8. Remove the gear cover.
 - ▶ The gears will now be exposed.
9. Remove the main cover.
 - ▶ The motor gear, feed screw gear, and valve control PCA will now be exposed. See Figure 2-1.
10. Disconnect the red connector from the valve control PCA. See Figure 2-2.
11. Using a 2.5-mm hex key, remove the motor cable clamp.
12. Using a 1/16-inch hex key, remove the set screw from the motor gear.
13. Gently but firmly lift the motor gear off of the shaft, and place it aside.
14. Using a 2-mm hex key, remove the three screws from the motor mount.
15. Gently pull down on the motor, and lift it out of the pump. See Figure 2-3.

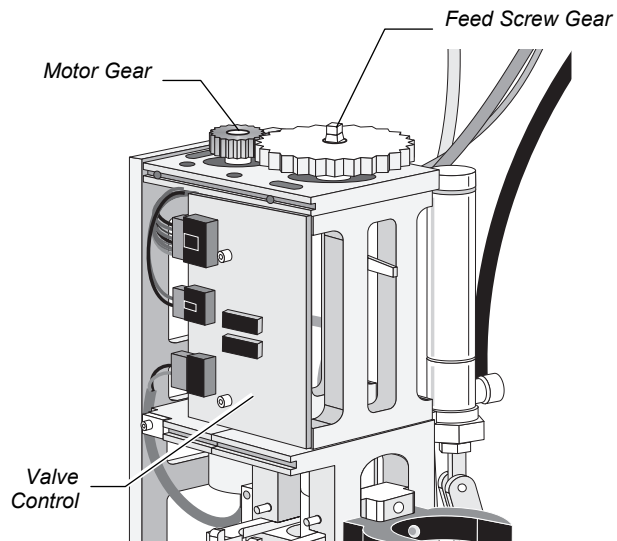

Figure 2-1 DP-3000 with Main and Gear Covers Removed

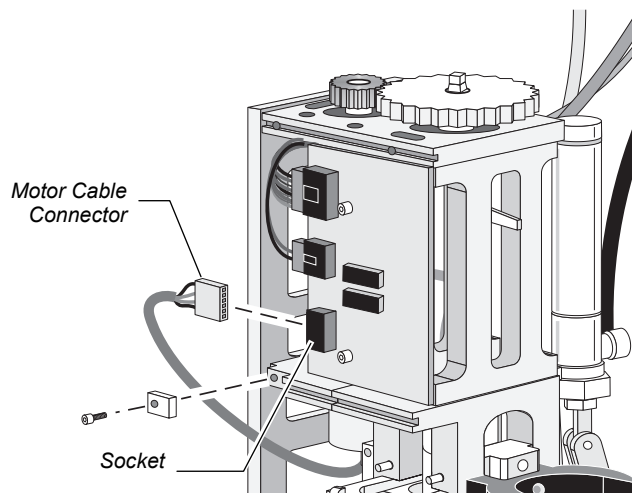

Figure 2-2 Disconnecting the Motor Cable and Clamp

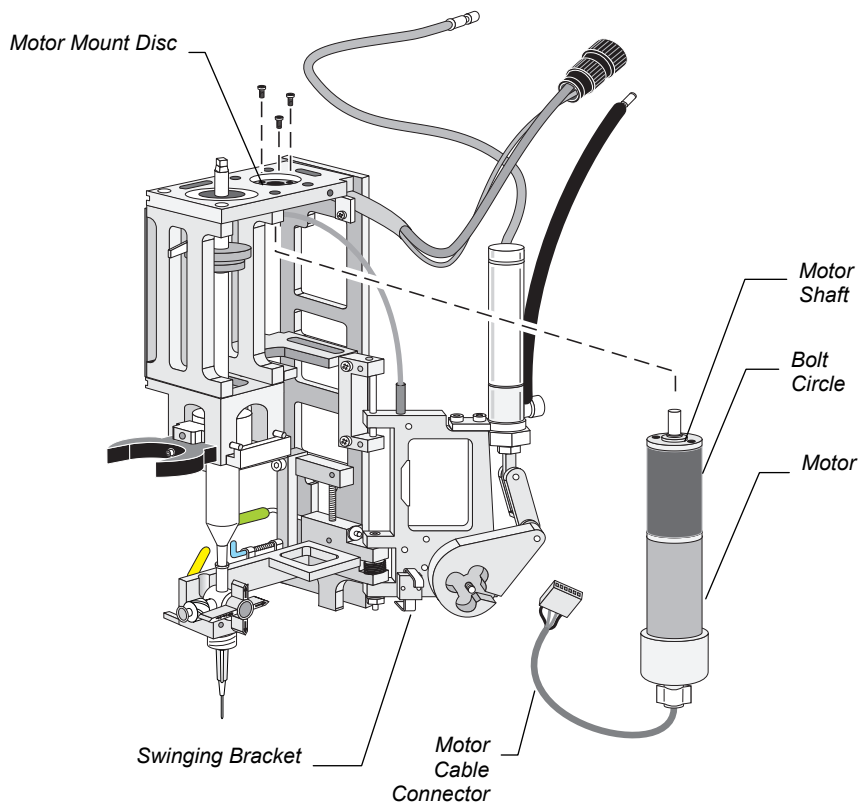

Figure 2-3 DP-3000 with Motor Removed

Installing the Motor

Refer to Figure 2-2 and Figure 2-3 to locate parts.

To install the new motor:

1. With the swinging bracket open, slide the new motor into the back of the DP-3000.
2. Rotate the motor mount disc so that the bolt circle lines up with the bolt circle on the motor.
3. Install the three screws onto the motor mount, and use the 2.5-mm hex key to tighten them.



NOTE It is recommended that you use Loctite Removable Threadlocker #242 when replacing these screws to prevent them from loosening when the pump vibrates.

4. Replace the motor gear onto the motor shaft.
 - ▶ Align the hole in the motor gear with the flat part of the motor shaft.
5. Insert the set screw into the motor gear.
6. Align the motor gear so that it is exactly the same height as the feed screw gear.



CAUTION!

It is important that the gears are properly aligned for the pump to function correctly. Gears that are not aligned to the same height may shear, causing damage to the pump.

7. Using a 1/16-inch hex key, tighten the motor gear set screw.
8. Connect the red motor cable connector to the red socket on the valve control PCA. See Figure 2-2.
 - ▶ Make sure that all PCA connections are tight.
9. Replace the main cover, and secure it with the three screws.
10. Replace the gear cover, and secure it with the three screws.
11. Reinstall the DP-3000 on the dispensing system.
 - ▶ Refer to the *DP-3000 Owner's Manual* for instructions.

Changing the Chamber Size

There are two available chamber sizes for use with the DP-3000: 1-cc and 2-cc. You can order conversion kits, which enable you to convert the pump between the two sizes. The part numbers for the kits are SDP-3X2X (1-cc) and SDP-3X4X (2-cc). (The approximate, calculated chamber volumes are: 1-cc = 1.107 cc and 2-cc = 2.492 cc.)



NOTE When you order a kit, you must specify that you want to perform a chamber upgrade. The receiver block, piston and pumping chamber must all match. Mismatching the items may result in damage to the pump. Parts that must match are identified below.

Each chamber kit includes a piston that corresponds with the chamber size. Changing the piston will have a significant effect on the flow rate, and you may need to change other components as well to accommodate the new chamber size. If the chamber does not fit snugly into the receiver block with a slight resistance, it is the wrong size. The size of the receiver block is stamped into the part. There should also be a slight resistance when you slide the receiver slide over to lock the chamber into place. If the piston is too large, it will not fit through the pumping chamber. However, a piston that is too small for the pumping chamber will cause leakage into the assembly during dispensing. Leakage into the assembly may also be caused by a missing seal or O-ring. Refer to the *DP-3000 Owner's Manual* for troubleshooting instructions.

Tools Needed

- 2.5-mm hex key
- Piston extraction tool
- Adjustable wrench or 5/8" socket and ratchet
- Chamber upgrade kit
- Thread sealant or Teflon tape

To replace the chamber:

1. Remove the fluid reservoir.
2. Remove the pumping chamber and stopcock.
3. Using a small hex key, remove the receiver assembly pins. See Figure 2-4.

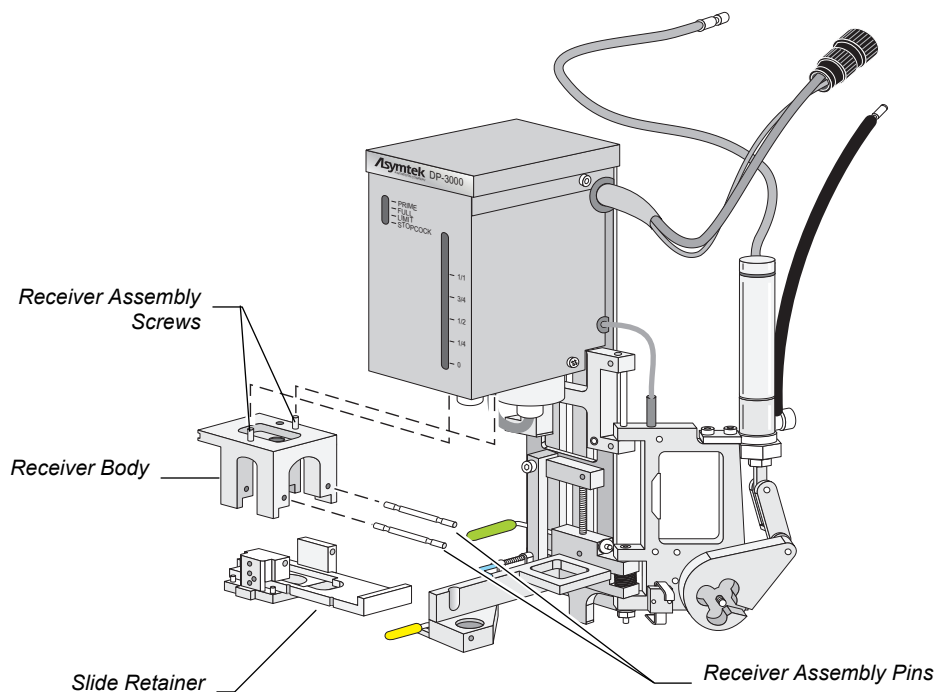

Figure 2-4 Removing the Receiver Body

4. Pull gently down on the slide retainer to remove it.
5. Using the 2.5-mm hex key, loosen the two assembly screws that attach the receiver block to the pump.
 - ▶ These screws are captive and should remain attached.
6. Pull the receiver body gently downward, and remove it.

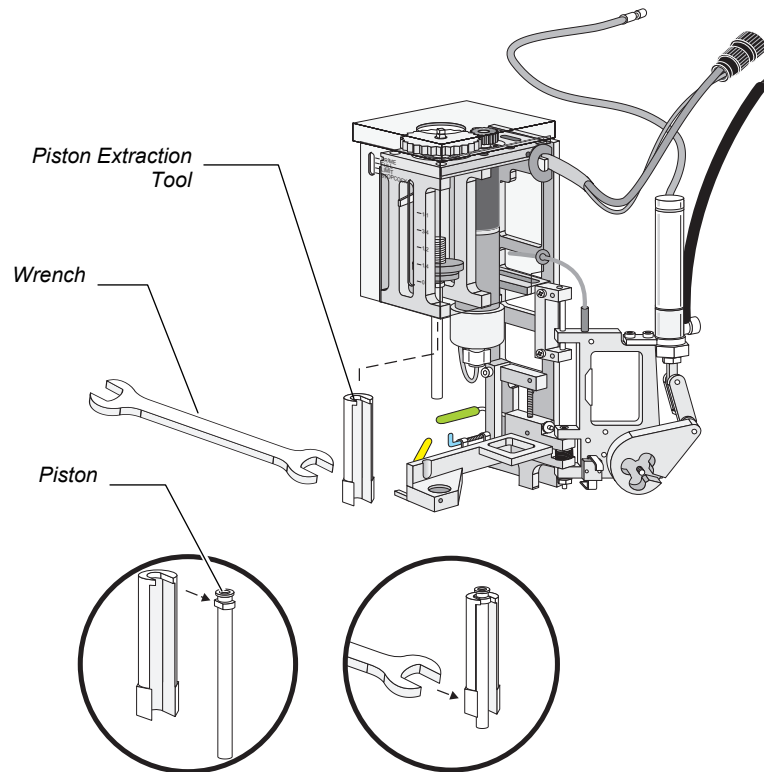

Figure 2-5 Using the Piston Extraction Tool

7. Place the piston extraction tool around the piston, aligning the flats on the piston with the opening on the beveled end of the piston extraction tool. See Figure 2-5.



NOTE The piston must be fully extended for removal and installation. To fully extend the piston, perform steps 8–11.

8. Click on **Run a Program** in the Fluidmove Main Window.
9. Click on **Setup**.
10. From the **Setup** menu, double-click on **Purge Infinite**.
 - ▶ If you have removed the pump from the dispensing system, you can use the upper knob to extend the piston instead of performing the following procedure.
 - ▶ If you do not see **Purge Infinite** in the **Setup** menu, you will need to perform the following instead:
 - a. Return to the Main Window.
 - b. Click on **Configuration**.

- c. Select **Setup Purge Station**.
 - d. Make sure that the checkbox labeled Timed Purge is NOT checked.
 - e. Click on **Purge**.
11. Press **OK**.
 12. Using the adjustable wrench, turn the piston tool, and remove the piston.



NOTE The dispensing system interlocks must be disabled or the doors must be closed when you click **Purge**.

- See the *DP-3000 Owner's Manual* for a description of DP-3000 commands.
- The piston will fully extend from the pump body and stop at the bottom of its travel.
- A dialog box opens indicating "DP-3000 out of travel limits".

Alternately, you can use a 5/8-inch socket and ratchet. Place thread sealant or Teflon tape around the piston threads to protect the lead screw from fluid leakage into the receiver block.



CAUTION!

Failure to properly seal the piston threads could cause irreparable damage to the pump if the priming O-ring is not in place, causing fluid to leak into the receiver block. The fluid could cure around the lead screw, preventing it from movement.

13. Place the piston extraction tool around the new piston, and place both into the pump. Fit the receiver body around the piston.
14. Using the 2.5-mm hex key, tighten the screws.
15. Install the slide retainer onto the receiver block, and secure it with the receiver pins.
 - ▶ You will hear an audible click when the pins are correctly installed.
16. Refer to the *DP-3000 Owner's Manual* for instructions on reinstalling the pumping chamber.

Changing Gears

You can modify the DP-3000 flow rate by interchanging the gear sizes within a given gear box for your motor. Gear ratio adjustment allows you to change the speed of the lead screw to optimize the flow rate for your application. There are three possible gear ratio combinations available:

24/56

56/24

40/40

These figures indicate the number of teeth on each gear. These configurations may be used with any motor type to modify the speed range. Either the motor gear or the feed screw gear may be size 24, 40 or 56 to form one of the combinations above. The gear size directly affects the rate of linear travel of the lead screw, which controls the piston speed when dispensing (forward movement) and refilling (reverse). A smaller motor gear will cause the lead screw and piston to move more slowly, resulting in a lower flow rate. A larger motor gear will have the opposite effect.



CAUTION!

Removal of the pump is not required. However, if the pump is not completely removed, the dispensing system should be turned OFF to avoid injury. Only a trained service technician should change the gear box.

Tools Needed

- 2.5-mm hex key
- 1/16-inch hex key

To change the gears:

Refer to Figure 2-6 and Figure 2-7 to locate parts.

1. If a fluid reservoir is installed, disconnect it from the pneumatic line.
2. Remove the fluid reservoir from the DP-3000 by disconnecting the Luer elbow from the stopcock and unclipping it.
 - ▶ You may want to remove the receiver head from the fluid reservoir first.
3. If desired, remove the DP-3000 from the dispensing system.
4. Using the 2.5-mm hex key, remove the three screws from the gear cover.
5. Remove the gear cover. See Figure 2-6.
 - ▶ The gears will now be exposed.
6. Using the 1/16-inch hex key, loosen the set screws on the gears. See Figure 2-7.
7. Gently but firmly, lift the gears off of the shafts to remove them.
8. Place the replacement gears on the respective shafts.
9. Align the set screw hole on the feed screw gear with the long flat on the feed screw shaft, and use the 1/16-inch hex key to tighten it.
 - ▶ It is easiest to place the set screw onto the end of the hex key, then place the end of the hex key into the hole on the feed screw gear.
10. Align the set screw hole on the motor gear with the flat of the motor shaft.
 - ▶ Do not yet tighten the set screw.

11. Position the gears so that they are the same height.



CAUTION!

It is important that the gears are properly aligned for the pump to function correctly. Gears that are not aligned to the same height may shear, causing damage to the pump.

12. When the gears are properly positioned, use the 1/16-inch hex key to tighten the set screws in the gears.
13. Replace the gear cover and gear cover screws.

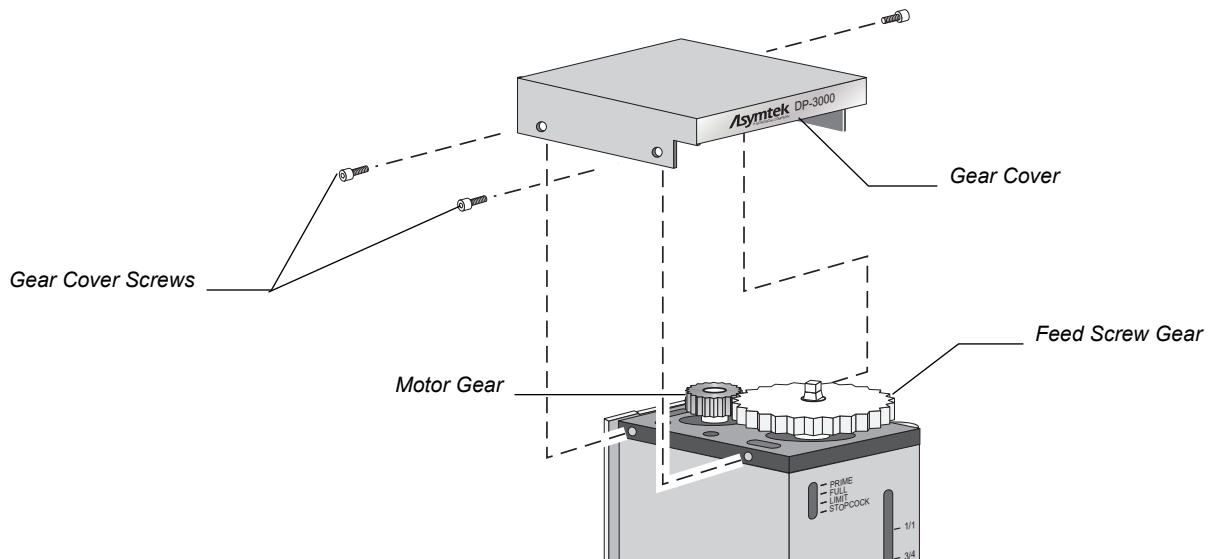

Figure 2-6 Removing the Gear Cover

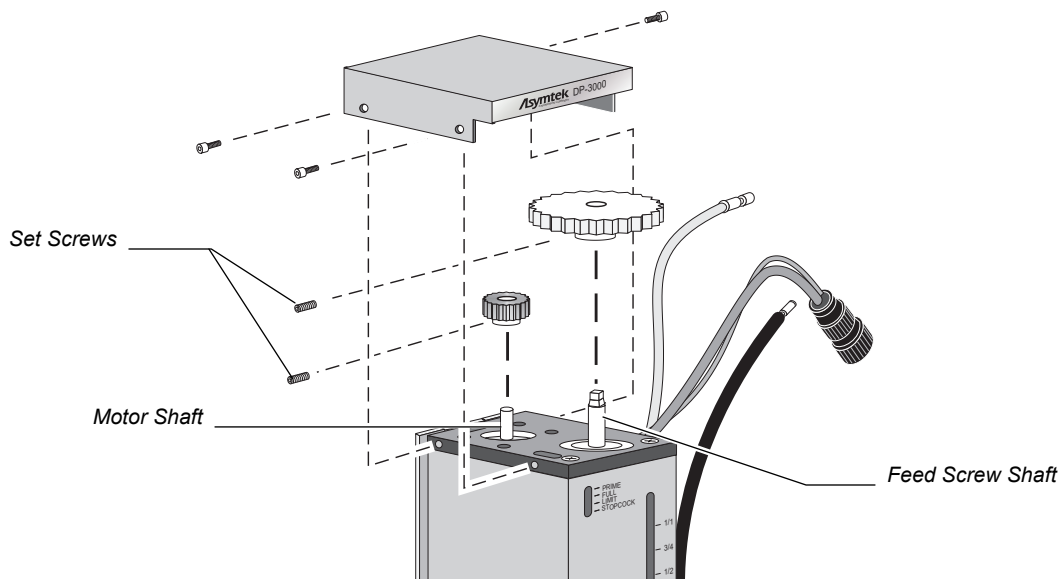

Figure 2-7 Removing the Gears



Asymtek Headquarters
2762 Loker Avenue West
Carlsbad, CA 92010-6603 USA
Tel: (760) 431-1919
1-800-ASYMTEK (1-800-279-6835)