

Spectrum™ S-920N Series

Scalable solutions for high-volume manufacturing and assembly

Features and Benefits

- **The S-920N series leverages over 25 years of Nordson ASYMTEK automated fluid dispensing and jetting technology**
- **Scalable design matches current *and* future requirements for maximum return on investment**
- **Software-controlled features improve yield, minimize operator intervention, and enable complete recipe transfer to other sites**
- **A flexible number of heating zones with optional Controlled Process Heat (CpH) minimizes processing time**
- **MH-900 series loaders/unloaders can be added to create an island of automation or for inline production capability**

The scalable Spectrum™ S-920N series with Fluidmove®XP (FmXP) software is ideal for high-volume microelectronics manufacturing and PC board assembly such as flip chip and CSP underfill.

Scalability. With its flexible, scalable configuration, the S-920N can be configured with single or dual lanes, and up to six heat stations with the dual lane configuration. The platform is easily upgraded when process needs change.

The S-920N maximizes use of floor space — it is 600 mm wide (without the optional pre- and post-heat stations), half the width of other dispensers on the market.

Advanced Process Control. The S-920N reduces process variation, increases yield, and reduces cost. Software-managed temperature, fluid and air pressure provide closed-loop control that eliminates the need for operator adjustment. Calibrated Process Jetting (CPJ) automatically maintains volumetric repeatability during long production runs. Controlled Process Heat (CpH™) adds recipe-controlled heat management for improved thermal efficiency.

The Spectrum's digital vision system with dual-color, adjustable on-axis lighting offers fast and reliable image acquisition.



Adding the Fids-on-the-Fly™ option accelerates fiducial capture, and laser height sensing further reduces time spent on non-dispense routines.

Jet Technology. Patented non-contact jetting offers many advantages over traditional needle dispensing. The DispenseJet® valve shoots “on the fly” using a patented high-speed mechanism, jetting precise volumes of fluid in dots, lines and patterns with flow rates up to 500 mg/second and 200 dots/second. Jetting overcomes the limitations of needle dispensing — no bent needles, no chipped die, no dripping, less sensitivity to surface height variations — and has the ability to dispense material into tight spaces without slowing down.

Value. With a reputation for innovation, comprehensive process solutions from Nordson ASYMTEK ensure a maximum return on investment and low cost of ownership. From initial process development through full scale production, you are supported by our experienced worldwide engineering, applications development and technical service network.



S-920N Series Features

Standard features

Calibration module: patented Mass Flow Control Module with scale, vacuum purge, and fiducial marks for automatic setup

CPJ – Calibrated Process Jetting

Digital vision system

Light beacon with audible alarm

Low pressure sensor

Programmable fluid and valve pressure

Tactile height sensor

Ventilation exhaust system

Optional features

CpH™ - Controlled Process Heat

Contact or impingement heat tooling

Dual valves: dual action (two applicators operate independently); dual simultaneous (two applicators on one synchronous head)

Dual-lane configuration – Model S-922N

Exterior bulk fluid reservoir: 600 cc (20 oz), includes remote feed and fluid level sensor

Fids-on-the-Fly™

Laser height sensor

Low fluid sensor (magnetic or capacitive)

Material handling: MH-900 Series loader/unloaders, film frame wafer, bare wafer

Pre- and post-heat stations

Process development hot plate (S-920N only)

SECS/GEM interface

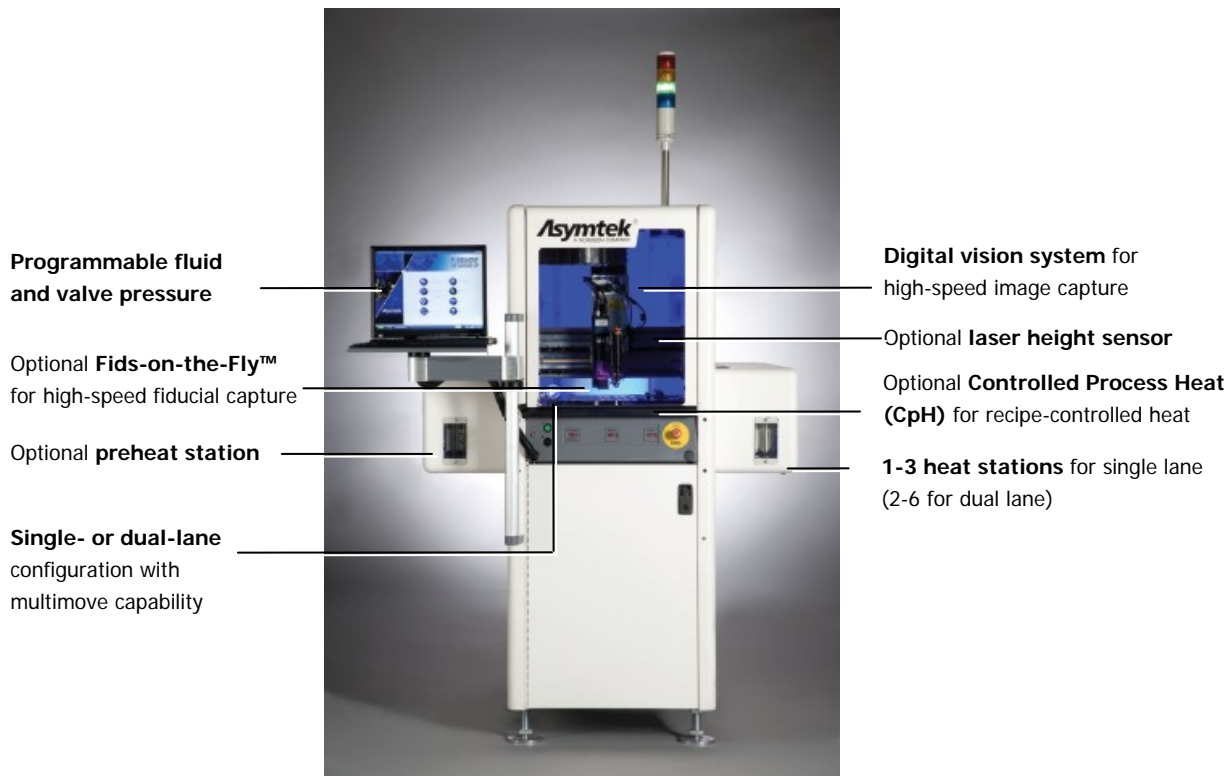

Why choose Nordson ASYMTEK? Customers have told us:

- Best cost-of-ownership per square meter: the Spectrum system occupies less footprint with higher cycle time reductions over other systems
- Outstanding applications expertise and experience
- Technical skills and professionalism of the applications and engineering teams
- Willingness and ability to develop robust custom-engineered solutions

Lower Your Cost of Ownership

The Spectrum S-920N series lowers cost of ownership with:

- A smaller footprint frame
- Flow-rate monitoring to minimize material waste and increase process yield
- Tight temperature control using software-managed jet/needle heaters
- Fast non-contact jetting that reduces yield loss associated with needle dispensing
- Dual lane conveyors (S-922N) for higher throughput or feeding a dual-lane placement system without need of a shuttle

Key Features for Enhanced Throughput and Process Control

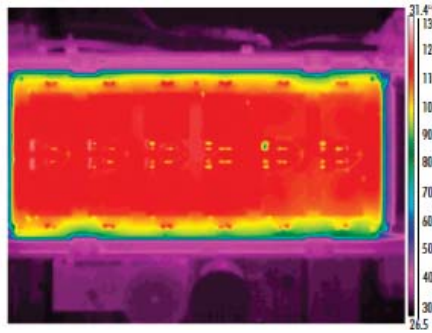

Infrared image of 12-up Auer boat with $\pm 4^\circ\text{C}$ uniformity at 115°C across all parts.



Electro-pneumatic regulators control valve, fluid, and cooling/coax pressures. Pressure values are set in FmXP software and monitored directly from the computer screen. Gauges are removed from the front panel.

Rapid Response Heater System:

The Rapid Response Heater option with low-mass design minimizes processing time. The Controlled Process Heat (CpH) option provides software control of impingement air flow and temperature that eliminates operator interaction altogether. Programmable heat states allow high air flow for short pre-heat cycles and “step-down” or “no-heat” capability when a part is not present. The CpH option improves yield and provides “thermal footprint” efficiency by requiring less power.

Fids-on-the-Fly™:

The Fids-on-the-Fly option is up to 5.5 times faster than the traditional stop-and-capture method for locating fiducials and can increase UPH (units per hour) as much as 35 percent.

Programmable Fluid and Valve Pressure: Fluid and valve pressure values are set in the FmXP program, eliminating errors associated with manual adjustments during operation. Software-controlled pressure set points provide closed-loop process control and better traceability with log file capture. Complete recipes (including conveyor, heater and air pressure settings) are easily copied to other S-920N systems within the factory and around the world.

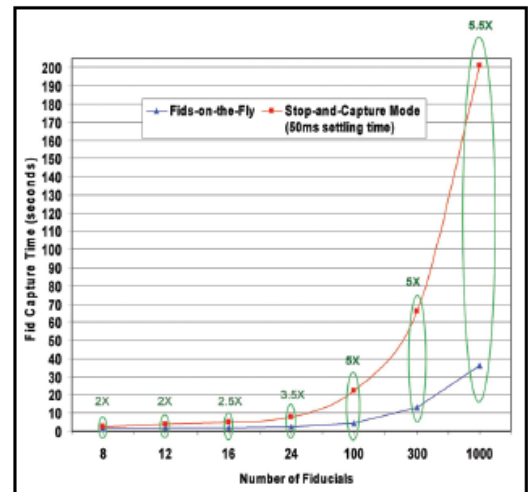

Tests were run on a variety of parts with a varied number of fiducials. Fids-on-the-Fly is 2 to 5.5 times faster than the stop-and capture method. The more fiducials required, the greater the time savings.



Innovative Designs and Customized Solutions

Nordson ASYMTEK designs and manufactures equipment that offers innovative dispensing solutions to customers worldwide. In addition to the standard product offerings, our experienced engineers can develop customized solutions to meet the unique demands of your environment. Nordson ASYMTEK has a solid history of developing customized solutions for fluid delivery, material handling, factory-specific lot tracking and control, vision and lighting systems, and software interface and control. Our goal is to improve your production throughput and yields, and ultimately, lower your cost of ownership.

Specifications: Spectrum™ S-920N Series

Motion System

X-Y placement accuracy:	±0.050 mm (0.002 in.), 3 sigma
Z accuracy:	±0.025 mm (0.001 in.), 3 sigma
X-Y repeatability:	±0.025 mm (0.001 in.), 3 sigma
X-Y acceleration:	1 g peak
X-Y velocity:	1 m/s peak (40 in./s)

Vision and Lighting

Camera resolution:	640 x 480 pixels
Field of view:	7.0 x 5.0 mm (0.28 x 0.20 in.)
Lighting:	Red/blue LED with 255 independent light levels for each color

Computer

Laptop with Windows® XP operating system

Software

Fluidmove® for Windows® XP

Fluid Delivery Method

Supports all Nordson ASYMTEK jets, piezo-activated valves, encoded auger pumps, spool, and pressure-time valves. An integration kit may be required.

Dispense Area (X-Y)

339 x 410 mm (13.3 x 16.1 in.)

Conveyor

Max. board/carrier length:	One station: 340 mm (13.4 in.) Three stations: 320 mm (12.6 in.)
Min. board/carrier length:	25 mm (1.0 in.)
Max. board/carrier width:	Single lane: 525 mm (20.7 in.) Dual lane: 228 mm (9.0 in.)
Min. board/carrier width ⁽¹⁾ :	34 mm (1.3 in.)
Max. board/carrier thickness:	12 mm (0.5 in.)
Max. overboard clearance:	30 mm (1.2 in.)
Underboard clearance:	2.75 mm (0.11 in.)
Transport height:	Conforms to SMEMA standard for conveyor height; height adjustable from 913-965 mm (35.9 - 38.0 in.) from floor to bottom of the part
Edge clearance:	6 mm (0.24 in.); 5 mm (0.20 in.) available by request
Maximum load capacity ⁽²⁾ :	2 kg (4.4 lbs.)
Operation modes:	Automatic (SMEMA), manual, pass-through
Belt types:	ESD O-ring, ESD high-temp 6-mm flat belt, ESD high-temp 4-mm flat belt

Facilities Requirements

System footprint:	Single heat station: 600 x 1321 mm (23.6 x 52.0 in.) Two heat stations: 850 x 1321 mm (33.5 x 52.0 in.) Three heat stations: 1100 x 1321 mm (43.3 x 52.0 in.)
Air supply:	689 kPa (6.8 atm, 100 psi)
Power (mains):	Power supply accommodates 200-240 VAC, 47-63 Hz single phase, 30 A
Ventilation ⁽³⁾ :	Downdraft or updraft
System weight ⁽⁴⁾ :	377 - 422 kg (830-930 lbs.)

(1) Contact factory regarding smaller boards/carriers.

(2) Total weight of all parts on conveyor at any one time. Contact factory regarding requirements for greater load capacity.

(3) For impingement heat applications, 100 cfm from the 6-in. exhaust port may be required. Contact the factory.

(4) System weight varies depending on configuration.

Standards Compliance

SEMI-S2; SEMI-S8; SMEMA; CE

Specifications: Spectrum™ S-920N Series

Dimensions are in millimeters

SIDE VIEW

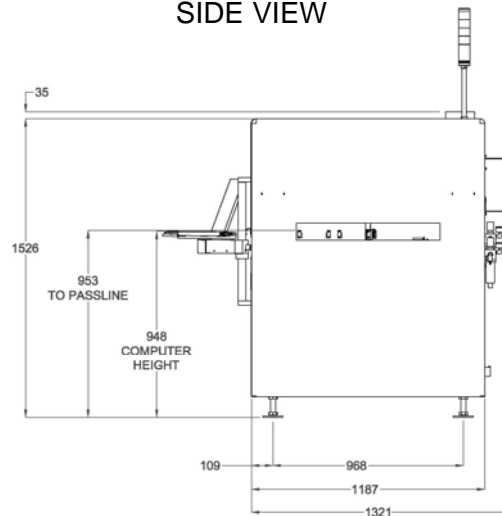

TOP VIEW

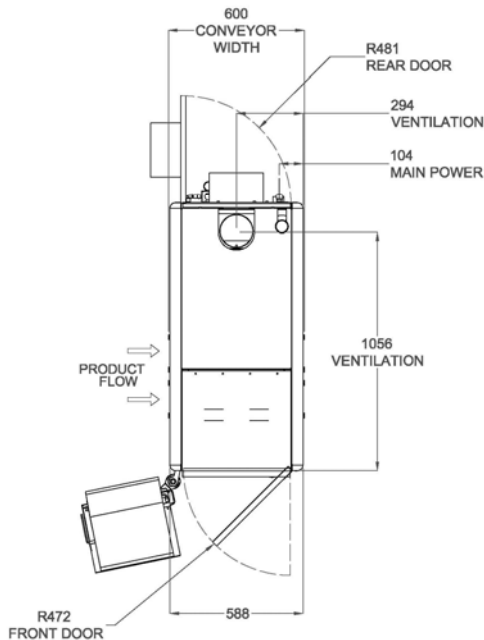

FRONT VIEW

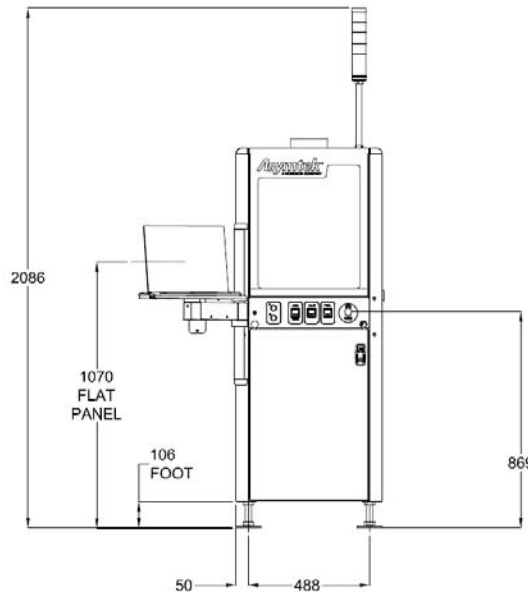

For more information,
speak with your local
representative or
contact your regional
office.

Nordsonasymtek.com

North America

Headquarters
Carlsbad, CA, USA
+1.760.431.1919
info@nordsonasymtek.com

China

Shanghai
+8621.3866.9166
info@asymtek.cn

Beijing
+8610. 8453.6388
info@asymtek.cn

Guangzhou
+8620.8554.0092
info@asymtek.cn

Europe

Maastricht, Netherlands
+31. 43.352.4466
cs.europe@asymtek.com

Japan

Tokyo
+81.3.5762.2801
Info-jp@nordsonasymtek.com

Korea

Seoul
+82.31.765.8337
info@nordsonasymtek.com

India

Chennai
+91. 44.4353.9024
info@nordsonasymtek.com

S.E. Asia/Australia

Singapore
+65.6796.9514
info@nordsonasymtek.com

Taiwan

+886.229.02.1860
info@nordsonasymtek.com

Nordson ASYMTEK

+1.760.431.1919 Phone

info@nordsonasymtek.com Email

2747 Loker Avenue West

Carlsbad, CA USA 92010-6603

www.nordsonasymtek.com

Published 2010-12

