

Viscosity Control System

Heated Recirculating Fluid Maintains Consistent Temperature of Coating Materials

Features and Benefits

- Provides process control for conformal coating to ensure consistent coverage
- Eliminates viscosity changes due to ambient temperature fluctuations
- Keeps fluid at a constant temperature, within $\pm 1\text{ }^{\circ}\text{C}$
- Protects material with an over-temperature alarm



Maintain consistent viscosity of your conformal coating fluids with the Viscosity Control System from Nordson ASYMTEK. A closed-loop, heated recirculating fluid circuit eliminates viscosity changes by precisely monitoring and controlling temperature. Additionally, emissions of Volatile Organic Compounds (VOCs) may be reduced, depending on the fluid properties.

Certain factors like ambient temperature changes and different material lots cause viscosity fluctuations. These fluctuations affect the performance and consistency of coating applied to printed circuit board assemblies.

By controlling the temperature of the conformal coating fluid circuit, viscosity fluctuations are reduced. With Nordson ASYMTEK's Viscosity Control system, fluid is heated and re-circulated while being monitored closely and maintained at set parameters. The system includes an over-temperature alarm as well as precise, closed-loop controls to maintain the temperature of the material at the applicator at $\pm 1\text{ }^{\circ}\text{C}$ ($\pm 1.8\text{ }^{\circ}\text{F}$).

Solvent usage may be reduced since the heat thins the coating material. As a result, higher film builds can be achieved in one pass because with less solvent there are more solids in the coating material.

For more advanced process control, the Viscosity Control System can be combined with the Nordson ASYMTEK Laser Fan Width Control option (Laser Fan Width Control automatically verifies fluid fan width). This combination allows users to perform process checks on the spot and as part of pre-programmed, regular equipment operation. Parameter settings are automatically adjusted quickly and efficiently, without operator intervention.

The Viscosity Control System is an option for the Select Coat SL-940E/SL-941E conformal coating systems, with the SC-204/SC-104 or SC-280C Film Coater applicators.

Specifications: Viscosity Control System

Typical Conditions

- Operating Flow: 0.38 to 0.76 l/min (1.0 to 0.2 gal/min).
- Operating Temperature: 40 to 50°C (104 to 122 °F).
- Operating Pressure: 138 to 276 kPa (20 to 40 PSI)

Note: System operating conditions depend on the fluid used.

Pump

- Max Air supply pressure 689 kPa (100 PSI)
- Operating pressure range 138 to 689 kPa (20- 100 PSI)
- Max Viscosity: 300 cPs.

Fluid Heater

- Voltage: 200-240 VAC
- Power: 500 Watts

Temperature Control

- Closed-loop, process temperature feedback, $\pm 1\text{ }^{\circ}\text{C}$ ($\pm 1.8\text{ }^{\circ}\text{F}$).
- Over-temperature alarm
- RTD temperature sensors

Certifications

- CE
- BASEEFA Approved Heater

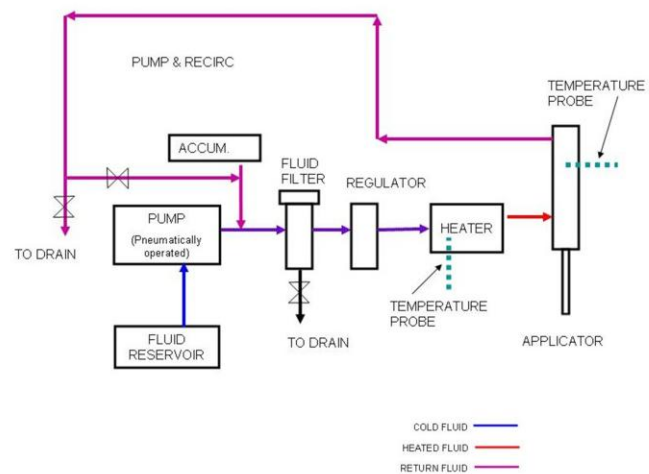

Theory of Operation

Fluid is continuously re-circulated in a heated circuit. Temperature sensors provide feedback to the system control, which manages temperature to ± 1 degree C. Pump siphons material from vented reservoir. Pump stroking pulsations are eliminated, ensuring a smooth and continuous fluid stream to the applicator. Safety is designed into the system by using components that meet the most stringent standards for use around volatile materials.

**For more information,
speak with your local
representative or
contact your regional
office.**

Nordsonasymtek.com

North America

Headquarters

Carlsbad, CA, USA

+1.760.431.1919

info@nordsonasymtek.com

China

Shanghai

+8621.3866.9166

info@asymtek.cn

Beijing

+8610. 8453.6388

info@asymtek.cn

Guangzhou

+8620.8554.0092

info@asymtek.cn

Europe

Maastricht, Netherlands

+31. 43.352.4466

cs.europe@asymtek.com

Japan

Tokyo

+81.3.5762.2801

Info-jp@nordsonasymtek.com

Korea

Seoul

+82.31.765.8337

info@nordsonasymtek.com

India

Chennai

+91. 44.4353.9024

info@nordsonasymtek.com

S.E. Asia/Australia

Singapore

+65.6796.9514

info@nordsonasymtek.com

Taiwan

+886.229.02.1860

info@nordsonasymtek.com

Nordson ASYMTEK

+1.760.431.1919 Phone

info@nordsonasymtek.com Email

2747 Loker Avenue West

Carlsbad, CA USA 92010-6603

www.nordsonasymtek.com

Revised 2011-07-08

