

SC-400 PreciseCoat™ Jet

Highly selective, precision jet coating

Features and Benefits

- **Highly selective jetting of coating materials**
- **Reaches locations not possible with other applicators**
- **Dot sizes to 1.5 mm (0.05 in.)**
- **Thinner film builds, to 15 µm**
- **Fast, up to 500 mm/sec (20 in./sec)**
- **Eliminates the need for masking**
- **Easy to disassemble and maintain**

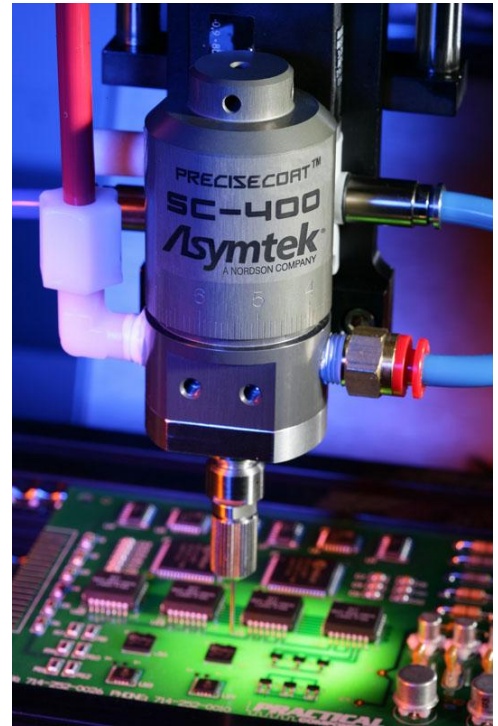

The SC-400 PreciseCoat™ Conformal Coating Jet is ideal for applying coating materials to highly selective areas. This solution is designed for coating small substrates or substrates with high-component density, and when there are tight tolerances between coated and uncoated areas.

The SC-400 jet reaches locations not accessible by other applicators, using a needle design with jetting action and fast pulse-width modulated control. Small volumes and better control of the material deliver line widths down to 1.5 mm (0.05 in.) wide. The need for masking is eliminated because the flow is so closely controlled. Film thicknesses of 15 micrometers are achievable when using solvent-based materials.

The SC-400 is available for use on the Select Coat SL-940E/SL-941E conformal coating system. A dual-valve configuration is available if your operation requires larger area coverage in addition to highly selective coating. This configuration combines the precision of the SC-400 jet with the fast, wide-area coverage of other applicators, like the SC-300 Swirl Coat or the SC-280N/SC-280C and SC-204/SC104 Film Coater applicators.

Additional benefits of the SC-400 jet make its use in production even more valuable. Multiple dot sizes can be delivered from the same applicator, yielding small volumes with good volume control. The SC-400 also allows for clearance above large components on a board, and its performance is not affected by warped substrates.

Specifications: SC-400 PreciseCoat™ Jet

General specifications

For use on Nordson ASYMTEK Select Coat® conformal coating systems

Operation: electrically controlled, air open, spring close

Valve pressure: 413 kPa (60 psi) minimum

Dimensions: *see diagram*

Weight: 500 gm (1.1 Lb)

Typical fluid dispense pressure: 21-345 kPa (3 and 50 psi)

Maximum/minimum needle length: 13 mm (0.5 inch)/
6 mm (0.25 inch)

Coating velocity: 125 – 500 mm/sec (5 - 20 in./sec)

Pulse Width Controller, integrated to coating platform

Pulse controlled by EasyCoat® for Windows XP software

Application parameters

Tested chemistries: acrylics, silicones, urethanes, UV-cure, water-based

Tested materials viscosity range: 0 to 850 cps

For higher viscosities, contact the factory.

Maximum deposition speed: 500 mm/sec

Dot size down to: 1.2 mm ± 0.06 mm

Option

Needle sensor: accurately positions the needle tip to provide closed-loop needle tip positioning

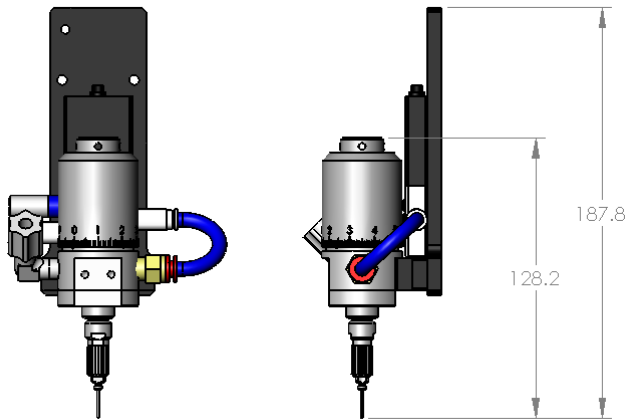
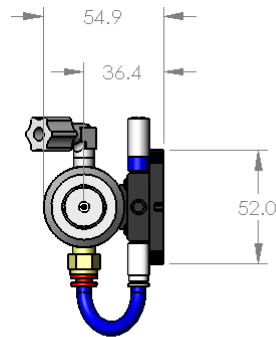

Nordson ASYMTEK

+1.760.431.1919 Phone

info@nordsonasymtek.com Email

2747 Loker Avenue West

Carlsbad, CA USA 92010-6603

www.nordsonasymtek.com

Content Published 2011-06-28

**For more information,
speak with your local
representative or
contact your regional
office.**

Nordsonasymtek.com

North America

Headquarters

Carlsbad, CA, USA

+1.760.431.1919

info@nordsonasymtek.com

China

Shanghai

+8621.3866.9166

info@asymtek.cn

Beijing

+8610. 8453.6388

info@asymtek.cn

Guangzhou

+8620.8554.0092

info@asymtek.cn

Europe

Maastricht, Netherlands

+31. 43.352.4466

cs.europe@asymtek.com

Japan

Tokyo

+81.3.5762.2801

Info-jp@nordsonasymtek.com

Korea

Seoul

+82.31.765.8337

info@nordsonasymtek.com

India

Chennai

+91. 44.4353.9024

info@nordsonasymtek.com

S.E. Asia/Australia

Singapore

+65.6796.9514

info@nordsonasymtek.com

Taiwan

+886.229.02.1860

info@nordsonasymtek.com

