

Pori Engineering Conference 2001

**Evaluation of Printed Circuit Board layout for Chip Scale Packages that Require Underfill and the Effect of Adjacent Passive Components**

**Steven J. Adamson**  
Asymtek  
Semiconductor Packaging and Assembly Product Manager  
[Sadamson@asymtek.com](mailto:Sadamson@asymtek.com)

**James J. Klocke**  
Asymtek  
European Business Development Manager  
[Jklocke@asymtek.com](mailto:Jklocke@asymtek.com)

**Lars Nielson**  
Scandinavian Business Development Manager  
[Lnielson@asymtek.com](mailto:Lnielson@asymtek.com)

**Abstract** – Chip Scale Packages have become a major new packaging format in recent years. One of the first industries to embrace this package format is the mobile communications sector. CSP's offer several advantages over leaded components, such as relatively small footprint, and can be processed with standard surface mount equipment. They have become so popular that CSP's are now used in almost all phone designs. Originally it was believed that chip scale packages would not require underfilling to meet reliability requirements. However most manufacturers have found it necessary to underfill these devices, to be able to meet users expectations for reliable phones. As the functionality of mobile phone handset increases, the complexity of the handset system PCB increases. This is pushing component densities to higher levels and the space between the CSP and the nearest components is has been drastically reduced in recent years. This now requires that strategies for underfilling CSP's include the effect of the adjacent passive components.

This paper will review board construction materials and placement of CSP and adjacent passive components and look at their impact on the underfill process. We will also discuss underfill of components under radio frequency shields.

## Introduction

In recent years, the authors have worked with a large number of companies manufacturing circuit boards for the portable electronics market. In some cases, underfilling of CSPs was considered unnecessary, and the design of system board was completed before it was realized that underfilling was required. After a product design is completed and prototypes produced, it is the wrong time to introduce an underfill process. Time scales in this phase of development are short and this can lead to non-optimized underfill process being implemented, which can lower throughput.

The goal of this paper is to review some of the factors that can impact the underfill process from a quality perspective and also throughput.

## CSP Definition

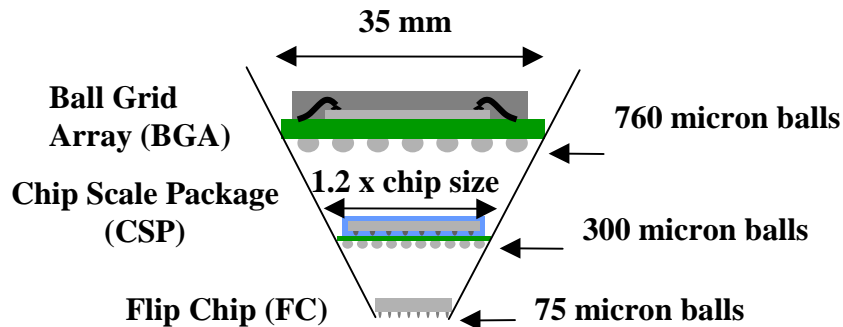

CSP devices have many different descriptive names and are sometimes called BGA's. For the purpose of this paper any packages that has an interposer board, are approximately 1.2 X the silicon chip size or have solder balls about 300 microns tall will be classed as CSP devices.

## Should A CSP be underfilled?

Many people have studied the reliability of area array packages such as BGA's, CSP's and Flip Chips. There is an abundance of information that suggests the reliability of these types of packages can be improved by underfilling the CSP devices. Typically the life of an assembly in thermal cycling tests is doubled. In addition many CSP system designs cannot meet drop test requirements unless they are underfilled.

With over 50 CSP designs [1] in the market each manufacturer has qualification data on their own package design. However the reliability of the product in the field is a combination of factors of which the package data is only part of the total system performance. The numbers of layers in the circuit board, how the components are positioned on the board and the system board enclosure around the electronics can significantly effect the overall reliability [2].

One very simple test employed by most system manufactures to simulate real life conditions is a drop the finished product (Cell Phone, PDA, etc) from one meter onto a hard concrete floor. This is repeated a number of times and either the prototype survives and continues into production or the design fails. In a number of cases the solder joints on CSP's have failed. At this point an underfill process is considered preferable to a board redesign..

In most cases underfill will improve reliability, however the Jet Propulsion Lab (JPL) in Pasadena has reported that flex-based CSP packages do not see an improvement in reliability when underfilled. [3]

## **Underfill Materials**

Underfill fluids redistribute the forces caused by differential thermal expansion, hold the solder bumps under isostatic compression, bond the CSP to the board to protect the solder joint from movement caused by mechanical transients. It also acts as an encapsulant to keep dirt and moisture from getting under the CSP.

Underfill fluids are dispensed onto the board after the CSP has been reflow soldered to the system board. The fluid is drawn under the CSP by capillary action and is then cured per the fluid formulator's specifications (typical cure temperatures are between 130° C to 160° C). Very fast curing underfills called "snap cures" react quickly when exposed to heat, curing from seconds to a few minutes. Underfill fluids that allow removal and replacement of the CSP are also available.

Thermal expansion of the underfill fluid is controlled by the addition of filler materials. Typically, a fluid is loaded 70 percent by weight with filler particles. Without filler, the rate of thermal expansion of the epoxy resin is 50 to 70 ppm/deg C. With the addition of filler materials, this can be reduced to 20 ppm/deg C. Underfill epoxies that match the thermal expansion rate of the solder bumps, i.e., 21ppm/deg C, appear to pass a higher number of thermal cycle tests than those with higher or lower CTE values.

An alternative class of materials called "no-flows" allows underfill fluid to be dispensed onto the system board prior to CSP placement. The fluid act as a flux, and with heat, is converted into an epoxy resin adhesive during the solder reflow step. This approach has the advantage of eliminating one of the ovens in the SMT line. With the CSP solder ball having to penetrate the fluid layer no-flow materials cannot contain fillers to lower the CTE value of the fluid. Filler particles could potentially inhibit a good solder joint from forming. When CSP's are placed onto the circuit board it does not have to be perfectly positioned. The self-aligning forces that are present when the solder paste melts can correct positional misplacements by up to 50% of the ball size. Some of the realignment capability is lost when a viscous fluid such as no-flow is present during the reflow step solder used.

CSP designs usually have an interposer layer. This can act as a chemical barrier between the IC and the adhesives. Encapsulants used with bare silicon die are normally specified to have less than 10ppm extractable chlorine. However with CSP's higher levels of

chlorine and other by-products can be tolerated because they are not in direct contact with the IC. This can allow the use of a more economical underfill material to be used as compared to flip chip devices [4]

## Solder Masks

Solder masks are used to protect the traces on the board from electrochemical corrosion and, in one class of circuit boards, to define the pad solder area. The underfill fluid must bond to the solder mask and to the underside of the die, solder bump, passivation and PCB. If either surface is not clean, the underfill may not be able to bond to the board or die.

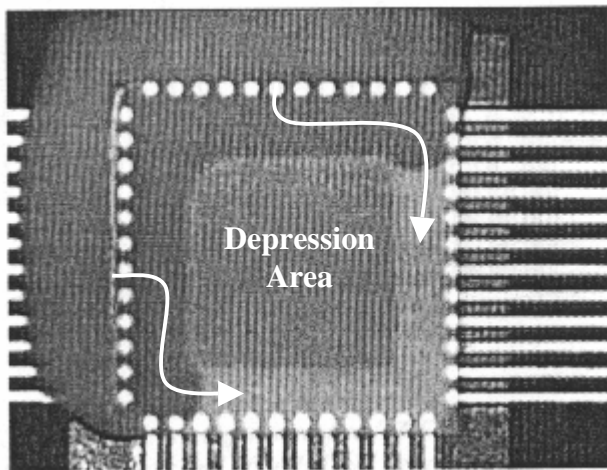

**Figure 2 Depression in solder mask changing flow of underfill [5]**

If the solder mask surface is uneven, it can channel the underfill fluid in unexpected ways. The picture to the left shows a quartz die with a peripheral bump pattern. An L-shaped underfill dispense on two sides (left and top) has started to flow under the die (see darker area). However, the solder mask layer has a square depression in the center. The underfill fluid has flowed around the depression rather than into it (see white arrows), due to stronger capillary forces between the die and solder mask, as compared to the depression area. Where underfill has not flowed, voids have resulted through air entrapment.

## Flux Residue

Flux residue can affect the ability of underfill epoxy to flow between small-pitch bumps and can weaken the bond between the die/interposer and system board surfaces. It is important that the amount of flux left after the reflow operation is minimized. In fact, some authors have shown significant thermal cycling life improvement when flux is thoroughly removed, even for SMT board assemblers using no-clean flux formulations.

SMT board assembly houses use solder paste with flux to tack components in place prior to conveying the boards into the reflow oven. Unfortunately, the elements in the flux that provide tackiness tend to leave residues on the board.

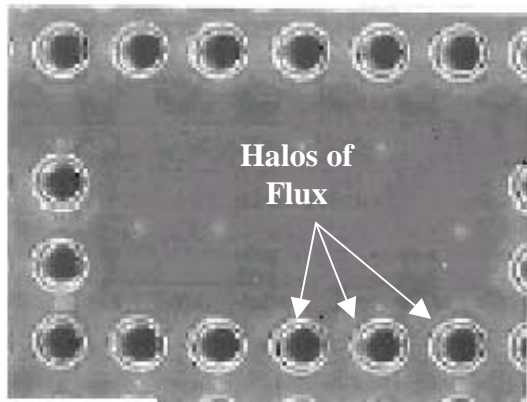

In the image to the right, solder bumps bonded to a system board are visible through the clear, quartz chip. As is readily apparent, a halo of flux has formed around the solder bumps. Underfill flow could be impeded, and the strength of the epoxy bond to chip and board weakened by the flux barrier

Figure 4, Flux residues around solder balls [6]

### Adjacent Passive Components

Adjacent passive components near a CSP can affect the throughput and quality of the underfill operation. All underfill materials will flow to some extent when heated, even no-flows. If a passive component touches the wetted area near a component under which underfill has been dispensed, it could rob the underfill from the active device, increasing the amount of underfill fluid required, or causing voids to develop under the active device. Capillary flow will not discriminate between a chip component and a passive one. While no detrimental effect has been reported on passives, which are in contact with the underfill. It does require a greater amount of material to be dispensed which in turn lowers throughput, and is wasteful of expensive underfill materials. It may also pose a rework problem if the passive component has to be replaced.

As designs get tighter between the die and passive components, it becomes increasingly difficult to insert a dispensing tip between the components. Designs of some cell phones have spacing as small as 0.6mm. With gaps this small, a 25-gauge needle would be required, with an outside diameter of 0.5mm. The maximum flow rate of fluid through a 25-gauge needle is less than 10 mg per second at 100 psi pressure in the pump. A 20-gauge needle, 10mm long with an OD of 0.9 mm, has a flow rate of 50 mg per second. Hence, dispensing time is considerably impacted by the

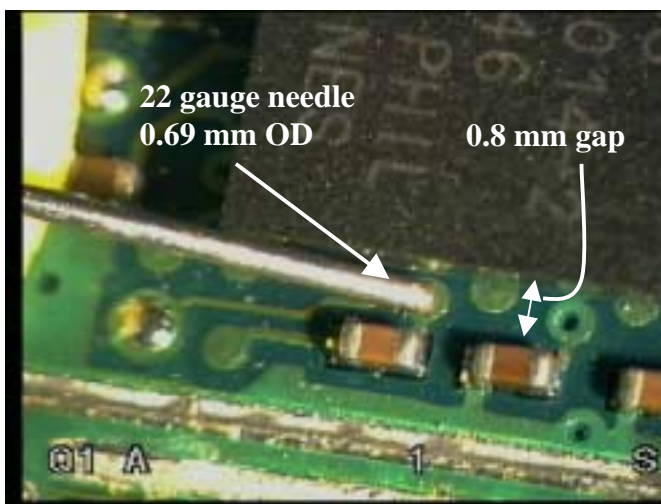
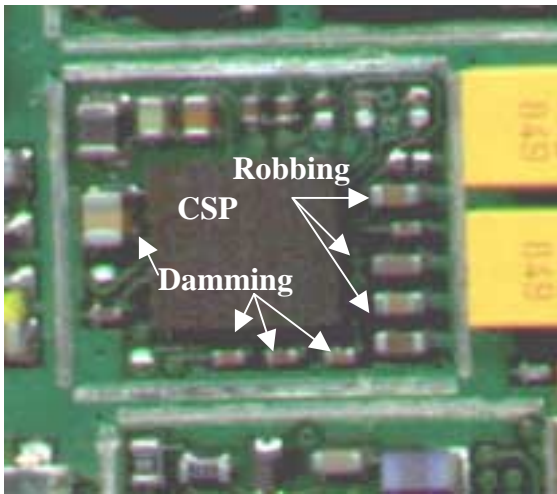

Figure 5, Needle in gap between CSP and chip components

gap between the chip and passive component.



The orientation of the passive component can affect how fluid is drawn away from chip components. Passive components that run parallel with the edge of the CSP or flip chip tend to have a dam-type effect, containing the fluid. The passives that are oriented 90° to the CSP edge tends to pull underfill fluid away from the CSP.

Figure 6, Chip component orientation around CSP

In cases where passive components have to be placed close to the CSP or flip chip, it may

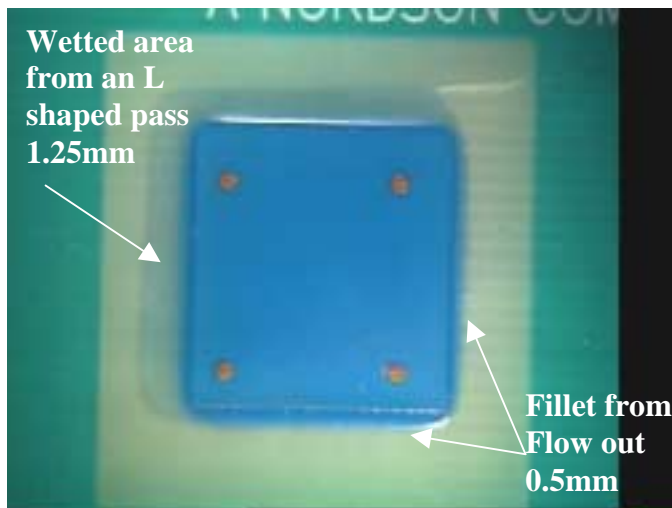

be possible to apply fluid to one or two sides of the device opposite to the component side. The witness mark or wetted area on the side to which the fluid is applied is larger than the natural fillet form on the opposite side of the chip. In the image to the left, it can be clearly seen that if a seal pass is not required, components could be placed much closer to the side where the fluid has formed a natural fillet, as opposed to the sides where the fluid was applied.

Figure 7, Wetted area v fluid fillet size

An alternative method is to place dots of underfill fluid on the sides or corners of the device being underfilled. However, careful selection of these sites for dispensing is required. Otherwise, fluid can trap air, creating voids, as the underfill fluid front, flows around the periphery of the device.

## Radio Frequency Shielding

Cell phones and other portable devices that use radio frequencies to communicate have RF shields covering the active CSP's, to limit unwanted emissions. The RF shields are assembled similar to other surface mount components. Solder paste is screened onto the board and the shield is placed

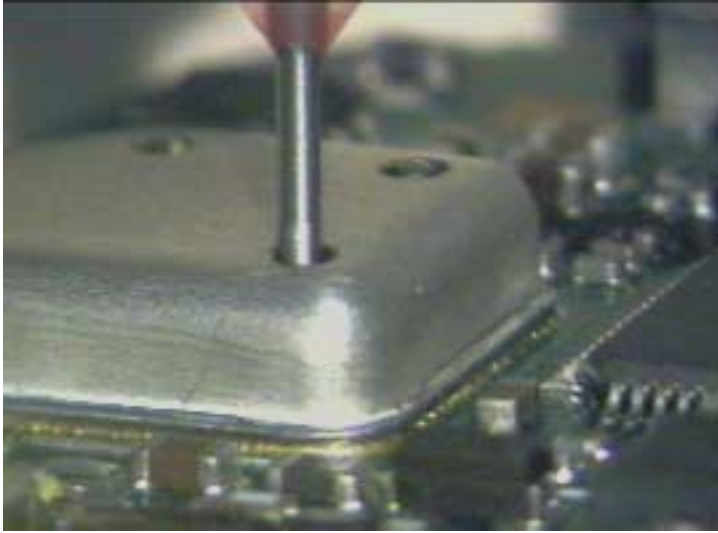

Figure 8, Underfilling a CSP under a shield

into the paste. The board is passed through a reflow oven to attach all the components in one operation, including the RF shields. Unfortunately the CSP devices still require underfill. In this case, the only choice is to either use a no-flow underfill prior to component placement or provide underfill through holes in the shield. This not desirable but depending on the frequency of operation small holes in the shield can be

tolerated. In this case, the size of the hole will limit the size of the

needle that can be used. Small holes will limit the diameter of the needle, and the flow rate through the needle is reduced. The smaller the needle, the lower the UPH in production.

## Connectors

In most cell phones designs, a connector is used to attach the phone accessories. These connectors have fine pitch leads which draw in fluid. If the connector leads are adjacent to a device to be underfilled, care must be taken to avoid contact between the leads of the connector and the wetted dispense area. The leads provide a capillary path for the fluid to

flow into the connector.

Once fluid has been drawn into the connector it would have to be replaced. A fluid dam of high viscosity epoxy can be used to contain the underfill fluid. Allowing tighter placement than would normally be acceptable. Both the dam and the underfill are cured at the same time.

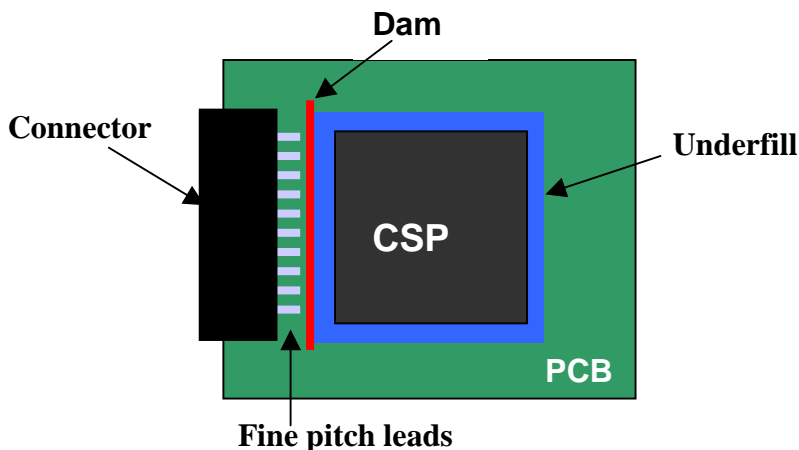

## Summary

Many factors can influence the design of a PCB where CSP or flip chip packages will be underfilled. These can range from component layout design to the basic properties of the underfill fluid. The selection of solder mask materials and the surface finish can effect the flow properties of the fluids. Components adjacent to the device being underfilled need to be identified, allowing underfilling of die while precluding adjacent components from robbing fluid. Underfilling through holes in a shield can complicate the process even further.

Designing the layout of a PCB with CSP and flip chip components to be underfilled requires close collaboration between the design engineers and the production department. If passive components are placed too close to the active component, this could slow the assembly process significantly.

The underfill process is simple, and the equipment available today for dispensing works consistently 24 hours per day, 7 days per week. Provided the design of the system board takes into consideration the factors discussed in this paper, the assembly operation should be able to maximize throughput for a high-yielding process.

### References:

[1] Chips Scale Package

John Lau, S.W. Ricky Lee, McGraw-Hill, ISBN 0-07-038304-9

[2] H. Juso, Y. Yamaji, T. Kimura, K. Fuhita and M. Kada, " Board level Reliability of CSP" Proceedings of the 48<sup>th</sup> ECTC, Bellevue, Wash., may 1998, pp 525-531

[3] Reza Ghaffarian, Impact of CSP Assembly Underfill on Reliability, P-AD2 Paper 3, Apex, Process Exhibition and Conference, March 16-18, 2000, Long Beach, CA

[4] Maurice Edwards, Modification of Flip Chip Underfill Encapsulants for Use as a CSP and BGA Underfill, HDI EXPO, September 25 –27, 2000, Phoenix Civic Plaza, AZ

[5] Jing QI and R Wayne Johnson, Auburn University,  
IMAPS, Volume 22, November 3, Third Quarter 1999, page 270 - 278  
Johnson

[6] Jason P. Goodelle, Jeffery J. Gilbert, and Ronald E. Fanucci,  
Evaluating Underfill Materials for High Reliability Applications  
Session 9, Underfill Materials, ECTC Conference, May 22<sup>nd</sup>, Las Vegas, NV